

User Manual

Telephone Line Simulator



Contents

IMPORTANT SAFETY INSTRUCTIONS.....	iii
COMPLIANCE INFORMATION	iv
Chapter 1: Overview.....	1
Table 1 Front Panel Switch Functions	3
Table 2 LED Indicators.....	3
Chapter 2: Feature Applications	4
Uses for Off-Hook Modes	5
Uses for Hunt Mode	6
Chapter 3: Installation.....	7
Demonstrating Equipment	7
Restoring Defaults.....	8
Testing Installations	8
Figure 1 Telephone Line Simulator (TLS-4A).....	9
Chapter 4: Operation.....	10
Setting up a conference call	10
Transferring a call	10
Using the Audio Port	12
Making a Tape on a Tape Recorder	12
Generating a Tape from a Telephone.....	13
Figure 2 Audio Port Connector Cable.....	13
Playing a Message from the Audio Port	14
End of Message Tape Sequence	16
Figure 3 End of Message Tape Sequence.....	16
Chapter 5: Testing Equipment and Installations	17
Testing Key Systems or PBX Lines.....	17
Manual Continuous Ring Test	17
Line Wiring/Basic Function Test	17
Nonstandard Ring Cadence Test	18

Dial Pad Check	18
Telephone Handset Check	19
Call Progress Tone Test	19
Test Numbers.....	19
Figure 4 Clip Cable Connectors (Used with Terminal Block)	21
Figure 5 Key System Test Connections	21
Chapter 6: Programming	22
Types of Commands.....	22
Command Format	23
Command Dictionary	24
Systemwide Commands.....	28
Per-line Commands	32
Chapter 7: Warranty, Troubleshooting, and Return	41
Warranty Information	41
Troubleshooting	41
Figure 6 Fuse Holder Location.....	41
Return Procedures.....	42
Technical Support	43
Chapter 8: Electrical Specifications	44
Chapter 9: Ordering Information	46
Appendix A: Glossary.....	47
Appendix B: Programming Quick Reference	48
Index	51

IMPORTANT SAFETY INSTRUCTIONS

When using your telephone equipment, basic safety precautions should always be followed to reduce the risk of fire, electric shock, and injury to persons, including the following:

1. Read and understand all instructions.
2. Follow all warnings and instructions marked on the product.
3. Unplug this product from the wall outlet before cleaning. Do not use liquid cleaners or aerosol cleaners. Use a damp cloth for cleaning.
4. Do not use this product near water, for example, near a bath tub, wash bowl, kitchen sink, or laundry tub, in a wet basement, or near a swimming pool.
5. Do not place this product on an unstable cart, stand, or table. The product may fall, causing serious damage to the product.
6. Slots and openings in the cabinet and the back or bottom are provided for ventilation. To protect it from overheating, these openings must not be blocked or covered. The openings should never be blocked by placing the product on a bed, sofa, rug, or other similar surface. This product should never be placed near or over a radiator or heat register. This product should not be placed in a built-in installation unless proper ventilation is provided.
7. This product should be operated only from the type of power source indicated on the marking label. If you are not sure of the type of power supply to your home, consult your dealer or local power company.
8. Do not allow anything to rest on the power cord. Do not locate this product where the cord will be abused by persons walking on it.
9. Do not overload wall outlets and extension cords as this can result in fire or electric shock.
10. Never push objects of any kind into this product through cabinet slots as they may touch dangerous voltage points or short out parts that could result in fire or electric shock. Never spill liquid of any kind on the product.
11. To reduce the risk of electric shock, do not disassemble this product, but take it to a qualified serviceman when some service or repair work is required. Opening or removing covers may expose you to dangerous voltages or other risks. Incorrect reassembly can cause electric shock when the appliance is subsequently used.
12. Unplug this product from the wall outlet and refer servicing to qualified service personnel under the following conditions:
 - A. When the power supply cord or plug is damaged or frayed.
 - B. If liquid has been spilled into the product.
 - C. If the product has been exposed to rain or water.
 - D. If the product does not operate normally by following the operating instructions. Adjust only those controls that are covered by the operating instructions, because improper adjustment of other controls may result in damage and will often require extensive work by a qualified technician to restore the product to normal operation.
 - E. If the product has been dropped or the cabinet has been damaged.
 - F. If the product exhibits a distinct change in performance.

COMPLIANCE INFORMATION

Part 15 Class A Notice: This equipment has been tested and found to comply with the limits for a Class A digital device, pursuant to Part 15 of the FCC Rules. These limits are designed to provide reasonable protection against harmful interference in a commercial environment. This equipment generates, uses, and can radiate radio frequency energy and, if not installed and used in accordance with the instruction manual, may cause harmful interference to radio communications. Operation of this equipment in a residential area is likely to cause harmful interference, in which case the user will be required to correct the interference at his own expense.

Chapter 1: Overview

This manual describes the Telephone Line Simulator-4A which tests telephones and other telecommunications devices.

The TLS-4A Telephone Line Simulator offers a convenient means for setting up temporary “telephone lines” to demonstrate or test equipment where actual central office lines are not easily available. The TLS-4A provides four simulated lines, two “talk paths” or connections, and an audio interface port, making it a versatile device for a variety of applications including:

- Demonstrating or testing telecommunications devices such as telephone sets, fax machines, and modems. Two simultaneous, independent conversations can be set up over the four lines.
- Playing prerecorded presentations over a line when the telephone handset is lifted (for example, at trade show or museum displays)
- As a teaching aid with the audio port configured to allow monitoring and/or recording of a telephone conversation (for example, when teaching children to use “9-1-1”)
- Testing telephone or key system installations
- Limited testing of loop start PBX installations

Static Protection

Use standard precautions in discharging electrostatic buildup before operating this equipment or any other electrical equipment.

Features

- Programmable operations:
 - Two phone numbers for each line
 - Forced disconnect
 - Hot line (“ringdown”) number
 - Ring cadence 1-3 rings
 - Hunt groups
 - Immediate or dial access to audio port
 - Tone or recorded message when an invalid number is dialed
 - Monitor mode (allows recording phone calls for training use)
 - PBX-like operations: call transfer, add on, hook flash
 - Timing adjustments
 - Second dial tone simulates outside line access
 - Tone following disconnect
- Provides four lines and two connections
- Portability and quick, convenient setup

- Accepts tone and rotary input
- Ringing voltage source with short circuit protection
- AC powered (battery not required)
- Non-volatile memory (battery not required)
- Generates precise call progress tones
- Ground reference jack
- -48 V ground referenced line voltage
- Audio port

Calling Operations

The TLS-4A provides dial tone to a line when the telephone handset is lifted. When a rotary dialed or tone digit is detected, dial tone stops. If a number is misdialed, reorder tone (or another programmable tone) is sent to the caller or the caller is connected to the audio port (see command 31 on page 34).

When a valid number has been dialed, ringback tone is sent to the caller and the called line rings. When the called line answers, ringback tone stops and a connection is established between the parties. When either party goes on-hook, the off-hook line receives about 2 seconds (default) of silence, followed by dial tone, or Cutoff on Disconnect. See command 38, Forced Disconnect, on page 38 for more information.

Physical Description

The TLS-4A is a portable unit weighing just over 4 pounds. A detachable power cord is supplied with the TLS-4A. As shown in Figure 1, the front panel provides: four modular RJ-11 jacks for connection of the equipment to be demonstrated or tested, a multifunction switch (see Table 1), and the indicators listed in Table 2. A 5-pin DIN jack on the back panel enables sending or receiving audio to/from any line. The audio is turned on or off by a software-driven relay. A fused, modular AC power jack and an optional chassis ground reference point are also located on the back of the unit.

For key telephone and PBX line testing, a modular/alligator clip cable is available as an ordering option (Figure 4) to enable connection of lines from a terminal block to the TLS-4A.

Position	Label	Functions
Top	MAN/RING	<p>Momentary contact position with multiple uses:</p> <p>(1) Restore defaults: Within 1 second of turning power ON, press and hold for 5 seconds to clear all programming and restore default options. Release after the POWER light turns ON.</p> <p><i>Caution: Do not use the MAN/RING feature at power up.</i></p> <p>(2) Manual ring: With Line 1 on-hook, press and hold to ring Line 1. Ringing continues until the switch is released.</p> <p>(3) Programming mode: With Line 1 off-hook, and all other lines on-hook, press and hold for 1 second to place the TLS-4A in programming mode.</p>
Center	ON	POWER ON (Press and release the top portion of the switch.)
Bottom	OFF	POWER OFF

LED Operation

The table below explains how the LEDs on the TLS-4A front panel operate and what the different blinking patterns indicate.

Indicator	State	Description
Line 1—Line 4	ON	Line is off-hook
	Flashing (fast on/off)	Line is ringing
	Blinking (slow on/off)	Programming mode: Line is selected for programming
	Half brightness	During dialing, indicates that a valid DTMF digit is present
PWR	Slow blinking	Power is present and processor is running normally
AUDIO	ON	Audio control lead is on

Chapter 2: Feature Applications

The TLS-4A offers an array of programmable features to suit a variety of applications.

Two Numbers Per Line

Each of the four lines can be assigned two telephone numbers, each number a maximum of 16 digits long.

This feature may be used to program one number with a standard ring cadence and the other with a nonstandard ring cadence. Another use might be to assign all four lines the same second number in order to setup a hunt group or ring all telephones with one call.

Ring cadences on the second phone number can be varied, confirmation and error tones disabled, and audio port access blocked from certain lines. Hot line (“ringdown”) numbers and hunt groups can be setup. These and other programmable features are described in Chapter 6. The unit is programmed by connecting a tone (DTMF) telephone to the unit and entering digit codes.

Audio Port

The audio port can be configured for immediate or dial access or as a monitor, may allow single or multiple lines to be connected simultaneously, and can vary the method of turning off the recorded message.

Distinctive Ringing

The ring cycle timing for the first number on each line is always the standard 2 seconds on, 4 seconds off. The ring cycle timing for the second number on each line is programmable. (See Programming.) This gives the ability for each line to have two different ring cycles by simply dialing the two different numbers associated with that line.

Group Ringing

It is possible to have a group of phones that can be rung simultaneously, yet still be able to ring them individually. By programming different first numbers for each line, but the same second number for each line, and having the hunt mode set to “ring all”, dialing the first numbers will ring an individual phone (with standard ringing), and dialing the second number will ring all the phones simultaneously (with distinctive ringing).

Invalid Number

You can program how the TLS-4A will respond to an invalid number. It can respond with busy tone, reorder tone, ringback tone, silence, or it can connect the calling line to the audio port. Regardless of the response you select, there will be a delay before the response is activated.

If an invalid number beginning with any number other than “1” is dialed, the TLS-4A will respond after 7 digits have been entered or after 8 seconds have passed.

-or-

If an invalid number beginning with “1” is dialed, the TLS-4A will simulate the telephone network’s delay by waiting until 11 digits have been entered or 8 seconds have passed since the last digit was entered.

If you program the TLS-4A to connect invalid numbers to the audio port, calls arriving when the audio port is already in use will get busy tone.

Uses for Off-Hook Modes

A detailed explanation of command 32, Off-Hook Modes, is provided in Chapter 6.

Standard Mode

This provides normal dialing features.

Hot Line Mode

Hot line mode is normally used to ring one phone automatically the moment you pick up another. To use this feature, program the off-hook mode for the line from which you will make the call as “hot line” (see Chapter 6 for details). Program the “revert/hotline” number to the first or second number of the line you wish to ring. When you go off-hook on the originating line, ringback will be heard, and the destination line will ring.

Silent Mode

This mode can be used to provide silence when you go off-hook. To use this feature, program the off-hook mode for “silence”. Any or all of the lines can be used in this way.

Uses for Hunt Mode

Hunt Mode, command 35, can be used to Simulate Trunk Groups/Telethons. Please see Chapter 6 for a detailed explanation of this command.

Ring First/Ring Next/Ring All

When Hunt mode is set to “ring first available”, “ring all”, or “ring next” with multiple lines set to the same phone number, it simulates a group of lines with a single pilot number (like the trunks into a PBX system). “Ring first available” will always ring the lowest non-busy line. This will cause the lowest line to receive the most calls. “Ring next” will ring the next non-busy line in sequence above the last one to have rung. “Ring all” will ring all the lines until one goes off-hook.

Chapter 3: Installation



Caution: The TLS-4A generates up to 95 VAC ringing voltage. *Be sure the TLS-4A power switch is off before handling cord ends.*

Step 1: Connect power cord

- Connect the AC power cord to the TLS-4A and to the wall receptacle.

Step 2: Connect telephones

- Plug up to four telephones or other telecommunications devices into the line jacks on the TLS-4A front panel.

Step 3: Turn on power

- Turn the TLS-4A power switch on.

Step 4: Chassis ground (optional)

- If a chassis ground is required, plug a 0.080-inch diameter pin probe into the chassis ground reference Jack on the back panel. The location is shown in Figure 1.

Step 5: Audio port (optional)

- To generate or play a recorded tape message, refer to Generating a Tape, later in this chapter.

Demonstrating Equipment

Caution: The TLS-4A generates 95 V ringing voltage. *Be sure the TLS-4A power switch is off before handling any cord ends.*

To demonstrate equipment, do the following:

- With two devices connected to the TLS-4A, place a call from one device to the other by dialing the number of the other device. The default numbers for Lines 1 through 4 are 101 through 104, respectively.

Note: If you wish, you can change the phone number for any line to any digit string from 1 through 16 digits by reprogramming the line as described in Chapter 6.)

- When the other line rings, answer the call. A connection should be established and equipment features can be demonstrated.
- When the call is completed, hang up both devices.

Restoring Defaults

If your TLS-4A does not operate as expected, a previous user's feature programming may be the cause. To restore the unit to default operating conditions:

- Be sure all phones are on-hook, then toggle the front panel switch to OFF, then to MAN/RING and hold *until the POWER LED comes on*, then release.
- Read the previous section (Demonstrating Equipment) to place a call from any line to any other.

-or-

- Enter ****99##** to access programming mode and enter: ***00#0#*00#0#**

Testing Installations

The procedures below assume that the TLS default settings have *not* been changed. If you have trouble with any of the following procedures, the TLS may have been programmed already.

Testing key system and PBX lines

- Connect the TLS-4A lines to Tip and Ring of PBX or key system central office loop start trunks (E&M, DID, or ground start trunks *cannot* be tested with the TLS-4A).
- If a ground reference is required, connect a 0.080-inch diameter pin tip probe to the chassis ground reference jack on the unit back panel (Figure 1).

Figure 4 shows the pin connections for the alligator clip cables used to connect TLS-4A lines to a terminal block (*cables ordered separately*). Please see Figure 5 in Chapter 6 for a generalized diagram of key system test connections.

Caution: When ringing is applied, the Ring lead of the modular jacks carries up to 95 VAC referenced to ground (alternating polarity). *Be sure the TLS-4A power switch is off before handling any cord ends.*

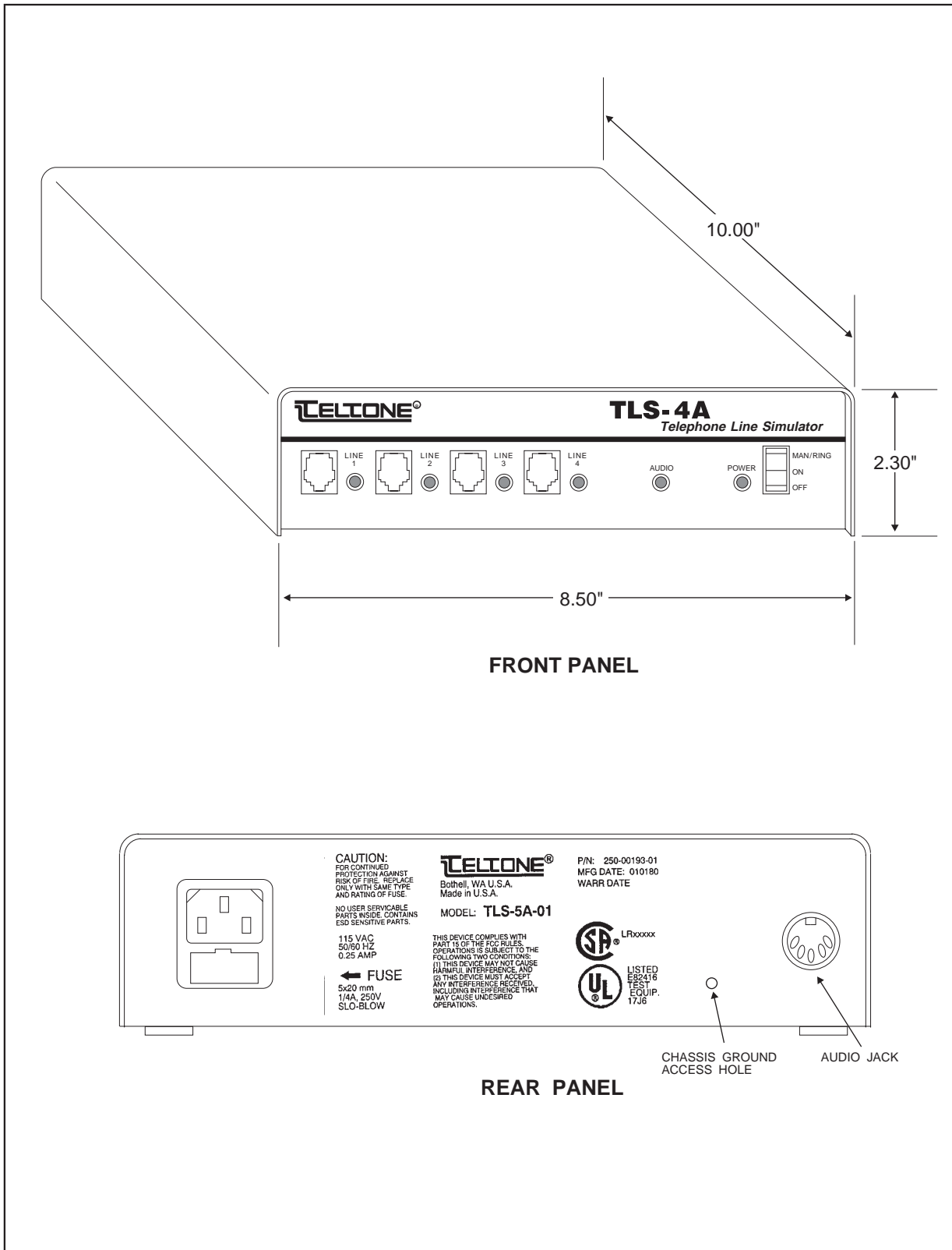

Figure 1 Telephone Line Simulator (TLS-4A)

Chapter 4: Operation

Setting up a conference call:

Flash detection (command 34) must be enabled (default) in order to set up a conference call or transfer a call by executing the steps below. If you are unable to add a third party or transfer a call, enable flash detection as described on the next page. If flash detection is disabled, a flash will be treated as a disconnect.

Step 1: Connect devices

- Connect devices to at least three TLS-4A lines.

Step 2: Establish call

- Establish a call between two parties as described in Demonstrating Equipment on page 7.

Step 3: Flash the line

- Press the FLASH button (if the telephone has one) or momentarily press the button in the telephone handset cradle.

Step 4: Dial third number

- Dial a third number.

Step 5: Flash the line

- After the third party answers, send a flash to reconnect the second party.
- With three parties connected, you can add a fourth party by repeating Steps 3 through 5.

Transferring a call:

Step 1: Establish call

- With devices connected to three or more TLS-4A lines, establish a call between two parties.

Step 2: Flash the line

- Execute a flash as described above, then dial the third party.

Step 3: Hang up on answer

- After the third party answers, hang up.

To use the audio port:

- See the Using the Audio Port section.

To test equipment functioning:

- See Chapter 5.

To enable flash detection:

This procedure is not necessary unless flash detection was disabled by a previous user.

Step 1: Access Program Mode On Line 1

- Lift the handset. Press and hold the switch in the MAN/RING position until the Line 1 light blinks and confirmation tone (three beeps) is heard.

Step 2: Enter command

- With a telephone plugged into Line 1, enter the following:

***34#1#**

- Listen for three beeps indicating that the command is accepted. If you do not hear the beeps, refer to Chapter 6, Programming.

Step 3: Hang up

- Hang up the telephone.

On Lines 2, 3, or 4:**Step 1: Access Program Mode**

- Lines 2, 3, and 4 must be on-hook. Lift the handset at the telephone connected to Line 1.
- Press and hold the switch in the MAN/RING position until the Line 1 light blinks and you hear three beeps.

Step 2: Select line and enable flash detection

- Enter the command *02#, *03#, or *04#, as appropriate. The associated line light will begin blinking.
- Enter: *34#1#
- Listen for the three confirmation beeps. If you do not hear the beeps, see the programming instructions.
- Hang up the telephone.

Using the Audio Port

The section below tells you how to generate a tape recorded message and play the message over a TLS-4A line. You can record messages in either of two ways:

- on the tape recorder (use of an external microphone is recommended)
- or-
- using a telephone.

Tape Recorders

Please use tape recorders *without* automatic or dynamic level control because automatic level control can amplify background noise, ruining the silent period at the end of the message.

- Notes:** (1) Always use a new tape or one that has been erased because the TLS-4A looks for three seconds of silence followed by a sound for an “end-of-message” indication. See “End of Message Tape Sequence” at the end of this section.
- (2) Be sure the tape used is the correct bias type for the recorder.

Making a Tape on a Tape Recorder

The commands used in the following steps are explained in Chapter 6: Programming.

Step 1: Connect microphone

- Connect a microphone to the cassette recorder/player.

Step 2: Turn on player

- Turn on the cassette recorder/player and press the RECORD button.

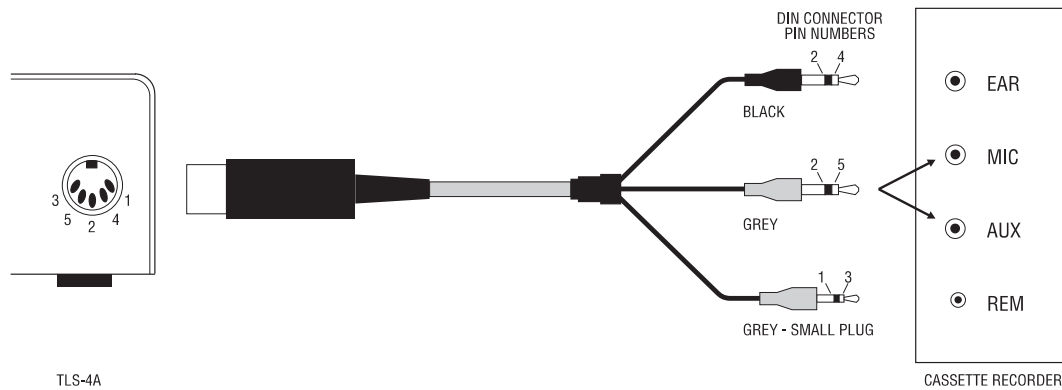

Figure 2 Audio Port Connector Cable

Step 3: Speak message

- Speak the message, taking care that you do not pause for more than three seconds before the end of the message.

Step 4: End message

- At the end of the message, pause for at least 3 seconds, then speak one more word. If you wish to record the message more than once, or make a series of recordings, pause briefly before beginning the next message.

Generating a Tape from a Telephone

Step 1: Program audio port

- With a tone (DTMF) telephone connected to Line 1, lift the handset and press the MAN/RING switch position until the Line 1 light blinks and confirmation tone (three beeps) is heard.
- Enter: ***33#1#** (This enables Audio Port Permission for Line 1. You will hear three beeps if the command is accepted.)
- Enter: ***05#1#0#0#** (This configures the audio port for immediate access, single user, and disconnect when the handset goes on-hook.)
- Hang up.

Step 2: Connect player

- Connect a cassette recorder/player to the TLS-4A.
- Using a standard cassette player cable (*not supplied*) with a 5-pin DIN connector at one end and three connectors at the other (refer to Figure 2).
- Plug the 5-pin DIN connector into the TLS-4A AUDIO port.
- Plug the connectors at the other end of the cable to the cassette recorder/player as follows:
 - Connect the small gray cable (see Note, below) to the REMOTE jack.
 - Connect the large gray (see Note, below) cable to AUX. (If the machine has no AUX jack, or the recording is unsatisfactory, connect this cable to MIC.)
- Leave the black cable unconnected for recording (it should be connected for playback).

Note: Cable colors will vary depending on manufacturer.

Step 3: Turn on player

- Turn on the cassette recorder/player and press the RECORD button.

Step 4: Lift handset

- Lift the Line 1 telephone handset. The AUDIO light turns on.

Step 5: Speak message

- Speak the message, taking care that you do not pause for more than three seconds before the end of the message.

Step 6: End message

- At the end of the message, pause for at least 3 seconds, then press any digit key (0-9) or speak a word. If you wish to record the message more than once, or make a series of recordings, pause briefly before beginning the next message.

Playing a Message from the Audio Port

Follow these instructions to play a message through the TLS-4A audio port to a line. This is the default mode, *Step 1 is only necessary if you have changed the default settings.*

Step 1: Program audio port

Program the TLS-4A audio port as follows:

- With a tone (DTMF) telephone connected to Line 1, lift the handset and press the MAN/RING switch position until the Line 1 light blinks and you hear a confirmation tone (three beeps).
- To enable Audio Port Permission for Line 1, enter: ***33#1#**
- Listen for three beeps if the command is accepted.
- To configure the audio port for immediate access, single user, and disconnect at end-of-message, enter: ***05#3#0#1#**
- Listen for three beeps and hang up.

Step 2: Connect Audio Source

- Using a standard cassette player cable (not supplied) with a 5-pin DIN connector at one end and three connectors at the other (refer to Figure 2).
- Plug 5-pin DIN connector into the TLS-4A Audio port.
- Plug the connectors at the other end of the cable to the audio source as follows:
 - Connect the small gray cable to the control jack.
 - Connect the black cable to the audio output from the source.
 - (The large gray cable is not used.)

Note: Cable colors will vary depending on manufacturer. See Figure 2.

- Apply power and turn on the audio source (e.g., tape recorder).

Step 3: Play message

- Lift the Line 1 telephone handset. The message will begin playing. At the end of the message, the TLS-4A will turn off the cassette player.
- Hang up.
- Each time the telephone handset is lifted, the message will be repeated (continuous loop tape) or the next message will be played (normal tape).

To cancel immediate access, lift the handset on Line 1 and press the MAN/RING switch position until the Line 1 light blinks. Then enter the following:

***05#2##** (This specifies dial access, single user, disconnect at on-hook. Hang up.)

End of Message Tape Sequence

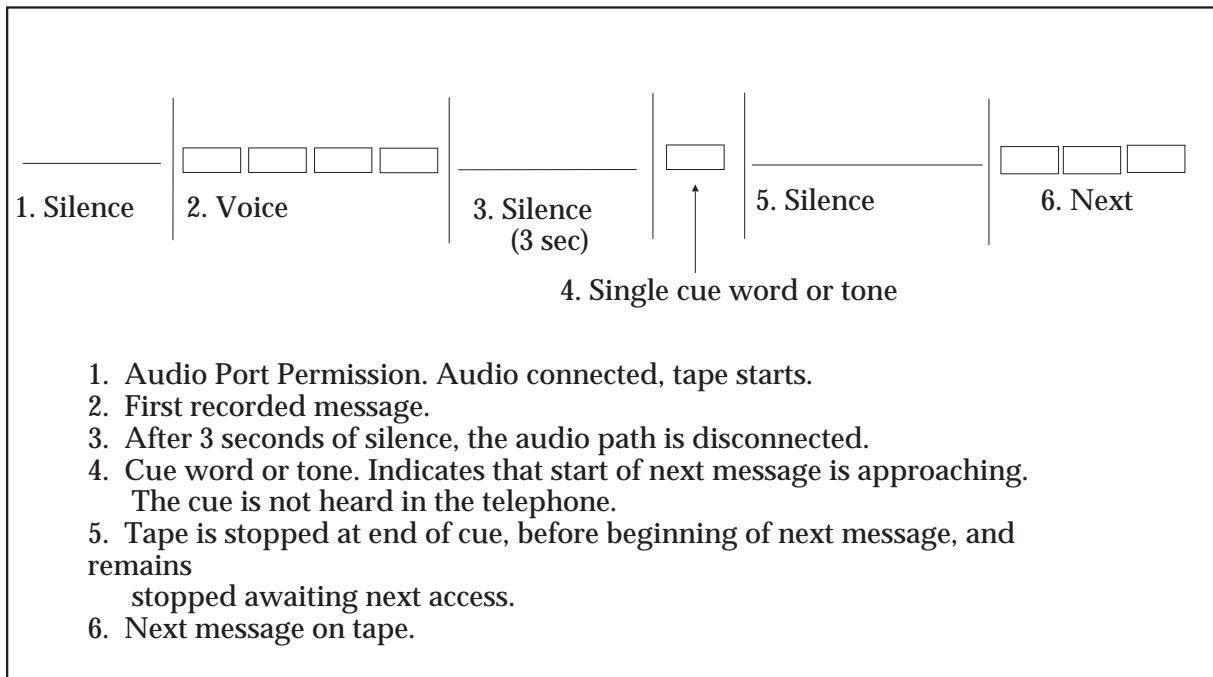

Figure 3 End of Message Tape Sequence

An “end of message” tape sequence is a method for automatically turning off a tape recorder (connected to the audio port) at the end of a message, and positioning the tape for the start of the next message. This allows a single message to be played each time the audio port is accessed.

Refer to Figure 3. The sequence consists of a 3-second (minimum) silent period followed by a single short word or tone. When the TLS-4A detects 3 seconds of silence, it removes the audio path between the audio port and the telephone. When it hears the cue tone or word, it opens the control contacts of the audio port to turn the recorder off, leaving the tape at the beginning of the next message.

If the telephone that has accessed the audio port hangs up before the end of message sequence is found, the tape will continue to run and cue itself for the next message. If no audio was heard from the tape (if the tape was blank or not connected), the control will be turned off when the phone hangs up.

Multiple copies of the message may be consecutively recorded on a long tape (which would need to be manually rewound at the end of the tape), or a single message may be recorded on a continuous loop tape.

Chapter 5: Testing Equipment and Installations

Note: Default options are assumed. If you have trouble with any of the following procedures, a previous user's programming may be the cause. Refer to Programming.

Testing Key Systems or PBX Lines

To test key system and PBX lines, connect TLS-4A lines to Tip and Ring of PBX or key system Central Office loop start trunks (E&M, DID, or ground start trunks cannot be tested with the TLS-4A.) If a ground reference is required, connect a 0.080-inch diameter pin tip probe to the chassis ground reference jack on the unit back panel (Figure 1). Figure 4 shows the pin connections for the alligator clip cables used to connect TLS-4A lines to a terminal block (cables not supplied). Figure 5 gives a generalized diagram for key system test connections.

Caution: When ringing is applied, the Ring lead of the modular jacks carries up to 95 VAC referenced to ground (alternating polarity). Be sure the TLS-4A power switch is off before handling any cord ends or alligator clip cables.

Manual Continuous Ring Test

- Connect a telephone to Line 1 of the TLS-4A.
- With Line 1 on-hook, press and hold the front panel switch in the MAN/RING position.
- Verify that the telephone rings continuously while the button is depressed and that the Line 1 indicator blinks.

Line Wiring/Basic Function Test

The following test is used with Tone or Rotary phones.

- Connect at least two telephones (or other telecom devices) to the TLS-4A.
- Go off-hook with one telephone and dial the first telephone number for the other telephone. Default numbers are 101, 102, 103, and 104 for Lines 1 through 4, respectively. Up to 16 digits can be programmed for each line, as described in Programming.
- Verify that a standard ring (2 seconds on, 4 seconds off) occurs at the other telephone.
- Go off-hook at the other telephone and verify that a connection is established.

- Go on-hook with both telephones. Repeat with other telephones and lines as necessary.

Nonstandard Ring Cadence Test

To test equipment that looks for particular ring cadences, proceed as follows:

Note: Line 1 is used to enter programming mode, but any line can be used for test. Lines 1 and 2 are used as examples in the steps below.

- Go off-hook on Line 1 and press and hold the MAN/RING switch position until the Line 1 light blinks.
-or-
- With Lines 2 - 4 on-hook, lift the handset on Line 1 and enter: **99##. Verify that the Line 1 light blinks.
- Select Line 2 with the command *02#, then program the desired ring cadence as described in Chapter 6, command 23.
- Enter a second phone number for Line 2. (The default for the second phone number is 202, the cadence is 1 second on, 1 off, 1 on, and 3 off.)
- Hang up.
- Go off-hook on Line 1 and dial the second phone number for Line 2.
- Verify that Line 2 rings with the programmed ring cadence.

Dial Pad Check

The following verifies that all seven frequencies generated by the tone pad are operating and that the telephone can receive audio signals.

- Connect the telephone under test into TLS-4A Line 1.
- Go off-hook on Line 1 and press and hold the MAN/RING switch position until the Line 1 light blinks.
- With a known working phone, select Line 2 for programming with the command *02#. Verify that the Line 2 light begins blinking.
- Enter the following command: *11#1234567890#. (This programs the first phone number for Line 2.)
- Make sure the number does not conflict with other telephone numbers that may have been programmed into the unit.
- Listen for a three-beep confirmation. Hang up.

- Go off-hook on the phone to be tested, wait for dial tone. Enter: 1234567890.
- Verify that dial tone stops, ringback tone is heard, and Line 2 rings after the last digit is dialed.
- Go on-hook.

Telephone Handset Check

- Telephone mouthpiece operation can be checked using the TLS-4A by any standard procedure (e.g., go off-hook, break dial tone, blow on the mouthpiece, and verify that sound is heard in the earpiece).

Call Progress Tone Test

- Go off-hook on Line 1 and dial any seven-digit number that is not assigned to a TLS-4A line.
- Listen for the programmed “Response to Invalid Number” (see command 31, in Chapter 6). If the number starts with “1”, there will be an eight-second delay between the last digit and when you hear the programmed response.
- Hang up the telephone.

Test Numbers

The following numbers are used to demonstrate or to test how a device responds to dial tone, busy tone, reorder tone, and silence. All of the numbers listed below are default settings and can be changed. To change the defaults for these commands, please see page 39 .

To test a device’s response to dial tone:

- Lift a handset from a phone on any of the lines and dial: 83781

To test a device’s response to busy tone:

- Lift a handset from a phone on any of the lines and dial: 83782

To test a device’s response to reorder tone:

- Lift a handset from a phone on any of the lines and dial: 83783

To test a device’s response to ringback tone:

- Lift a handset from a phone on any of the lines and dial: 83784

To test a device's response to silence:

- Lift a handset of a phone on any line and dial: 83785

Silent Off-hook Mode

If an indefinitely open, silent line (that is, a line that will not revert to dial tone after a timeout period) is desired for test purposes, this can be set up by selecting 2 (silent) when programming command 32. See Chapter 6 for more information.

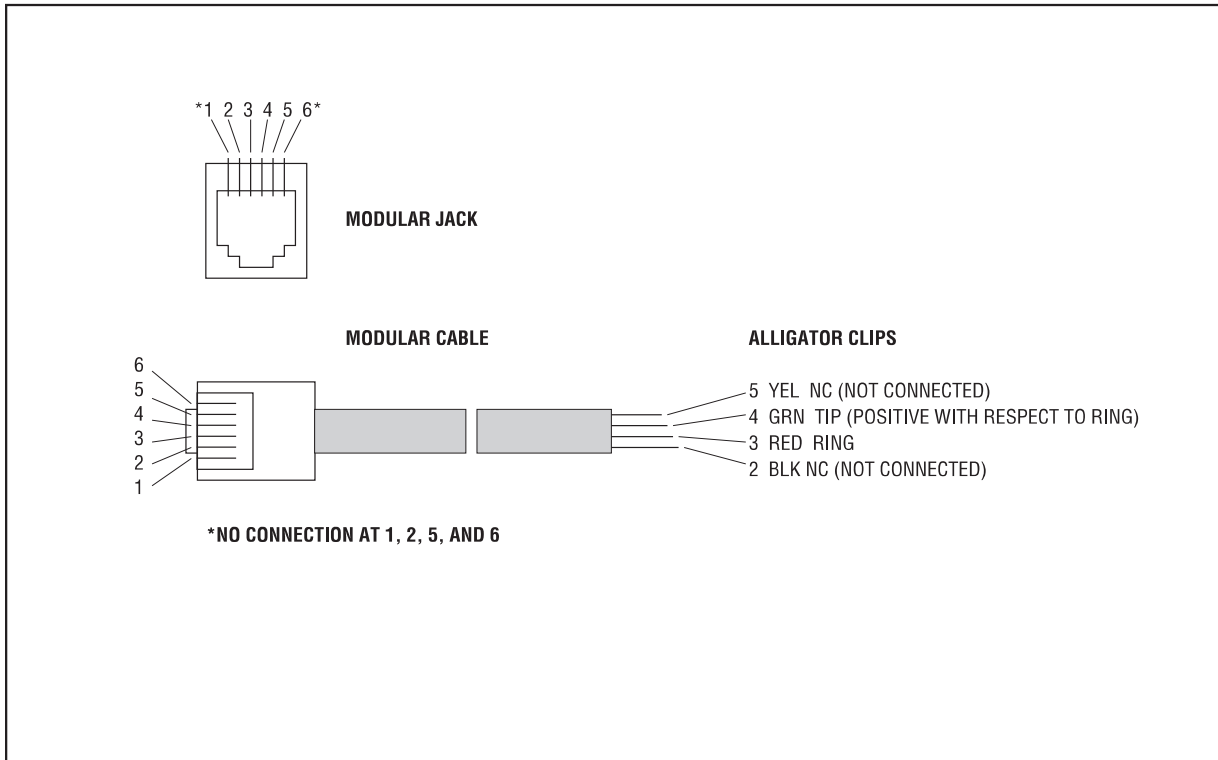

Figure 4 Clip Cable Connectors (Used with Terminal Block)

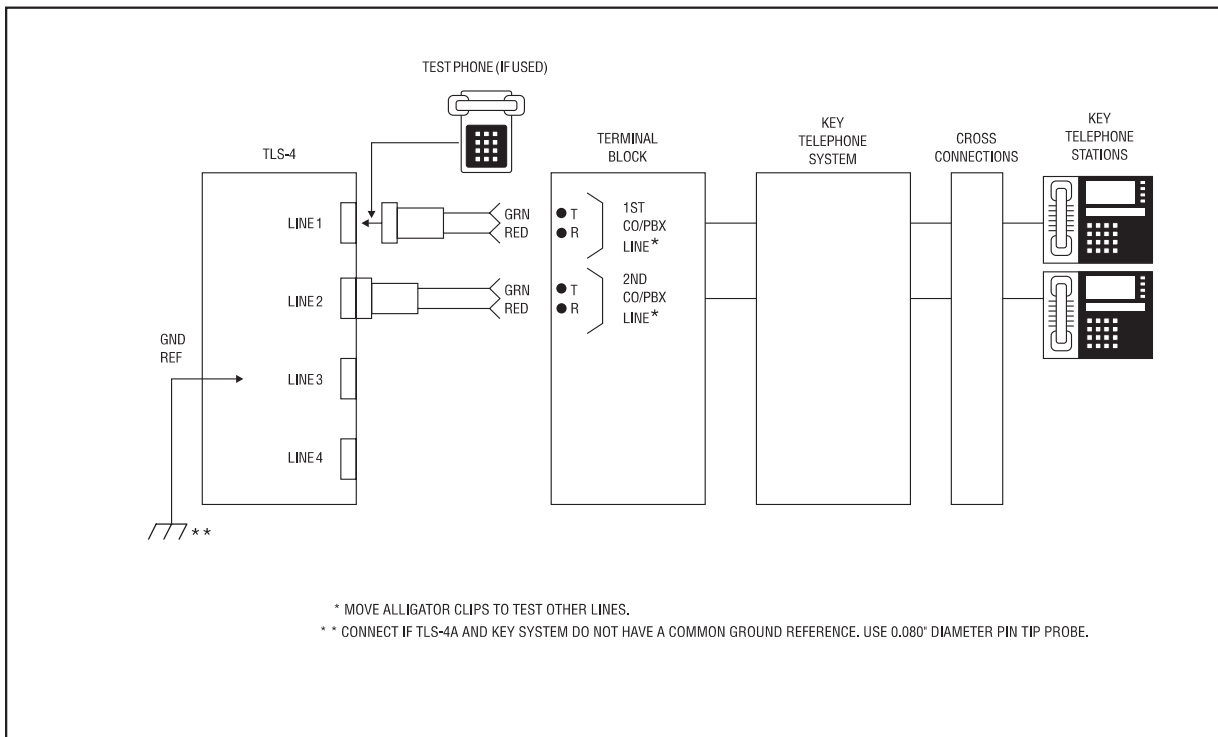

Figure 5 Key System Test Connections

Chapter 6: Programming

Optional features for the TLS-4A, including telephone numbers, are determined by programming the unit. This is done by accessing Program mode and keying command codes using a tone (DTMF) telephone plugged into the Line 1 jack.

Power Loss

Since the TLS-4A utilizes non-volatile memory, programming will not be lost during a power outage.

Note: All command codes must consist of two digits. That is, codes 00 through 09 must be entered as shown; entering 0 through 8 will not work.

Types of Commands

There are two types of commands 05 through 09, and 60 through 64 are effective systemwide; that is, they are set once for all four lines.

All others are “per-line commands”; that is, they must be set separately for each line.

Note: If command 08 is set to 0 (disabled), you will not hear three confirmation beeps nor the error tone.

To access Program mode

As explained below, there are two methods of accessing programming mode. Generally, you can use either one. The second method (**99##) *cannot* be used if the TLS-4A is programmed for “hot line” or direct audio port access on Line 1.

- Lift the handset of the Line 1 phone. Press and hold the MAN/RING switch position until you hear three beeps and the Line 1 light begins blinking. Line 1 is automatically selected.

-or-

- With Lines 2 through 4 on-hook. Pick up Line 1 and when you hear dial tone, dial: **99##
- Listen for three beeps and watch for the Line 1 light to blink.
- Enter any of the per-line programming commands (codes 11 through 90) for Line 1, or any of the systemwide programming codes.

- To enter any of the per-line programming commands for Lines 2 through 4, you must first select the line using commands 02, 03, or 04. While any of these lines is selected, you can also enter any systemwide programming command.

Command Format

For each feature to be programmed, a command is entered at the telephone keypad. All commands start with * and end with #. The # is also used to separate data fields if the command has more than one field. That is:

***<two digit command code>#<data field>#**

-or-

in the case of commands with multiple data fields:

***<two digit command code>#<data field>#<data field>#**

For example, to program 123 as the audio port access number, enter: ***06#123#**

To program the audio port to immediate access, multiple user, and disconnect at end of message, enter:

***05#1#1#1#**

Commands having multiple data fields can be abbreviated if the latter fields are to be set to zero. For example, ***05#2##** sets the audio access port to dial access, single user, disconnect at off-hook.

If the TLS-4A accepts the code, you will hear a confirmation tone of three short beeps. If the code is rejected, you will hear the error tone. If you hear error tone, verify that the code and values you are trying to enter are valid, and try again.

To correct command code mistakes:

If you made an error in entering the command code and have not yet entered a #, key * to cancel the command. When you hear three beeps, enter the command again.

To correct data field mistakes:

If you made an error in entering within a data field, (that is, after one or more #s have been entered prior to the final #, key * to erase the current field back to, but not including, the #, or ** to cancel the entire command. When you hear three beeps, re-enter the command.

To exit Program mode

When you are finished programming, hang up.

The program codes and options are summarized for quick reference in Appendix B.

Command Dictionary

With this table, you can look up a command by its number, name, or page number. The Description provides information explaining the basic use of each command. In-depth explanations are provided in the text on the indicated page.

There are two types of commands: systemwide and per-line. Command codes 00 through 09 and 60 through 64 are systemwide and can be entered with any line selected and with the unit in programming mode. All other commands are per-line-programmable features (command codes 11 and above); all commands entered are for Line 1 until another line (2 through 4) is selected.

Appendix B provides a quick reference list of commands.

Command Number	Command	Description	Page
Systemwide Commands			
	**99##	Use this command to enter programming mode.	28
00	Reset to defaults	Use this command to erase programming and return to the original settings. There is no default for this command.	28
01	Program Line 1	Enter this command to program Line 1. After you enter this command, you can enter others to change how Line 1 operates. There is no default for this command.	28
02	Program Line 2	Use this command to program Line 2. There is no default for this command.	28
03	Program Line 3	Enter this command to program Line 3. There is no default for this command.	28
04	Program Line 4	This command programs Line 4. There is no default for this command.	28

Command Number	Command	Description	Page
05	Audio Access Mode	This command sets which mode the audio port will be in when you access it and when you disconnect from it. There are three modes to choose from: monitor, immediate access, and dial access. The default is: dial access, one person can access the audio port at a time, and disconnect at on-hook.	29
06	Audio Port Access Number	Use this command to set the number you dial to access the audio port when the Audio Access Mode (command 05) is set to "dial access". The default number is 411.	30
07	Ring Type	Use this command to select the type of ringing that best fits your application. The default is x = 0, a 20 Hz synthesized sine wave	30
08	Confirmation and Error Tones	Use this command to have the TLS send confirmation tones or error tones after you enter a command. You turn this option on by entering *08#1#. The TLS will send confirmation tones after a command is entered correctly or an error tone if the command is incorrect. If you do not want to hear any tones, enter *08#0#. The default is enabled, you will hear confirmation and error tones.	31
09	Device Disconnect Timer	Use this command to set the amount of time that the TLS waits before sending a forced disconnect to the other device. The default is x=20 or 2 seconds.	31
Per-line commands			
<i>Note:</i> A line must be selected before using the following commands. See commands 01 - 04.			
11	First Phone Number	Use this command to program the first telephone number for all four lines. The default numbers are 101 - 104.	32
12	Second Phone Number	Use this command to program the second telephone number for all four lines. The default numbers are 201 - 204.	32
13	Dial Tone/Hot Line Number	This command has two functions. Use it to set a "hot line" number so that whenever a phone on that line is picked up, a programmed number is dialed. Or, use the command to send dial tone when the "Revert to Dial Tone Number" is dialed. The default number is 711.	32

Command Number	Command	Description	Page
20	Dial Tone Delay	Use this command to set the amount of time between when you lift the receiver (i.e., when you go off-hook) and when you hear dial tone. The default is 0.1 second.	33
21	Network Response Delay	Use this command to create a delay between the end of dialing and when you hear ringing, busy, or reorder tone. (This does not affect commands 60-64.) The default time for this delay is 0.2 second.	33
22	Second Dial Tone Delay	Use this command to set the time from the end of dialing until dial tone is sent back to the line when you dial the "Second Dial Tone Number". This command works with command 19. The default is 0.5 second delay.	33
23	Ring Cadence Second Phone Number	Use this command to set a different ring for the second numbers. The default ring is: 1 second on, 1 second off, 1 second on, 3 seconds off.	34
30	Response to Busy Signal	Use this command to set the response that calls from other lines will get when calling this line: busy signal or reorder tone. The default is a busy signal.	34
31	Response to Invalid Number	Use this command to set the tone heard if someone dials an Invalid number from this line. The options are: busy, reorder, ringback, silence, and connect to audio port. The default is reorder tone.	34
32	Off-hook (Hot Line/Silent/Normal)	Use this command when you want to pick up one phone and have another ring ("ringdown") or to use the line without hearing call progress tones and without hearing dial tone. The default is x=0 the TLS-4A operates normally.	35
33	Audio Port Permission	Use this command to allow or prevent dial access to the audio port. If you deny access and dial the number for the audio port, you will hear reorder tone. (This does not affect audio port access for invalid numbers.) The default is enabled so that callers can access the audio port.	36
34	Flash Detection	Use this command to turn flash detection on or off. The default is enabled, the TLS will detect a switchhook flash.	36

Command Number	Command	Description	Page
35	Hunt Mode	Use this command to set how a “hunt group” or group of phones sharing a single telephone number, responds when the shared telephone number is dialed. The default is ring all or “hunt mode”.	37
36	Attenuation	This command can be turned on or off. If it is turned on, the TLS will lower the volume (i.e., loudness) of a call. The default is disabled or no attenuation.	38
38	Forced Disconnect	Use this command to determine whether a line gets a forced disconnect when the <i>other</i> line hangs up. The default is forced disconnect on.	38
60	Dialtone Number	Use this command to program a number that will respond with continuous dial tone until you hang up. The default number is 83781 (TEST1).	39
61	Busy Tone Number	Use this command to program a number that will respond with busy tone until you hang up. The default number is 83782 (TEST2).	39
62	Reorder Tone Number	Use this command to program a number that will respond with reorder tone until you hang up. The default number is 83783 (TEST3).	39
63	Ringback Tone Number	Use this command to program a number that will respond with ringback tone until you hang up. The default number is 83784 (TEST4).	39
64	Silence Number	Use this command to program a number that will respond with silence until you hang up. The default number is 83785 (TEST5).	39
90	Clone Line X	Use this command to copy the programming from one line to the line you are calling from. For example, if you enter *90#1# from Line 2, the programming from Line 1 is copied to Line 2. There is no default for this command.	40
99	Programming Query	Use this command to find out how a particular command is set. This command does <i>not</i> work with commands 00-04. There is no default for this command.	40

Systemwide Commands

****99##: Programming Mode**

Use this command to enter programming mode from Line 1 with all other lines on-hook.

00: Reset to Defaults

This command resets the factory default operating conditions, either for the entire unit, or for one or more lines. Each command must be entered twice, as shown below.

- To restore all defaults, enter:
***00#0#*00#0#**
 - To restore defaults for Line 1, enter:
***00#1#*00#1#**
 - To restore defaults for Line 2, enter:
***00#2#*00#2#**
 - To restore defaults for Line 3, enter:
***00#3#*00#3#**
 - To restore defaults for Line 4, enter:
***00#4#*00#4#**
-

01 - 04: Select Line 1, 2, 3, or 4 for Programming

This command selects Line 1, 2, 3, or 4 so you can set any of the per-line-programmable features (commands 11-52, and 90, 99) for Line 1.

Note: Use this command only if you have previously selected another line for programming. On the first access to programming mode, Line 1 is automatically selected.

***01#**

The Line 1 light begins blinking. When you have finished programming Line 1, you can either (1) select another line, or (2) hang up to exit programming mode.

To select Line 2, enter:

***02#**

To select Line 3, enter:

***03#**

To select Line 4, enter:

***04#**

05: Audio Access Mode

Use this command to specify the methods of access to and disconnection from the audio port. This command is effective systemwide. You can also enable or disable each line's access to the audio port. See command 33, Audio Port Permission.

- To program audio access mode, enter the command:

***05#x#y#z#**

where: x = access mode

x = 0, monitor mode
 x = 1, immediate access
 x = 2, dial access (*default*)

y = connection mode

y = 0, single user (*default*)
 y = 1, multiple user

z = disconnect mode

z = 0, disconnect at on-hook (*default*)
 z = 1, disconnect at end-of-message

Monitor mode: The audio port is automatically connected to the first line on which the handset is lifted (if permitted by the setting of command 33) and the call, including dialing, will be recorded. To use this mode, the command must be entered as shown below:

***05#0#0#0#**

where: The command must be entered as shown above.

Immediate access: The audio port is connected directly to one or more lines (if permitted by the setting of command 33). No dial tone is given and dialing is ignored.

***05#1#y#z#**

where: *05#1#0#0# - One user gets immediate access and remains connected until on-hook

***05#1#0#1#** - One user gets immediate access and remains connected until end-of-tape message is heard

***05#1#1#0#** - Multiple users get immediate access remain connected until phones go on-hook

***05#1#1#1#** - Multiple users get immediate access and remain connected until end-of-tape message is heard.

Dial up access: Connects one or more users to the audio port (audio both to and from the port) after the user dials the audio access number (command 06). The default is $x = 2$.

***05#2#y#z#**

- where:** *05#2#0#0# - One user can dial up the port and remain connected until on-hook (default)
*05#2#0#0# - One user can dial up the port and remain connected until the end-of-tape message.
*05#2#0#1# - Multiple users can dial up the port and remain connected until on-hook.
*05#2#1#1# - Multiple users get immediate access and remain connected until end-of-message is heard.

Note: See “End-of- Message Sequence” on page 16, for more information.

06: Audio Port Access Number

This command sets the dial access number when the system is configured for “dial access” (see command 05).

- To set the dial access number, enter:

***06#x#**

where: x is a 1 to 16 digit number (digits 0 through 9), *default:* 411

- To delete the current audio port access number, enter:

***06##**

07: Ring Type

This command selects the ringing frequency. (The frequencies listed below are within 5% of nominal.) The square wave options are intended for use with certain devices that may not detect the synthesized sinewave.

***07#x#**

- where:** x=0, 20 Hz synthesized sinewave (*default*)
x=1, 25 Hz synthesized sinewave
x=2, 30 Hz synthesized sinewave
x=3, 60 Hz synthesized sinewave
x=4, 20 Hz squarewave
x=5, 25 Hz squarewave
x=6, 30 Hz squarewave
x=7, 60 Hz squarewave

Note: The 25-60 Hz frequencies are provided to simulate ringing frequencies used outside the United States.

08: Confirmation and Error Tones

This command determines whether or not the TLS-4A will return confirmation and error tones at the end of each programming command.

- To disable the function so that no tones will be given.

***08#0#**

- To enable the function so that tones will be given (*default*), enter:

***08#1#**

09: Device Disconnect Timer

This command sets the time that the TLS-4A will wait before sending a disconnect to a line remaining off-hook at the end of a conversation after other line(s) are on-hook. (*Default is 20 or 2 seconds.*)

Please refer to command 38, Forced Disconnect on page 38.

***09#x#**

where: x is a number between 10-200 representing tenths of seconds (For example, x=199=19.9 seconds)

Per-line Commands

Before entering any of the following commands, you must select a line by entering a 01, 02, 03, or 04 command. (See page 28.)

11: First Telephone Number

Each of the four TLS-4A lines can be rung by other lines upon dialing one of two numbers. The first number always rings the line with a standard single ring having a ring cadence of two seconds on, four seconds off. Enter the following to set the first number for the selected line:

***11#xx...x#**

where xx...x is any number up to 16 digits long. Any combination of digits 0-9 may be used.

Default: 101 through 104 for Lines 1 through 4, respectively.

12: Second Telephone Number

The second telephone number provides an alternate number that can be used to dial the line. Ring cadence can be varied for this number (unlike the first number); see command 23 on page 34. Enter the following to set the second number for the selected line:

***12#xx...x#**

where xx...x is any number up to 16 digits long. Any combination of digits 0 through 9 may be used, **default:** 201 through 204 for Lines 1 through 4, respectively.

13: Dial Tone/Hot Line Number Entry

This command can serve either of two purposes:

- If the dialing mode (see command 32 on page 35) has been set to “hot line”, whenever a caller on THIS line (the line you have selected for programming) picks up the handset, the TLS-4A will ring the number you enter with this command.

For example (assuming default phone numbers are in effect), to set Line 3 to ring Line 1 whenever the handset is lifted:

1. Enter programming mode.
2. Select Line 3 for programming: dial *03#.
3. Set dialing mode for Line 3 to hot line: *32#1#.
4. Set hot line number for Line 3 to 101 (first number) or 201 (second number): Dial *13#101# or *13#201#.
5. Hang up.

If the dialing mode, command 32, has been set to “normal”, a second dial tone is given on this line when the revert number is dialed.

The command format is:

***13#xx...x#**

where xx...x is any number up to 16 digits long. Any combination of digits 0 through 9 may be used. *Default: 711.*

20: Dial Tone Delay

This command establishes the interval from the time the receiver is lifted to the time dial tone is heard on the line. The actual time may be longer than that programmed if calls are also being set up on other lines.

- To set the dial tone delay, enter:

***20#x#**

where x is a number between 0-511 representing tenths of seconds (511 = 51.1 seconds). (*Default: 0.1 second*)

21: Network Response Delay

This command determines the delay time from end of dialing until a “network response” (ringback and ringing to the called line, busy, or reorder) for the *originating* port. This does not apply to the test numbers programmed by commands 60 - 64.

- To set the network response delay, enter:

***21#x#**

where x is a number between 0 and 511 representing tenths of seconds (511 = 51.1 seconds). *Default: 0.2 seconds.*

22: Second Dial Tone Delay

Sets the time from end of dialing until a second dial tone is returned to the line when the caller dials the dial tone number set by command 13. (Not applicable if the line is in hot line mode; see command 31 on page 36.)

The command is:

***22#x#**

where: x is a number between 0 and 255 representing tenths of seconds (255 = 25.5 seconds). *Default: 0.5 second.*

23: Ring Cadence, Second Phone Number

This command sets second phone numbers which can be programmed to ring a single, double, or triple ring, with on and off times as specified in this command:

***23#a#b#c#d#e#f#**

where: a is the “on” time of the first ring, b is the “off” time of the first ring, c is the on time of the second ring, and so on.

a, c, and e can be any numbers from 0 through 30 representing tenths of seconds (30 = 3.0 seconds).

b, d, and f can be any numbers from 0 through 63 representing tenths of seconds (63 = 6.3 seconds).

Default: 1 second on, 1 second off, 1 second on, 3 seconds off.

- To disable ringing, enter:

***23# #**

- To set the first on time and first off time to 30 and set the rest to 0 for continuous 3 second on/3 second off ringing, enter:

***23#30# #**

- To set the on time to 30 and the first off time to 0 (i.e., continuous ringing), enter:

***23#30#0# #**

30: Response to Busy

Determines the response that will be given to callers on *other lines* if this line is busy when dialed.

- To respond to callers with a busy signal (*default*), enter:

***30#0#**

- To respond to callers with a reorder tone, enter:

***30#1#**

31: Response to Invalid Number

This command determines the response that will be given to callers on *this line* who dial a number that does *not* match any of phone numbers programmed for the other lines.

The fourth response, connecting a caller to the audio port, can be used to play a recorded message or to simulate pre-recorded Special Information Tones (SITs) used by the telephone network. If a second invalid number is dialed while the first call is connected to the audio port, the second line will get busy tone.

Regardless of the response you select, there will be a delay before the response is activated. If an invalid number beginning with “1” is dialed, the TLS-4A will simulate the telephone network’s delay by waiting until 11 digits have been entered or 8 seconds have passed.

If an invalid number beginning with any number other than “1” is dialed, the TLS-4A will respond after 7 digits have been entered or after 8 seconds have passed.

There are four responses:

***31#x#**

- where** x = 0, callers will hear busy tone
 x = 1, callers will hear reorder tone (*default*)
 x = 2, callers will hear ringback tone
 x = 3, callers will hear silence
 x = 4, callers will be connected to the audio port.

32: Off-hook Modes

This command may be used for either of the following:

(1) To enable the line to ring another line without dialing (i.e., “ringdown mode” or “hot line”). A ringdown number must also be programmed; see (command 19).

(2) To provide a quiet battery feed source with no call progress tones and no response to dialing (“silent mode”).

A 0 setting provides normal dial operation.

- To disable ringdown and provide normal dial operation (*default*), enter:

***32#0#**

Note: To ensure that the line stays silent and cannot dial out if held off-hook at the end of a call, set the tone following disconnect command to silence:

***39#1#**

- To put this line in ringdown mode so that the TLS-4A automatically rings the number programmed in command 13 whenever the receiver is lifted on this line, enter:

***32#1#**

Note: To ensure that the line stays silent and cannot dial out if held off-hook at the end of a call, set the tone following disconnect command to silence:

*39#1#

- To put this line in silent mode so that no dial tone is provided and the line will not respond to dialing, enter:

*32#2#

33: Audio Port Permission

This command permits or denies access to the audio port. (This command does *not* affect the audio port access for command 31.)

- To disable audio access from this line, enter:

*33#0#

Note: If command 05, Audio Port Access, is set to monitor for tone (*05#3#y#z#), you will be unable to disable access.

- To enable audio access from this line (*default*), enter:

*33#1#

34: Flash Detection

This command determines whether or not the TLS-4A will recognize a “flash” issued on this line.

A flash is used to signal for services such as calling an attendant, setting up a conference call, or transferring a call. A flash can be executed **either** by using the FLASH button (on phones that have one) **or** by momentarily pressing the switch in the telephone handset cradle (don’t do both).

- To disable switchhook flash detection; callers on this line will not be able to transfer calls or exercise other PBX-like functions, enter:

*34#0#

Note: If you disable switchhook flash detection, the on-hook detect time will be shorter. In this situation, a switchhook flash could result in a disconnect.

- To enable switchhook flash detection (*default*), enter:

*34#1#

35: Hunt Mode

This command determines how the TLS-4A will respond when more than one line is programmed with the same number, in effect setting up a “hunt group”. In a hunt group, when a dialed line is busy, the system will attempt to ring other lines in the group until it finds an available line. For more information, see Chapter 2. There are four options:

This feature is activated from the line making the call and must be programmed on each line that makes calls in hunt mode.

Program the lines between which you want to hunt with the same number, either first or second.

Note: All numbers in a hunt group must be programmed in the same number type: they must all be first or second numbers.

For example: To setup a hunt group consisting of Lines 3 and 4, enter *03# to select Line 3.

*12# 789#, second number is 789

*04#, select Line 4

*12# 789#, second number is 789

Note: If you pick up one of the phones in the hunt group and place a call to the hunt group number, the next higher line will ring. If you pick up the phone on Line 3 from the hunt group in the above example and call 789, Line 4 will ring.

- To disable hunt mode so that the TLS-4A will only attempt to ring the first line that has this number, enter:

*35#0#

- To cause the TLS-4A to ring simultaneously **all** lines programmed with this number. The first line to answer will be connected; all others will revert to normal operation (*default*), enter:

*35#1#

- To cause the TLS-4A to ring the *first available line* that has this number, starting from Line 1, enter:

*35#2#

- To cause the TLS-4A to ring the *next available line* that has this number; that is, the next higher line number after the last one used (if Line 2 was the last line rung, Line 3 will be rung), enter:

***35#3#**

36: Attenuation

This command turns down the volume of sound transmitted on this line. When there are two active calls, the TLS-4A will apply attenuation to both calls; however, attenuation will not be doubled if one attenuated line calls another.

- To disable attenuation (*default*), enter:

***36#0#**

- To enable attenuation, enter:

***36#1#**

38: Forced Disconnect

This feature determines whether this line gets a forced disconnect when the *other* line goes back on-hook.

- To enable (*default*) forced disconnect, enter:

***38#1#**

Note: The TLS-4A cannot ring one line while sending a forced disconnect to another. If these actions are attempted simultaneously, either the ringing or the forced disconnect will be delayed until the other is finished.

- To disable forced disconnect, enter:

***38#0#**

39: Tone Following Disconnect

This command sets the tone that will be heard after a forced disconnect or, if forced disconnect is disabled, the tone will be heard after the delay before disconnect.

If x=4, the caller will be connected to the audio port and will hear any announcement you have recorded.

***39#x#**

where: x=0, dialtone (*default*)

 x=1, busy

 x=2, reorder

x=3, silence
x=4, audio port

60: Dial Tone Number

This command programs a number that you can dial to hear continuous dialtone. This is used to test or demonstrate how a device responds to continuous dialtone.

***60#x#**

where: x = 0-16 digits
83781 or "TEST1" (*default*)

61: Busy Tone Number

This command programs a number that you can dial to hear busy tone. It is used to test or demonstrate how a device responds to busy tone.

***61#x#**

where: x = 0 -16 digits
83782 "TEST2" (*default*)

62: Reorder Tone Number

This command programs a number that you can dial to hear reorder tone. It is used to test or demonstrate how a device responds to reorder tone.

***62#x#**

where: x = 0 - 16 digits
83783 or "TEST3" (*default*)

63: Ringback Tone Number

This command programs a number that you can dial to hear ringback tone. It is used to test or demonstrate how a device responds to ringback tone.

***63#x#**

where: x = 0 - 16 digits
83784 or "TEST4"

64: Silence Number

This command programs a number you can dial to hear silence. It is used to test or to demonstrate how a device responds to silence on the line.

***64#x#**

where: x = 0 - 16 digits
83785 or "TEST5"

90: Clone Line X

This command copies the features programmed for another line to this line.

Note: When a line is cloned, the line's telephone number are *not* cloned.

- To copy Line 1 programming to this line, enter:

***90#1#**

- To copy Line 2 programming to this line, enter:

***90#2#**

- To copy Line 3 programming to this line, enter:

***90#3#**

- To copy Line 4 programming to this line, enter:

***90#4#**

99: Programming Query

This command is used to find out the current setting for any programmable feature. The TLS-4A will give a voice response to query commands.

- Enter the query command as:

***99#xx#**

where: xx is any command code.

The following commands give special results:

***99#99#**, A voice speaks digits 0 through 9.

***99#98#**, A voice speaks the firmware version number.

***99#00#**, 8 seconds of 1 kHz tone are returned.

Codes 01 through 04 are not applicable query commands.

Chapter 7: Warranty, Troubleshooting, and Return

Warranty Information

Troubleshooting

Before you return a unit, check the fuse.

If the POWER light does not come on when the unit is plugged in and turned on, try changing the fuse. The active fuse, and a spare, are both located in a holder on the back panel of the unit, below the power plug, as shown in Figure 6.

1. To remove the fuse holder, insert the blade of a small screwdriver into the groove at the bottom of the power plug and push outward.
2. The active fuse is the one farthest from the labeled panel; the other fuse is the spare. Remove the active fuse by pushing on either end.
3. Remove the spare fuse and insert it into the active fuse holder.

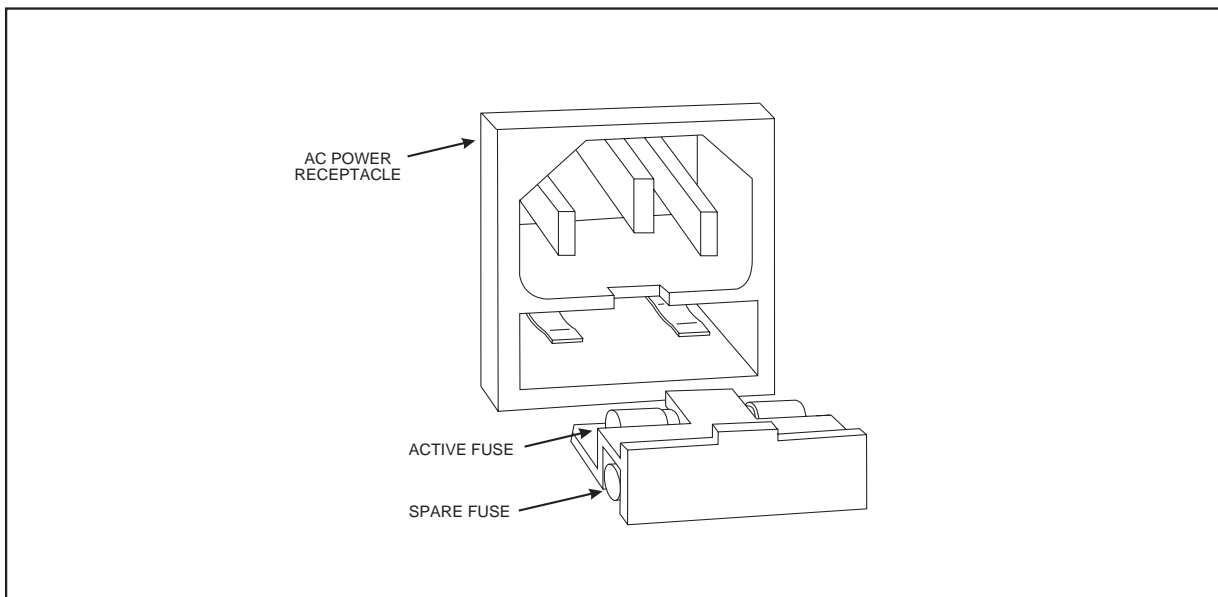

Figure 6 Fuse Holder Location

Note: If there is no spare fuse in the holder, obtain a replacement fuse of the following type: 5 x 20 mm, 0.25 Ampere, slow blow. Please see Chapter 9 for recommended replacement fuses.

4. Return the fuse holder to the opening in the TLS-4A back panel.
5. If the POWER light still does not come on, return the unit for repair as instructed below.

Chapter 8: Electrical Specifications

AC Power Input

Voltage	TLS-4A: 115 VAC (15%)
Frequency	49 to 61 Hz
Current	TLS-4A: 0.2 A maximum (nominal line voltage)
Fusing	0.25 A 5 x 20 mm slow blow
Unit dissipation	20 Watts maximum

Telephone Line Circuit (Loop Start)

On-hook voltage	-48 (5 Volts (Tip positive referenced to Ring)
Short circuit loop current	< 30 milliamps
Minimum loop current	18 milliamps with a 500-ohm loop

Transmission Specifications

Nominal impedance	900 ohms
Insertion loss	Switchable between 3.4 dB and 16 dB (2 dB @ 1 kHz when two lines are connected)

Ring Source

Ring voltage	78 VAC (10% AC @ 20 HZ sinewave)
Ring frequency	Selectable 20, 25, 30, 60 (5% Hz)
Drive capacity	Up to 5 ringer equivalents (5 REN) total @ 20 HZ sinewave
Ring termination on answer	Within 250 ms
Ring waveform	Selectable step approximated sine or square wave

DTMF Detection

Frequency accept	(1.5% + 2 Hz)
Frequency reject	(3.5%
Tone-on time	40 ms minimum
Tone-off time	40 ms minimum
Amplitude	+4 to -18 dBm per frequency
Twist	6 dB or less

Rotary Dialing Detection

Rate	8 to 22 PPS
Percent break range	40% to 80% (LSSGR 6.3.4.6)
Break time	18 ms minimum, 100 ms maximum
Make time	9 ms minimum, 75 ms maximum
Interdigit time	300 ms minimum
End-of-digit detection	100 ms minimum

Loop Current Detect

Minimum off-hook current	15 mA
Maximum on-hook current	10 mA
Off-hook detect time	100 ms max
On-hook detect time	>Flash
Hook flash detect time	300 - 1100 ms (must detect) <280 ms > 1120 must not detect

Ringling Cadence

Ring programming increment	100 ms
Rings per cycle	1 to 3 (programmable)
Ring "on" time	0 to 3 seconds
Ring "off" time	0 to 6.3 seconds

Call Progress Tone Characteristics (Tone levels referenced to 900 ohms)

Dial tone	350 Hz (0.5% and 440 Hz (5% at -19 (3 dB per tone
Busy and reorder tone	480 Hz (0.5% and 620 Hz (5% at -19 (3 dB per tone
Audible ringback tone	440 Hz (0.5% and 480 Hz (5% at -19 (3 dB per tone

Audio Input/Output Jack

Recorder tone	230 ms of 1050 - 1650Hz tone to activate
Audio In impedance	10 k ohms
Audio gain (jack to Tip/Ring)	~ -10.5 dB (-10 dBm out with 1 V in)
Audio Out impedance	600 ohms
Audio gain (Tip/Ring to jack)	~0 dB
Relay contact rating	1 Form A contact, 100 Volt maximum, 1 mA maximum, 30 volt-amps maximum

Connector pinout	Pin 1: relay contact Pin 2: ground Pin 3: relay contact Pin 4: audio in to TLS-4A Pin 5: audio out from TLS-4A Shell ground: ground
------------------	--

Mechanical Specifications

Dimensions	2.3" H x 8.5" W x 10 .0" D (58 x 22 x 254 mm)
Weight	4 lb. 5 oz. (unit only)

Environmental Specifications

Storage temperature:	
Short-term storage	-40 to +55 degrees C
Long-term storage	-20 to +50 degrees C
Operating temperature	0 to 45 degrees C
Humidity	85% noncondensing, maximum

Regulatory Specifications

Meets requirements of U.S. Federal Communications Commission (FCC), Part 15 Class A, UL 1244, and CSA, C22.2, No. 225.

Chapter 9: Ordering Information

TLS-4A Telephone Line Simulator with power cord, includes an AC power cord and reference manual (this document). This unit accepts 115 VAC.

Optional Components

AC110-7.5 (spare) AC power cord, three-pronged, power cord (No. 18-3), type SVT rubber, with NEMA 5-15 P male/SPH-386 female connectors.

TLS-CA1 (optional) Modular/alligator clip cable (P/N 208-00121-01), 4-1/2 ft. cable with RJ-11 jack at one end, color-coded alligator clips at the other. (One cable required for each test line.)

Replacement Fuses

Below are a list of fuses, with their part number and manufacturer's name, which you can purchase from an electronics distributor.

Bussman	GMD-250mA
SAN-O Industrial Corporation	SD6-250
Littlefuse	239.250
Bel	5TT-250MA

Appendix A: Glossary

Some terms in this glossary were defined with the assistance of *Newton's Telecom Dictionary*, by Harry Newton. To order a copy, call 1-800-LIBRARY or write to: Telecom Library Inc., 12 West 21 Street, New York, New York 10010.

2500 set

The standard single-line touch-tone desk telephone.

Busy Tone

A signal generated by the Central Office indicating that the line you are calling is busy.

Call Progress Tone

A tone sent from the switch to tell the caller of the progress of the call. Examples are audible ringing, re-order, busy, timing, etc.

Central Office

Telephone company facility where subscribers' lines are joined to switching equipment for connecting other subscribers to each other, locally and long distance. (Also called CO.)

DTMF

Also called touch-tone. Dual-tone multi-frequency. Push-button telephone signaling.

Forced disconnect

Method used by the telephone company to clear a line. When the called party goes on-hook, the Central Office returns an open (that is, drops loop current) of at least 800 ms to the calling party. This is also known as Calling Party Control (CPC), or Cutoff On Disconnect (COD), or Disconnect Supervision.

Ground start

One of two types of switched telephone lines (outside lines) typically leased from telephone companies, the other type being loop start. A ground start telephone line initiates an outgoing telephone line seizure by applying a local resistance up to 550 ohms from ground to the tip conductor.

Key telephone system

A telephone system in which the telephones have multiple buttons that permit a user to select outgoing or incoming Central Office phone lines directly.

LED or light

Light-emitting diode. A semiconductor diode that emits light when a current is passed through it. Used for status and information displays on electronic devices.

Loop start

One of two types of switched telephone lines (outside lines) typically leased from telephone companies, the other type being ground start. A loop start telephone line is seized by connecting a low resistance between the tip and ring (both wires) of the telephone line. This occurs whenever a telephone or modem goes off-hook. If you need to find out if a line is loop start, call the telephone company.

Off-hook

The telephone is in an off-hook state when the handset is removed from the cradle. A modem or other device is off-hook when it answers a call or when it seizes a line to initiate a call.

Public Switched Telephone Network (PSTN)

Usually refers to the worldwide voice telephone network accessible to all those with telephones and access privileges (In the U.S., it was formerly called the Bell System network or the AT&T long distance network.)

Reorder Tone

A tone that sounds like the busy signal, but is twice as fast. It indicates that all switching paths are busy. If you hear a reorder or fast busy, hang up and dial the number again.

Appendix B: Programming Quick Reference

Description	Command	Option	Default
Systemwide commands			
Reset to Defaults	*00#x#*00#x#	x=0, reset entire unit x=1, reset Line 1 x=2, reset Line 2 x=3, reset Line 3 x=4, reset Line 4	—
Select Line 1 for programming	*01#	—	—
Select Line 2 for programming	*02#	—	—
Select Line 3 for programming	*03#	—	—
Select Line 4 for programming	*04#	—	—
Audio Access Mode	*05#x#y#z	x = 0, monitor mode (y & z must be 0) x = 1, immediate access x = 2, dial access y =0, single user y =1, multiple user z = 0, disconnect at on-hook z = 1, disconnect at end-of-message	dial access, single user, on-hook *05#2#0#0#
Audio Port Access Number	*06#x#	x = 0-16 digits	411 *06#411#
Ring Type	*07#x#	x = 0, 20 Hz synthesized sinewave (<i>default</i>) x=1, 25 Hz synthesized sinewave x=2, 30 Hz synthesized sinewave x=3, 60 Hz synthesized sinewave x=4, 20 Hz squarewave x=5, 25 Hz squarewave x=6, 30 Hz squarewave x=7, 60 Hz squarewave	x = 0, 20 Hz synthesized wave
Confirmation and Error Signals	*08#0#	disable	enable *08#1#
	*08#1#	enable	
Disconnect Timer	*09#x#	x=10 - 200 (1 to 20 seconds)	(2 seconds) *09#20#
Per-line commands			
First Phone Number	*11#xx...x#	x = 0 to 16 digits (0 through 9)	101-104
Second Phone Number	*12#xx...x#	x = 0 to 16 digits (0 through 9)	201-204

Description	Command	Option	Default
Dial tone/Hotline Number	*13#xx...x.#	x = 0 to 16 digits (0 through 9)	711
Dial Tone Delay	*20#x#	x = 0 to 511 (51.1 seconds)	0.1 sec
Network Response Delay	*21#x#	x = 0 to 511 (51.1 seconds)	0.2 sec
Second Dial Tone Delay	*22#x#	x = 0 to 255 (25.5 seconds)	0.5 sec
Ring Cadence, Second Phone Number	*23#a#b#c#d#e# f#	a, c, e = 0 to 30 (3 seconds) b, d, f = 0 to 63 (6.3 seconds)	1 sec on, 1 sec off, 1 sec on, 3 sec off
Response to Busy	*30#0#	busy tone	busy *30#0#
	*30#1#	reorder tone	
Response to Invalid Number	*31#x#	x = 0, busy x = 1, reorder x = 2, ringback x = 3, silence	reorder *31#1#
Off-hook (hotline/silent/ normal)	*32#0#	normal	normal *32#0#
	*32#1#	hotline (ringdown)	
	*32#2#	silent	
Audio Port Permission	*33#0#	disable	enable *33#1#
	*33#1#	enable	
Flash Detect	*34#0#	disable	enable *34#1#
	*34#1#	enable	
Hunt Mode	*35#x#	x = 0, off x = 1, ring all x = 2, ring first available x = 3, ring next	ring all *35#1#
Attenuation	*36#0#	disable	disable *36#0#
	*36#1#	enable	
Forced Disconnect	*38#0#	disable	enable *38#1#
	*38#1#	enable	
Tone Following Disconnect	*39#x#	x = 0, dial tone x = 1, busy x = 2, reorder x = 3, silence x = 4, audio port	dial tone *39#0#
Dial Tone Number	*60#x#	x = 0 - 16 digits	83781 or "TEST1"

Description	Command	Option	Default
Busy Tone Number	*61#x#	x = 0 - 16 digits	83782 or "TEST2"
Reorder Tone Number	*62#x#	x = 0 - 16 digits	83783 or "TEST3"
Ringback Tone Number	*63#x#	x = 0 - 16 digits	83784 or "TEST4"
Silence Number	*64#x#	x = 0 - 16 digits	83785 or "TEST5"
Clone Line x	*90#x#	x = 1, clone from Line 1 x = 2, clone from Line 2 x = 3, clone from Line 3 x = 4, clone from Line 4	—
Programming query	*99#x#	x = any valid command code (05 and higher)	—

Index

A		H	
Access Numbers		Hunt Mode	
Busy Tone	39	ring first/ring all	6
Accessing programming mode	22	ring next	6
Application examples	4, 5	Hunt mode programming	36
Attenuation of line volume		I	
enable/disable	38	Illustrations	
simultaneous calls	38	Fuse holder location	41
Audio port		Indicators	3
invalid number	35	Installation	7, 9
procedure for using	12	Installation tests	
Audio port access		call progress tone	19
Enable/disable	36	Invalid Number	
Mode select	29	audio port	35
number entry	30	response delay	5, 35
C		Simultaneous calls to audio port	5
Call transfer procedure	10	K	
Calling operations	2	Key system testing	8
Cancel command	23	L	
Cassette tape		LED indicators	3
generating from telephone	13	Lights3	
generating on tape recorder	12	M	
Clone line X		MAN/RING switch	3
Copy programming	40	N	
Command format	23	Network response delay	
Conference call setup	10	Set time	33
Confirmation/error tone		O	
Enable/disable	31	Off-hook modes setting	
Copy programming	40	Ringdown	35
Correct programming mistakes	23	Silent mode	36
D		On/off switch	3
Demonstrating equipment		Ordering information	
call transfer	10	optional	46
conference call setup	10	P	
enable flash detection	11	PBX line testing	8
general	7	Per-line programming commands	33, 34, 35, 36, 40
Dial tone delay		How to enter	32
Set time	33	Playing a message	
Dial tone/hot line number entry	32	From Audio Port	14
E		Power switch	3
End-of-message tape sequence	16	Primary telephone number entry	32
Equipment tests		Product support	43
dial pad check	18	Program/Select	
nonstandard ring cadence	18	Line 1	28
telephone handset	19	Line 2	28
Exit from programming mode	24	Line 3	28
F		Programmable operations	2
Flash detection		Programming	23, 32
Enable/disable	36	Cancel command	23
Flash detection		Command format	23
enable	11	correcting mistakes	23
Forced Disconnect		query	40
programming	38		
Fuse			
How to change	41		

quick reference table	48, 49	Switches	3
Programming	28, 29, 33, 34, 35, 36, 40	Switchhook flash detection	
Programming mode		Enable/disable	36
Accessing	22	Systemwide programming commands	28, 29
exiting from	24		
Q		T	
Quick reference	48, 49	Tape	
R		generating from telephone	13
Recorder Tone	45	generating on tape recorder	12
Regulatory compliance information	iv	Tape Recorders	
Response to busy	34	compatibility	12
Response to invalid number		Technical Support	43
delay	34	Telephone number entry	32
Restore defaults	28	Test Numbers	
Return procedures		busy tone	19, 39
U.S. customers	42	dialtone	19, 39
Revert to dial tone delay		reorder tone	19, 39
Set time	33	ringback tone	19, 39
Ring Cadence		silence	20, 39
Second phone	34	Testing	
Ring cadence, secondary phone number	34	installation	8
S		TLS-4	
Safety instructions	iii	Applications	1
Secondary telephone number entry	32	Basic function	1
Select		Calling operations	2
See also Program/Select		connecting equipment	2
Silent line setup	20, 36	Features	1
Specifications	44, 45	physical description	2
Static		Tone Following Disconnect	38
protection from	1	Troubleshooting	41
		W	
		Warranty information	41