

Operating Manual



ServSwitch UPS

RMUPS1000, RMUPS1500
RMUPS2500, RMUPS3000
RMUPS4000, RMUPS5000 & RMUPS6000

Introduction

This user manual has been written to provide basic information about the RMUPS UPS.

It will describe the key features of the UPS, as well as detail referring to unpacking and installation, operation & configuration and troubleshooting. It also includes a section on software installation and general connectivity.

The specification section outlines all of the detailed parameters of operation of the RMUPS UPS and provides general information on approvals and certification.

The UPS should be installed according to the instructions in this manual. Failure to do so could result in safety issues. It could also invalidate your warranty.

Safety Information

Please retain this user manual in close proximity of the UPS for future reference.

Since the UPS unit operates from mains power and contains a number of high current back-up batteries, the information in this chapter is important to all personnel involved. Please take the time to read this section before unpacking, installation and operation of this UPS.

Storage and transportation

Because of the high energy stored within the batteries, the UPS equipment must be handled with due care and attention. The UPS must always be kept in the position marked on the external packaging and must not be dropped.

Installation

Do not operate the equipment in the presence of flammable gases or fumes. Operation of any electrical equipment in such an environment constitutes a safety hazard. Do not place the UPS in an unventilated room or enclosure.

The UPS must be installed in accordance to the instructions within this manual. Failure to recognise the electrical hazards could prove fatal.

Do not remove or unplug the input cord when the UPS is turned on. This removes the safety ground from the UPS and the equipment connected to the UPS.

Do not open the UPS cabinet. Some components inside the UPS cabinet carry high voltage. To touch them may prove fatal. All operations inside the UPS must be carried out by an authorised service engineer from the manufacturer or agent authorised by the manufacturer.

Batteries

Once batteries have reached the end of their life, ensure they are disposed of properly. Refer to your local codes for disposal requirements.

Never dispose of batteries in a fire. Batteries may explode when exposed to flame.

Replace batteries with the same number and type of batteries or battery packs as originally installed in the equipment.

Information de sécurité

Veillez garder ce manuel d'utilisation près de l'UPS .

L'UPS fonctionnant à partir du réseau et contenant des batteries à fort courant, les instructions de ce chapitre sont importantes pour tous les personnels impliqués. Veuillez prendre le temps de lire cette partie avant de déballer, installer et mettre en route cet UPS

Stockage et transport

A cause de l'énergie stockée dans les batteries, l'équipement doit être manipulé avec précaution. L'UPS doit être à tout moment maintenu dans la position mentionné sur l'emballage et ne doit pas chuter.

Installation

Ne pas utiliser l'équipement en présence de gaz ou vapeurs inflammables. L'utilisation d'équipements électriques dans un tel environnement est dangereux. Ne pas placer l'UPS dans un local fermé ou non ventilé.

L'UPS doit être installé suivant les instructions de ce manuel. Tout manquement à ces instructions peut s'avérer fatal.

Ne pas enlever ou débrancher le cordon d'entrée quand l'UPS est en marche. Ceci retire la masse de sécurité de l'UPS et de l'équipement connecté à celui-ci.

Ne pas ouvrir l'habillage de l'UPS. Certains composants de l'UPS sont à des tensions élevées, les toucher peut être fatal. Toutes les manipulations à l'intérieur de l'UPS doivent être faites par les personnels autorisés par le fabricant.

Batteries

Dès que les batteries ont atteint leur fin de vie , s'assurer qu'elles soient débarrassées proprement. Se référer aux règles locales en vigueur à ce sujet.

Ne jamais mettre les batteries dans le feu, elles peuvent exploser en présence d'une flamme.

Remplacer les batteries ou les pack batteries par la même quantité et le même type que celles installées dans l'équipement d'origine.

Sicherheitsinformationen

Bitte bewahren Sie diese Bedienungshinweise in der Nähe der USV auf.

Da die USV mit Netzspannung betrieben wird und Hochstrom-Backup Batterien enthält sind die Informationen in diesem Kapitel für alle damit in Berührung kommenden Personen von grösster Wichtigkeit. Bitte nehmen Sie sich die Zeit diese zu lesen bevor Sie die Anlage auspacken, installieren und in Betrieb nehmen.

Lagerung und Transport

Durch die hohe Energie die in den Batterien enthalten ist, muss die USV mit der erforderlichen Sorgfalt behandelt werden. Die USV muss immer in der auf der Verpackung markierten Position gelagert und transportiert werden und darf nicht gestaucht oder geworfen werden.

Installation

Die USV darf nicht in der Nähe von entflammaren Gasen oder Dämpfen betrieben werden. Der Betrieb in solchen Umgebungen stellt ein Sicherheitsrisiko dar. Die USV Anlage darf nicht in unbelüfteten Gehäusen oder Räumen betrieben werden.

Die USV muss entsprechend den in dieser Bedienungsanleitung aufgeführten Anweisungen installiert werden. Fehler beim Beachten der elektrischen Vorgaben können schwerwiegende Folgen haben.

Entfernen Sie nicht das Netzeingangskabel während die USV in Betrieb ist, da Sie dadurch den Schutzleiter zur USV und zu den an der USV angeschlossenen Geräte unterbrechen.

Öffnen Sie nicht das USV Gehäuse. Manche internen Teile führen Hochspannung. Die Berührung dieser ist gefährlich. Alle Arbeiten in der USV müssen durch einen Service Ingenieur des Herstellers oder vom Hersteller autorisierten Unternehmen durchgeführt werden.

Batterien

Wenn die Batterien ersetzt werden müssen, stellen Sie die ordnungsgemäße Entsorgung sicher. Beachten Sie hierzu die gültigen Entsorgungsvorschriften.

Werfen Sie Batterien niemals ins Feuer, da Batterien explodieren können wenn Sie mit Feuer in Berührung kommen.

Ersetzen Sie die Batterien nur mit der selben Menge und Type oder Batteriepacks, die im Original in dem Gerät eingebaut waren.

Contents

1. General Description	11
1.1. Basic functions of UPS	11
1.2. General technical overview	11
1.3. Key features of the RMUPS.....	13
2. Storage and Unpacking	15
2.1. Boxes supplied	15
2.2. What's in the box(es)	16
3. Installation and Set-up	18
3.1. Environment & positioning	18
3.2. Free-standing configuration	18
3.3. Rack-mount configuration	20
3.4. Rear panel features	21
3.5. Power connection RMUPS1000 & 1500	22
3.6. Power connection RMUPS2500 & 3000	23
3.7. Power connection RMUPS4000-6000	25
3.8. Communications Connectivity.....	27
3.9. REPO.....	30
4. Operation	32
4.1. Description of front panel features	32
4.2. Starting UP the UPS.....	32
4.3. Shutting Down the UPS	33
4.4. Using the front panel.....	35
4.5. Audible Alarms.....	39
4.6. On mains operation	40
4.7. On battery operation	41

Contents

5. Trouble shooting.....	42
5.1. Basic trouble shooting guide.....	42
5.2. LCD trouble shooting guide	44
5.3. Replacing batteries	46
6. Specification.....	48
6.1. General specification	48
6.2. Run time chart	49
6.3. Dimensional drawings.....	50
6.4. Fixing centres & dimension tables	50
7. Contact Information.....	52
8. Index.....	54

1. General Description

1.1. Basic function of the UPS

An Uninterruptible Power Supply is designed to provide a battery based source of AC power, such that under mains fail conditions the load can be supported for a specified period of time.

This time is generally dictated by the period required to shutdown equipment in an orderly fashion, generator-starting time or for an engineer to attend site. In a high percentage of cases, utility failure is often less than 5 minutes.

This period is often only a “bridge” between mains fail and generator starting.

1.2. General technical overview

Under normal conditions mains is fed into the rectifier which provides DC power to the Inverter and DC (via the charger) to charge the batteries. The inverter then feeds the load continuously. If the primary mains supply fails, the UPS simply uses the secondary supply (if connected) thus maintaining power to the load without using it's batteries.

If the auxiliary and primary supply fail, then the UPS continues to supply the load via the inverter but the inverter now takes its power from batteries (via the boost converter) not the rectifier. The load therefore sees no change. The static switch or auto bypass provides a fail-safe mechanism in UPS overload or UPS fault conditions of Inverter fail, rectifier fail & battery failure.

This On-line topology of UPS provides a true sinewave output.

General Description

1.2. General description – RMUPS Block Diagram

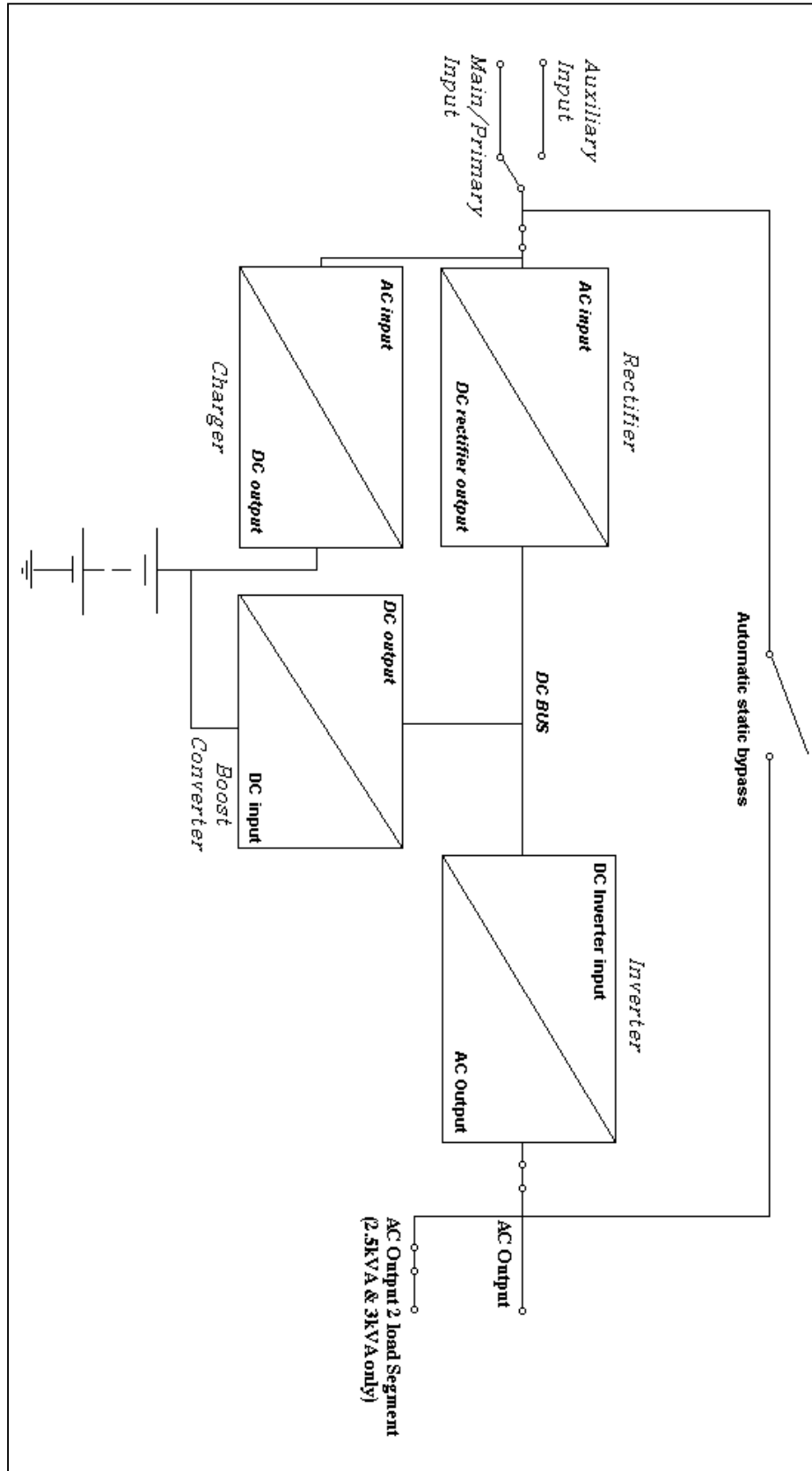

General Description

1.3. Key Features of the RMUPS1000 to RMUPS6000

Self configuring battery pack. All UPS' utilise batteries and, depending on the power rating of the UPS, the internal DC "string" voltage will be different: the higher the voltage, the lower the current needs to be in order to deliver the same power and consequently the UPS is less bulky and more efficient. To optimise efficiency, the higher the kVA rating of the UPS, the higher the "string" voltage used.

In the RMUPS design, the battery pack is configured in multiples to achieve the required string voltages at higher kVA ratings.

The advantage of this is:

1. The right battery packs are always available.
2. The blocks are "plug and play" so installation is very fast.
3. Technical installations people are not needed to install/change the batteries
4. The packs are small enough that they are considered a "one man lift" so shipping & installation is much easier.

Dual mains input. Most UPS' have one mains input, however the RMUPS has 2. It is common for comms rooms to be fed from 2 supplies (possibly 2 phases of the same supply) so that if there is a problem on one supply the other can take over and prevent the UPS from needing to discharge its batteries until there is no other option. In order to do this, ordinarily, a static switch is required which selects "Mains 1" or "Mains 2" as the input to the UPS depending upon which is available. Since RMUPS has 2 mains inlets, it is not necessary to have a static switch.

The advantages of this are:

1. Cost. No additional static switch
2. Less rack space. A typical static switch would be either 1U or 2U in height, once installed in the rack this takes away space which could be used by other equipment
3. The UPS is never running from battery (which has a finite life to it) when there is another mains supply available. Extended "uptime" for the load and extended lifetime for the batteries.

General Description

1.3. Key Features cont....

Multi format. All models are multi-format design and can be rack-mount or free-standing straight from the box; this achieves 3 important objectives:

1. Cost reduction by standardisation of packaging.
2. Cost reduction by minimisation of stock levels (the right format is always available !)
3. Fits all standard (600x600) racks as all models (UPS and Battery Packs) are only 510mm deep.

This also gives the flexibility to remove a UPS from a rack when space becomes limited and give the option of free-standing it, without the need to purchase a different model.

Rotating Back-lit LCD for monitoring and control. RMUPS has a fully rotating back-lit LCD (which shows load, voltage, temperature etc) which is simply twisted to be the right way up. This makes the UPS much more user friendly, especially if it's in a poorly lit room (i.e. during power failure conditions).

Load Segment Control. To extend runtime it is possible to select a load segment control function from the front panel, which will shut down a non-critical output of the UPS (on mains fail or low battery) to extend the runtime on the critical output. This feature is available from 2500VA to 3000VA.

2. Storage & Unpacking

2.1. Boxes supplied

The RMUPS series of UPS upto 6kVA can be supplied in a number of boxes (even if only one UPS has been ordered) dependant on the model required. The number of boxes should be as below;

Number of boxes supplied;

Unit	Battery module	Number of boxes (Shipped as one unit)
RMUPS1000	n/a (internal battery pack)	1 box required
RMUPS1500	n/a (internal battery pack)	1 box required
RMUPS2500	1 battery module	2 boxes required
RMUPS3000	1 battery module	2 boxes required
RMUPS4000	2 battery modules	3 boxes required
RMUPS5000	2 battery modules	3 boxes required
RMUPS6000	2 battery modules	3 boxes required

If there are not enough boxes to make up the UPS please contact order point immediately.

This is clarified in the drawings below;



RMUPS1000/RMUPS1500 UPS uses one standard battery pack behind the panel on the left-hand side of the unit. It is shipped as one box.



RMUPS2500/RMUPS3000 UPS uses two standard battery packs housed in one battery module. This is shipped as a separate box to the electronics module which sits on top of the battery module. RMUPS2500/RMUPS3000 ships as two boxes

Storage and Unpacking



RMUPS4000 to RMUPS6000 UPS uses two battery modules (containing in total four standard battery packs). The UPS electronics module ships as one box, and each battery module ships as a separate box. RMUPS4000 to RMUPS6000 ships as 3 separate boxes.

2.2. Box contents

The UPS comes complete with all cables required for operation, and is also shipped with software and racking ears for 19" shelf mounting. A full list of the box contents is provided below;

RMUPS1000/1500

1 box contains

UPS module with fitted batt.
Input cables x 1

REPO connector
RS232 cable
Software CD
Manual
Mounting feet
19" Ears (+ screws)

RMUPS2500/3000

2 boxes contain

Box 1:

UPS electronics module
Input cable x 1
output cable x 2
REPO connector
RS232 Cable
Software CD
19" rack ears (+ screws)

Box 2:

Battery module
Battery connection cable
Installation sheet
19" rack ears (+ screws)
1 set of key lock bolts

Storage and Unpacking

2.2. Box contents cont....

RMUPS4000/5000/6000

3 boxes contain

Box 1:

UPS Electronics module
REPO connector
RS232 Cable
Software CD
Manual
19" rack ears (+screws)

Box 2:

Battery module
Battery connection cable
19" rack ears (+screws)
1 set key lock bolts

Box 3:

Battery module
Battery connection cable
19" rack ears (+screws)
1 set key lock bolts

3. Installation and Set-up

3.1. Environment and Positioning

When locating the UPS system, the following points should be remembered;

- Avoid temperature and humidity extremes. To maximise the life time of the batteries an ambient temperature of 15°C to 25°C is recommended.
- Provide shelter from moisture
- Make sure that ventilation and space requirements are met.
- Maintain clearance at front of UPS for user operations
- Ensure that the air vents at the front and rear are not blocked

3.2. Free-standing configuration

When using the UPS free-standing, the unit should be mechanical stood vertically. As shown below;



RMUPS1000/1500 Free standing

RMUPS2500/3000 Free standing



RMUPS4000/5000/6000 Free standing

Installation and Set-up

3.2. Free Standing configuration cont....

The RMUPS1000/RMUPS1500 are provided with additional feet to ensure stability if free standing.

The RMUPS2500/RMUPS3000 are provided with key hole fixings to “lock” units together when located beside each other in free standing mode. This key lock function is also available as standard if additional battery packs are added to either RMUPS1000/RMUPS1500 or RMUPS2500/RMUPS3000.

The RMUPS4000/RMUPS5000/RMUPS6000 key lock together in the same way as the RMUPS2500/RMUPS3000.



The drawing above shows how to use the feet supplied as standard with the RMUPS1000 & RMUPS1500, if used in free standing configuration.

Installation and Set-up

3.3. Rack-mount configuration

All RMUPS UPS are also shipped with front panel mounting ears. These allow the units to be used in rack mount/stack orientation as shown below.



RMUPS1000/1500 Rack mount

RMUPS2500/3000 Rack Mount



RMUPS4000/5000/6000 Rack mount

The ears supplied are not designed to support the weight of the UPS. The UPS must either be supported on guides or on a shelf within the 19" cabinet.

Telescopic rack guides can be supplied as an optional part code: **RMUPS RG**. Each module needs to be fitted with Telescopic guides. Therefore when ordering an RMUPS6000 with the RG option – The constructed part number should be RMUPS6000RG. This will provide 3 sets of rack guides – 1 set for the UPS module and 1 set each for the battery module.

Installation and Set-up

3.4. Rear Panel Features

Failure to insert the REPO connector into the rear of any unit will prevent it from starting.

RMUPS1000/1500

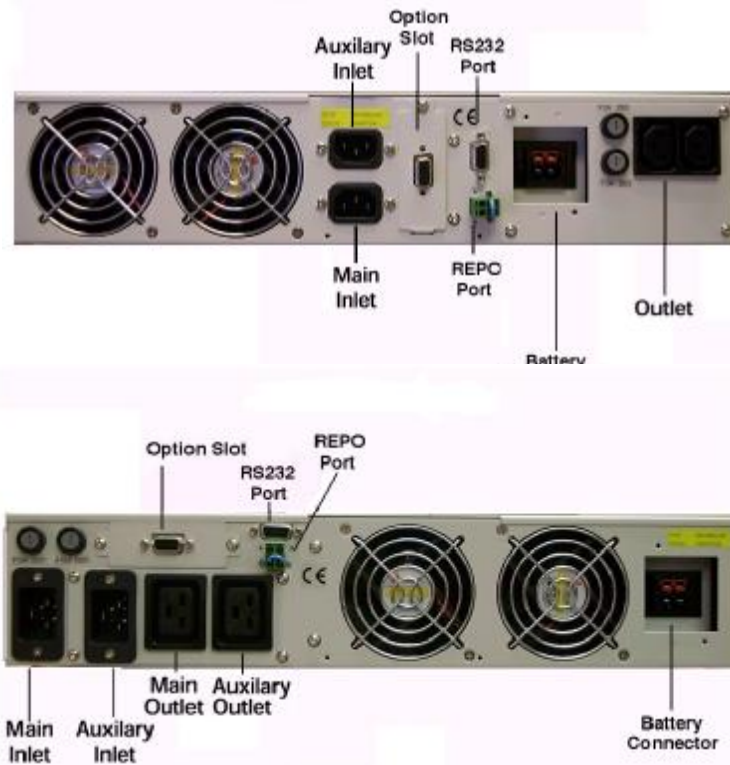

RMUPS4000/5000/6000

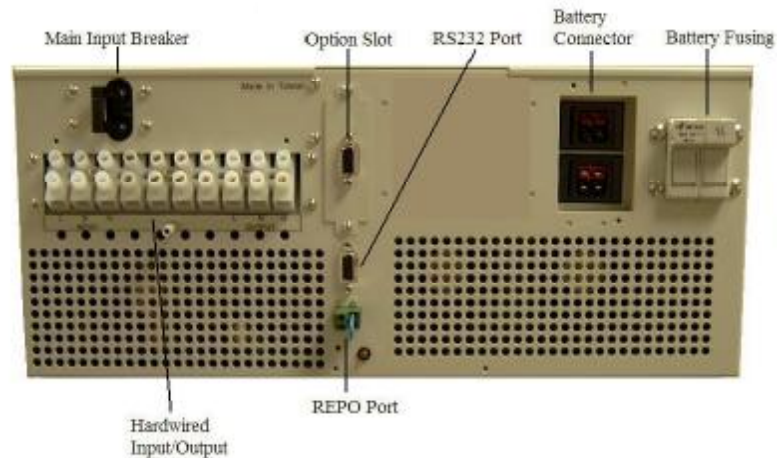

Installation and Set-up



Power cables should be connected to the utility supply. Two IEC input sockets are available: Main IEC input and Auxiliary IEC input.

If a single mains supply is available only, then the input power cord should be connected to the Main input socket. If two supplies are available then both IEC inlets can be used.

Installation and Set-up

3.6. Power connection to the RMUPS2500 & RMUPS3000

In order to connect the battery module to the UPS on the RMUPS2500 & RMUPS3000, the battery connector covers must first be removed. See diagram below;



Once this has been done the battery cable supplied can be connected between battery connector on UPS and battery connector on Battery module. The cable supplied has a simple push fit Anderson connector at each end.



When the cable has been connected the battery breaker must be switched to the "ON" position.

Installation and Set-up

3.6. Power connection to the RMUPS2500 & RMUPS3000 cont....

The input power cables can then be connected to the utility supply. Two IEC input sockets are available: Main IEC input and Auxiliary IEC input.

If a single mains supply is available only, then the input power cord should be connected to the Main input socket. If two supplies are available then both IEC inlets can be used.

Two output sockets are available from the unit: Main and load segment controlled output two. These are both 16A IEC outlets.

If load segment control is not required, then both receptacles can be used. If it is required to shutdown one output independently on mains failure or battery low, then connect to IEC outlet two.

Installation and Set-up

3.7. Power connection to the RMUPS4000 – RMUPS6000

In order to connect the battery module to the UPS on the RMUPS4000 – RMUPS6000, the battery connector cover must first be removed. See diagram below;



Once this has been done the battery cables supplied can be connected between battery connector on UPS and battery connector on each battery module. The cable supplied has a simple push fit Anderson connector at each end.



Installation and Set-up

3.7. Power connection to the RMUPS4000 – RMUPS6000 cont....

The Hardwire termination for the RMUPS4000 – RMUPS6000 provides input connection for the main supply & auxiliary supply, as well as output connection.

Connector Ratings and cable sizing;

Hardwire terminations will accept 10AWG/6mm² cable for input and output wiring.

Installation and Set-up

3.8. Communication Connectivity

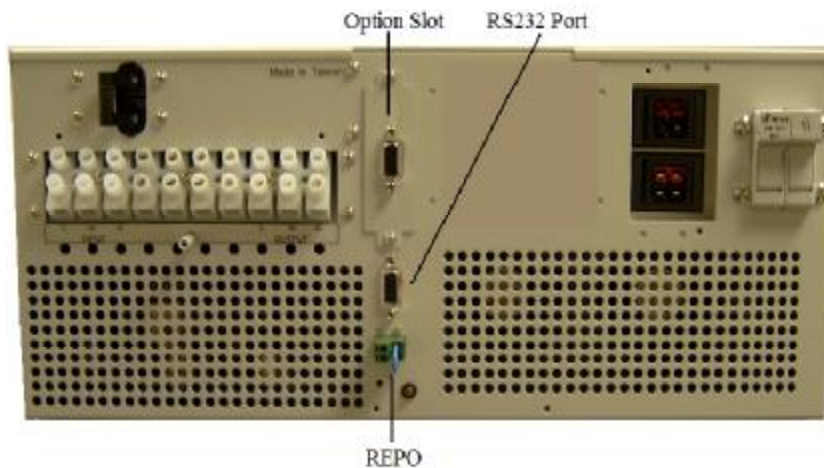
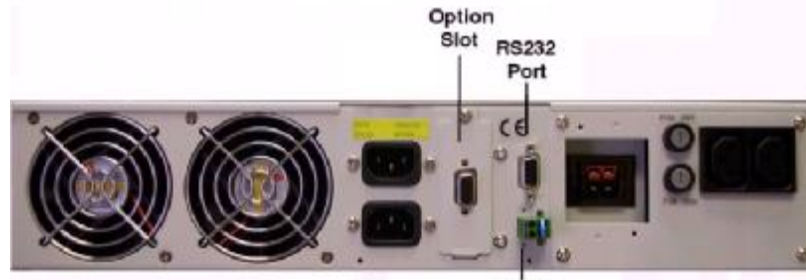

All RMUPS units are provided with the following communication ports

- Main RS232 port (fixed)
- Auxiliary RS232 port (fitted into option slot)
- REPO (remote emergency power off) port

The unit is supplied with one RS232 cable and one mating half REPO connector.

The RS232 cable will provide communications to a local computer using the supplied software package.

3.8. Communication Connectivity.....

The REPO connector can be used to shutdown the UPS from a customer-supplied switch in a remote location. See REPO operation on page 25.

The following option cards are also available (installed in place of the auxiliary RS232 port).

- Network adapter/SNMP (fits in place of the option slot RS232) – Order code **RMUPS S**
- VFC Volt free contact board (fits in place of the option slot RS232) – order code **RMUPS V**
- USB card (fits in place of the option slot RS232) – Order code **RMUPS USB**

3.8. RS232 detail

Main RS232 pin details

DB-9 Pins of the connector are as following figure:

PIN#	PIN Definition(UPS)	PIN Definition(PC)
2	Transmitted data	Received data
3	Received data	Transmitted data
4	DTE Ready	DTE Ready
5	Signal Ground	Signal Ground

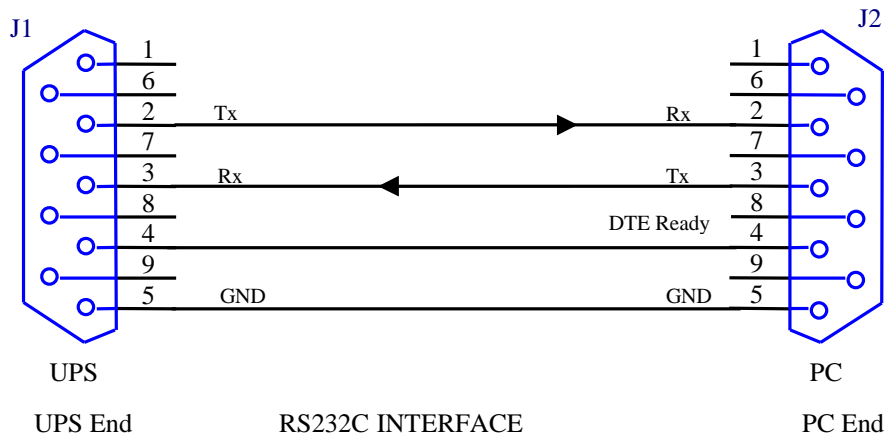

Installation and Set-up

3.8. Communication Connectivity.....

Option Slot RS232 pin* details

Pin out for the second RS232 port is as standard the same as the first. However, this can be changed to the format as shown below by removing the card and setting the 4 jumpers on the card to Megatec position (from the PC position). This should only be done when UPS is off.

The RS232 interface shall be set as follows:

Baud Rate	: 2400 bps
Data Length	: 8 bits
Stop Bit	: 1 bit
Parity	: None

The Pin Assignments of true RS232 type are illustrated as follows:

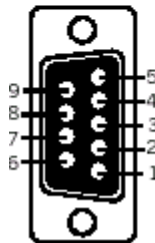

Pin 6: RS232 Rx
Pin 9: RS232 Tx
Pin 7: Ground

Installation and Set-up

3.9. REPO Configuration

The REPO connector ships as standard with a wire link to make the connection between the pins which allows the UPS to operate with no additional wiring for applications where REPO is not required. For applications where REPO is required, use the following procedure.

Operating the REPO

The REPO feature shuts down the protected equipment immediately and does not follow the orderly shutdown procedure initiated by any power management software.

Any devices which are operating on battery are also shut down immediately. When the REPO switch is closed, the equipment will not return to battery power until the UPS input is re-cycled.

This can be done by shutting down the UPS and re-starting it.

Installation and Set-up

Use the following method to install REPO switch;

- Verify that the UPS is off and unplugged
- Remove the REPO connector from the rear of the UPS
- Connect isolated, normally closed, dry contacts (rated at 60Vdc maximum, 30Vac RMS maximum and 20mA maximum), between pins 1 and 2 as shown below;

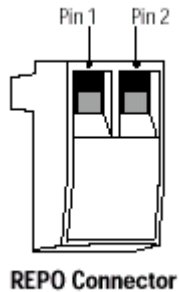

- Use stranded, non-shielded wiring – size 18 – 22 AWG.
- Replace the REPO connector into rear of UPS
- Verify that the externally connected REPO switch is off, to enable power to the UPS output receptacles.
- Plug in the UPS and start the UPS by pressing the input breaker to “ON”
- Turn on the external REPO switch to test REPO function
- Turn off REPO switch and restart UPS for normal operation.

4. Operation

4.1. Description of front panel features

The diagram/table below show the basic functions of the front panel on all RMUPS units.

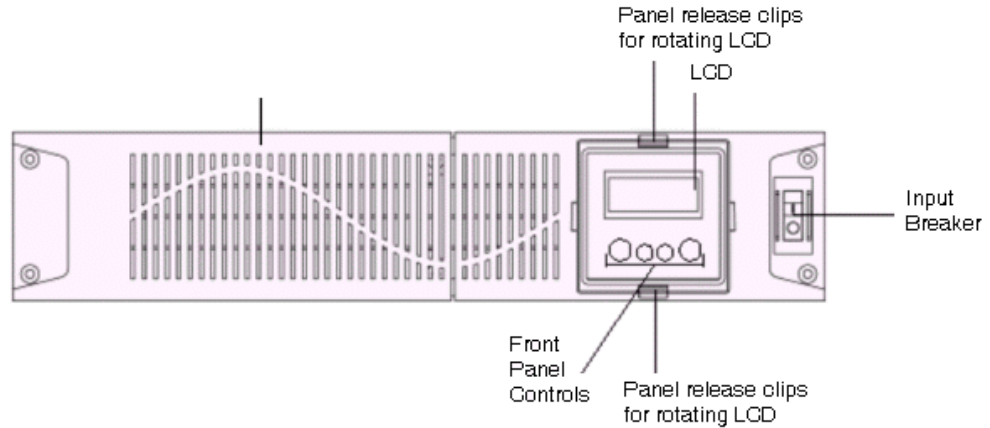

The front panel can be rotated for the correct orientation depending upon intended orientation during use, using the top and bottom clip as shown above. A Retaining screw is then used to fix the panel in place. *

*Never rotate panel whilst UPS is on

Front Panel Buttons



Turn on/off the inverter or force unit to bypass
Start UPS from battery when mains is not available

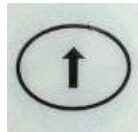

Select the status shown in the first row or move forward to next function or parameter.



Select the status shown on the second row or setting the function or parameter.

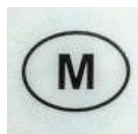

Enter the edit mode

Operation

4.2. Starting the UPS

To power up the UPS switch the input breaker on the front panel (rear panel for RMUPS4000/RMUPS5000 & RMUPS60000) to “ON” position. The LCD should show the model number.

The UPS should then beep and cycle through its start-up procedure. Once the UPS powers up and self-check is successful, then power will be supplied to the output receptacles.



The default indication at this stage on the UPS display should be;



Operation

The UPS will always show the mode of operation of the top line of the display unless the up arrow is pressed – the top line will then show the desired measurement. As soon as the UPS changes mode – it will revert to mode display. The display modes are;

Start up
AC Mode
DC Mode
Bypass Mode

The unit is now running and supplying power to the load.

4.3. Shutting down the UPS

To shut down the UPS locally (without the use of network adapters or software);

Ensure that any equipment running from the UPS has been shutdown – such that no data is lost when unit is switched off.

Push and hold the  until the UPS beeps.

The UPS is now in bypass mode and running from mains input.

Now turn the input breaker to the “OFF” position – this will cut the power to the UPS – thus shutting the UPS down.

If this shutdown is over an extended period of time (weeks), then the battery breaker should also be switched to the “OFF” position. This is also true if the UPS is being re-located.

Bypass conditions

Under normal conditions the UPS will as default operate in On line mode. That is to say that the UPS continuously operates from its Inverter (unless Green mode is selected and load is less than 5%).

The UPS will go into bypass mode if the following occurs;

- The UPS is overloaded greater than 150% (Dependant on load type) – the Bypass mode will automatically switch back to running from Inverter in less than 1 minute after overload

is removed. (If overload is greater than 180-200% (dependant on load type) then the UPS will remain in bypass until manually restored to Inverter by the button. The UPS size used needs to be reviewed.

- If the UPS decides that a fault will not allow it to operate from Inverter. This condition cannot be reset – please contact your Black Box.
- If the UPS is forced to bypass as described in 4.2.











In any case the user can identify if the UPS goes into bypass by the beep that is made – and when in bypass the UPS displays **Bypass Mode** on the top line of the LCD display.

Operation





4.4. Using the front panel

Accessing the menu functions from the front panel allows the user to confirm a number of parameters and measurements through the UPS system.

To control what is displayed on the top line of the display;

1 st press		Top line: Bottom line:	
2 nd press		Top line: Bottom line:	
3 rd press		Top line: Bottom line:	
4 th press		Top line: Bottom line:	
5 th press		Top line: Bottom line:	

Operation

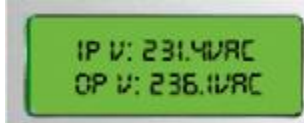
6 th press		Top line: Bottom line:	
7 th press		Top line: Bottom Line:	
8 th press		Return to start	

The bottom line of the display can also be used to display these parameters whilst leaving the top line fixed on one parameter, by pressing



There are nine display parameters available using the above method as defined below;

- OP A : Output current
- IP V : Input Voltage
- OP V : Output Voltage
- OP F : Output Frequency
- BT V : Battery Voltage
- Load : percent of Load
- T. EN: temperature of environment
- T. HS : temperature of the internal heat sink

The button used to edit the parameters within the UPS is



Use the



key to enter edit mode of the UPS.

Functions and parameters can be set using



key for moving between different parameters.

Operation

4.4. Using the front panel cont....

Then use  key for selecting that parameter.

Example;

To set the Buzzer to normal mode (i.e. buzzer will sound);

Press  Twice which takes the display to Buzzer configuration.

The press  until display shows;



The press  to store setting.

Buzzer silent mode is now disabled.

Using the  button.

1st press: Green Mode



EN: Enable Green Mode.
DIS: Disable Green Mode.

Green mode allows the user to set the unit to run directly from the mains when the load is less than 5%. If the load increases then the unit will switch back to On line mode.

This improves efficiency under low load running conditions.

2nd press: Buzzer Silent*
(see example page 30)



EN: Enable the Buzzer Silent function.
DIS: Disable the Buzzer Silent function.

* The Buzzer will not be silenced under Low Battery conditions.

Operation

3rd press: Output Voltage*



To change from 208VAC to 230VAC press the repeatedly until the displays shows the arrow Against 230VAC.



Then press the



to set the mode

* After choosing the desired output voltage, the UPS needs to shutdown completely and re-started to activate the selection

4th press: Test Mode :



Press the



key for testing the UPS/battery.

The display will show "test fail" if the UPS/Battery is found to be faulty. The battery will need replacing urgently – the UPS may not be able to support the load under mains fail conditions.

5th press: Load Segment Control:



LB : Load Control active when Low Battery.

LV : Load Control active when Line Voltage Fail.

DIS : Disable the Load Control function

Note: The display remains on the selected Menu function for 5 seconds only and then reverts to the default display condition.

Operation

4.5. Audible Alarms

The UPS provides an overview of the alarm/alert functions via the audible alarm produced.

These can also form part of the trouble-shooting guide – see page 36

Audible Alarms

- Battery Mode (DC Mode)
____ . _____
- Battery Low
____ . ____ . _____ . _____ . _____
- Line Voltage fault
_____ . _____ . _____
- Line Frequency fault
__ . __ . __ . __
- Over Temperature
__ . __ . __ . __ . __
- Input Over Current
__ . __ . __ . __ . __ . __
- Overload or UPS Fault
_____ .
- Charger Fault
____ . _____ . _____ .

Key

- _____ Buzzer On
- . Buzzer Off

Operation

4.6. On mains operation

During normal “On Mains Operation”, the UPS should display it’s default screen which will show “AC Mode” on the top line and the output voltage on the bottom line (unless changed by the user);

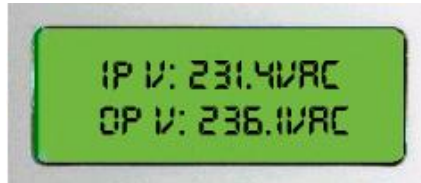

Input and Output voltages will change dependant on the UPS location a settings.

The UPS should make no audible alarm noise.

This then indicates that power is being supplied to the load and the system is functioning normally.

If a further test is required then use the self-test function to check the UPS operation. See “using the front panel” on page 21.

Operation

4.7. On battery operation

The UPS will go to battery mode when one of the following conditions occurs;

- Mains input (both main and auxiliary) has failed
- Mains input (both main and auxiliary) is out of specified input parameters i.e.
 - Exceeds or is lower than specified input voltage range
 - Exceeds or is lower than specified input frequency range

The default display will be “DC Mode” on the top line and output voltage on the bottom line (if mains has failed);

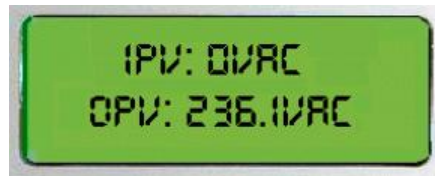

OPV may vary dependant on settings.

The unit will emit the following Audible alarms;

- Utility out of specification: two short beeps repeating
- Battery low (at end of discharge): short beep repeating

5. Trouble Shooting

5.1. Basic trouble shooting

Problem & Possible Cause	Solution
UPS will not turn on	
<p>REPO active</p> <p>Input breaker not switched on</p> <p>UPS input cct breaker may have tripped</p> <p>Input/battery cables not correctly fitted</p> <p>The UPS reports a code at start up</p>	<p>Ensure REPO is connected and external switch is reset</p> <p>Ensure that UPS input breaker on front panel has been switched to "ON" position</p> <p>Ensure that the load on the UPS is less than the rating label power stated. The UPS may have overloaded.</p> <p>Ensure that input cables and battery cables are securely fitted into the UPS and battery pack. Check battery breaker is switched to "ON" position</p> <p>See code descriptions in "LCD trouble Shooting guide"</p>
UPS will not provide power to the load	
<p>Power only present on one output receptacle</p> <p>No output from output cable</p> <p>Output fails as soon as load connected</p>	<p>If 2.5kVA or 3kVA unit – check load Segment control setting. See page 24</p> <p>Check cable is correctly installed into rear of UPS.</p> <p>make sure that load does not exceed Maximum rating of UPS</p>
UPS operates from battery despite mains being available.	
<p>Check fusing</p> <p>Input voltage out of tolerance</p> <p>Auxiliary mains input not working</p> <p>Generator does not seem to power UPS, without UPS going to battery</p>	<p>Input fuse may need replacing</p> <p>Check LCD reading of input voltage - it must be within specified limits of voltage and frequency – specification section 7.</p> <p>Check that Auxiliary supply is plugged in at Source.</p> <p>Check generator is properly governed for both frequency and voltage. Some low Grade generators will not supply a stable Enough supply to run an UPS</p>

Trouble Shooting

5.1. Basic trouble shooting cont....

<p>UPS drops the load when it should Go onto battery</p>	
<p>When power fails the UPS drops the load When it should have gone into battery mode</p> <p>The UPS beeps</p>	<p>The UPS was in bypass, probably because of overload - check the load status - see page 28</p> <p>See Audible alarm status page 32</p>
<p>UPS battery time not long enough or unit does not run on battery at all</p>	
<p>UPS works on battery, but required back up time is not as long as was Expected</p>	<p>Check to see if batteries are ok - use "test" function as described on page 24. If battery reported faulty - see changing the battery in maintenance section 5.2</p> <p>Check to see load has not increased - this will reduce run time available from battery</p> <p>Shed non-critical load when mains fails. Use load segment function which allows the user to switch off non critical items of load on mains failure or battery low</p>
<p>UPS Beeping</p>	
<p>The UPS is beeping and I don't know why?</p>	<p>See the notes on page 33</p>
<p>Cannot see my UPS remotely/via RS232</p>	
<p>I cannot see the UPS via my RS232 or Network adapter card?</p>	<p>Check RS232/SNMP card connections on rear of UPS.</p> <p>Read the manuals that come with the options cards (within option card box) or see the software section in this manual (software manual also on CD enc.)</p>

Trouble Shooting

5.2. LCD trouble shooting

The following fault conditions displayed on the panel can be read as follows;

The DC bus voltage exceeds high set point – contact Point of sale.



The DC bus is out of specified limits – contact point of sale.



Inverter voltage over high set point – contact point of sale.



Inverter voltage under low set point – contact point of sale.



Trouble Shooting

5.2. LCD Trouble shooting cont....

Output current over high set point – Check UPS for overload



Battery Voltage under low set point – UPS battery low/faulty



DC Bus voltage under low set point – contact point of sale



Inverter frequency error – contact point of sale



Trouble Shooting

5.3. Replacing batteries

RMUPS1000 & RMUPS1500

Replacing batteries on the RMUPS1000 & RMUPS1500 should be carried out as follows;

Remove fascia panel from left hand/bottom (dependent on orientation of the unit as indicated below);

FixingScrews

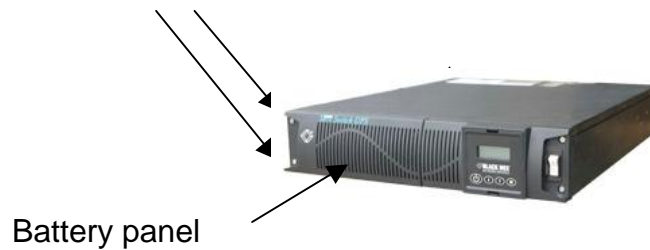

This can be done by removing two fixing screws as indicated.

Once this panel has been removed, the retaining plate needs to be unscrewed and removed before access is available to the battery pack.

The battery pack can then be simply withdrawn as shown below;

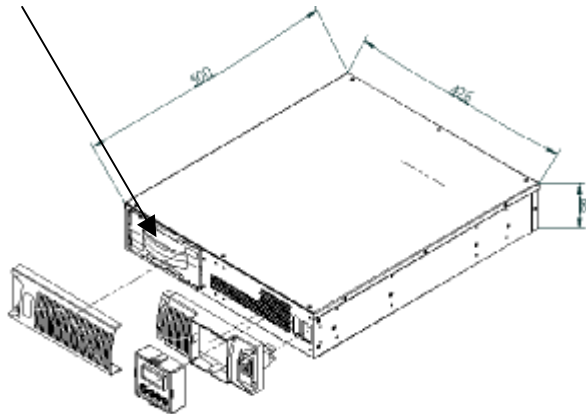

It is only necessary to remove the battery panel, (this drawing shows general assembly of the entire front panel)

Warning: Removing the battery whilst the unit is supporting load could result in loss of power to load if mains fails during replacement.

Trouble Shooting

5.3. Replacing the batteries cont...

RMUPS2500 – RMUPS6000

The RMUPS2500/RMUPS3000 ships with one battery module & the RMUPS4000/RMUPS5000 & RMUPS6000 ships with two battery modules.

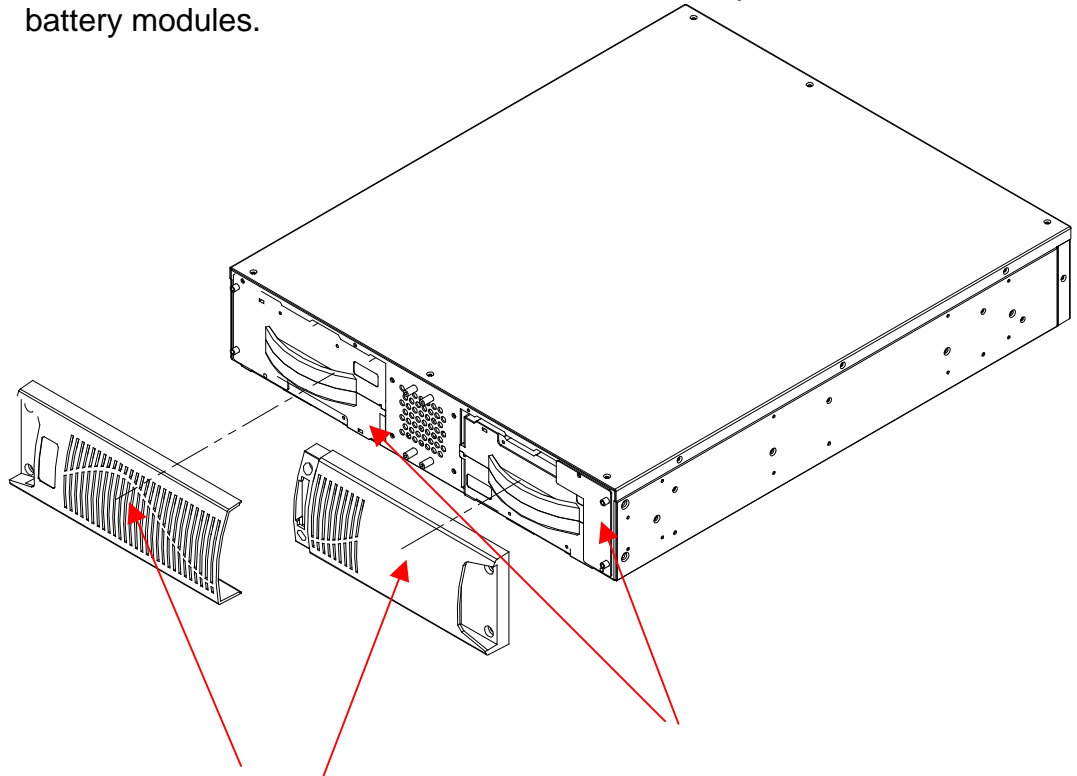

Front Panels

Retaining plates

First remove both front panels as shown above. Then remove both retaining plates to gain access to the battery packs.

Battery packs can then be withdrawn using the handles provided and replacement packs can be fitted. Battery modules can be isolated from UPS if required by switching off the battery breaker on the rear of the battery module.

Warning: Removing the battery whilst the unit is supporting load could result in loss of power to load if mains fails during battery replacement.

Number of battery packs required;

RMUPS1000 & RMUPS1500 will need 1 pack (unless separate battery modules are fitted)

RMUPS2500 & RMUPS3000 will need 2 packs (per module)

RMUPS4000 – RMUPS6000 will need 4 packs (2 modules)

Spare battery packs are available under order code: **RMUPS BP**

6. Specification

6.1. General specification

Input:

Input Voltage: 176-276 VAC full load, 125-276 VAC 25% load, without using battery.
Input Frequency: 50/60 Hz autosensing (45-65 Hz).
Input Power Factor: >0.98 at full load.
Crest factor: 3:1
Input Protection: Fuse/breaker.

Output:

Output Voltage: 208/220/230/240 VAC selectable via front panel LCD.
Output Regulation: $\pm 2\%$ of nominal.
Output Waveform: Sine wave.
Output THD: < 3%.
Output Protection: Electronic

overload sensing.
Efficiency (AC-AC): 87% up to 1.5 kVA, 90% up to 6 kVA.
Overload Capacity: 105% for 120 secs, 150% for 10 secs.
Output Frequency: 50/60 Hz autosensing to input.

General: Input Receptacles: 2 x IEC320-10A ≤ 1.5 kVA, 2 x IEC320-16A 2.5 kVA to 3 kVA, Hardwired 4 kVA to 6 kVA, Dual feed.
Output Receptacles: 2 x IEC320-10A ≤ 1.5 kVA, 2 x IEC320-16A 2.5 kVA to 3 kVA, Hardwired 4 to 6 kVA, Load segment control via LCD 2.5 kVA & above.
display/Alarm: Front panel LCD menu driven, audible alarms.
Interface: 2 x RS232 (Rear Panel),

option slot for SNMP/USB of VFC.
Software: Supplied bundled to support Windows 95, 98, Me, 2000, XP & NT, & Novell.

Environmental: Operating Temperature: 0 °C to + 40 °C.
Storage Temperature: -15 °C to +50 °C.
Relative Humidity: 0-95% RH non-condensing.
Altitude: 3000m without derating.
Acoustic Noise: <45 dBA at 1 metre.

Battery: Internal Battery Type: VRLA
5 year design life, 10 year option add suffix "X" to model number.
Battery Replacement: Hot swap all models.
Recharge: <4 hours to 90%,

standard battery only.
Battery String Voltage: 48 V up to 1.5 kVA, 96 V 2.5 kVA to 3 kVA, 192 V 4 kVA to 6 kVA.
Temperature: Autonomy, recharge & battery life based on 25 °C ambient.

E M C & Safety:

Safety: EN50091-1-1 & EN60950.
EMI: EN50091-2 Class B, EN55022B.
Immunity: IEC61000-4-2, -3, -4 & -5.
Approvals: CE, TUV/GS.
Ingress Rating: IP20.

Specification

6.2. Run time chart

	200VA/140w	400VA/280w	600VA/420w	800VA/560w	1000VA/700w	1500VA/1050w	2000VA/1400w	2500VA/1750w	3000VA/2100w	4000VA/2800w	5000VA/3500w	6000VA/4200w
RMUPS1000	59	32	18	12	8							
+1BM	260	134	93	58	50							
+2BM	466	247	166	124	91							
+3BM		358	250	183	146							
RMUPS1500	63	34	19	13	9	5						
+1BM	274	142	88	62	53	31						
+2BM	491	260	175	131	96	60						
+3BM		377	264	193	154	92						
RMUPS2500	167	85	59	47	34	15	9	6				
+1BM	371	212	152	107	78	46	29	20				
+2BM	589	337	244	179	144	66	54	41				
+3BM		478	334	255	198	104	68	58				
RMUPS3000	140	66	51	38	26	15	10	6	5			
+1BM	313	175	121	88	63	46	29	21	16			
+2BM		285	196	153	118	67	54	42	31			
+3BM		391	280	211	169	106	69	59	49			
RMUPS4000		130	88	63	54	37	23	16	13	8		
+2BM		290	214	166	137	84	57	50	40	26		
+4BM		467	339	269	221	149	104	76	60	48		
+6BM			479	374	305	208	151	119	93	61		
RMUPS5000		133	90	65	56	38	24	17	13	8	6	
+2BM		297	219	170	140	86	59	51	41	26	19	
+4BM		477	346	275	226	152	106	78	61	49	37	
+6BM			489	382	311	212	154	121	96	62	54	
RMUPS6000		140	95	68	59	40	25	18	14	9	6	5
+2BM		313	231	179	148	91	62	54	44	28	20	15
+4BM		503	365	290	238	161	112	82	65	52	39	28
+6BM			515	403	328	224	163	128	101	66	57	46

For extended run times (above and beyond those shown here), please contact point of sale.

Specification

6.3. Fixing centres and Dimension tables

Rack mount Fixing centres for Guides (RMUPS R)

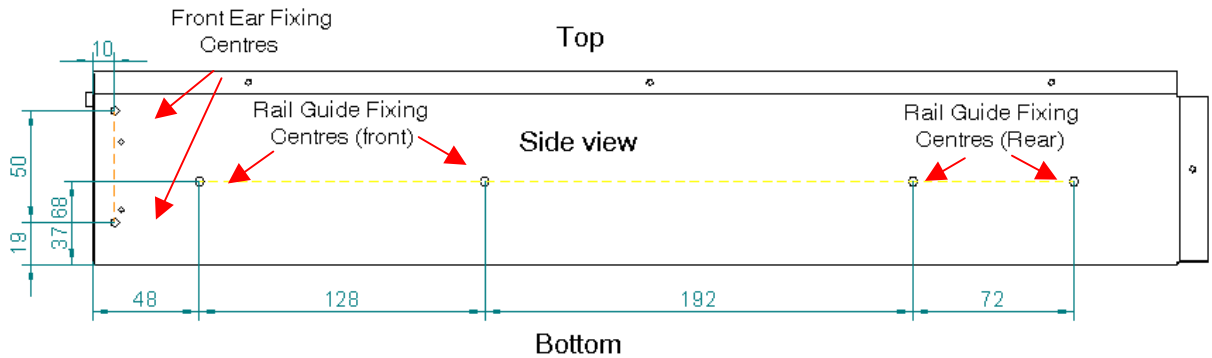

RMUPS Dimensions

Model	Height (mm U)	Depth (mm)	Width (mm)
RMUPS1000	88.9 2U	510	426
RMUPS1500	88.9 2U	510	426
RMUPS2500	177.8 4U	510	426
RMUPS3000	177.8 4U	510	426
RMUPS4000	355.6 8U	510	426
RMUPS5000	355.6 8U	510	426
RMUPS6000	355.6 8U	510	426
RMUPSBM	88.9 2U	510	426

RMUPS Weights

Model	Weight (kg)
RMUPS1000	22
RMUPS1500	22
RMUPS2500	20 + 28
RMUPS3000	20 + 28
RMUPS4000	20 + 28 + 28
RMUPS5000	20 + 28 + 28
RMUPS6000	20 + 28 + 28
RMUPSBM	28

7. Contact Information

UK 0044 1189 655000

Black Box Network Services
464 Basingstoke Road
Reading
Berkshire
RG2 0BG

Austria

Black Box GmbH
Obachgasse 26
Wien
1220

Belgium 0032 2717 2192

Black Box Network Services
Ikarooslaan 69
Zaventem
1930

Denmark 0045 5663 3010

Black Box A/S
Tigervej 12
Koge
94563

Finland 0201 888 888

Black Box Finland OY
Mikkolante 20
Helsinki
00640

France

Silic 195
46 Rue de la Couture
Rungis
94563

Germany 0049 811 55410

Black Box Deutschland
Ludwigstarsse 45
Hellbergmoos
85399

Italy

Black Box Italia Srl
Viale delle industrie II
PI 02070860966
Vimadrone
20090

Netherlands

Black Box
Savannahweg 59
Utrecht
3542

Norway 0047 55 300 700

Black Box Norge AG
Damsgardsveien
106, 5 etg

Spain

Black Box Comunicaciones SA
C/Gomera 10
San Sebastian De Los Reyes

Sweden 0046 844 55 870

Black Box Sverige
Maltesholmvagen 138
Hasselby
16516

Switzerland 0041 61 385 3535

Black Box Network Services AG
Zurchstrasse 102
Altendorf
8852

8. Index

A

Alarm Conditions – see trouble shooting
VFC – 23
Audible Alarms – 39
Auxiliary Outlet – 21
Auxiliary Supply – 11, 12

B

Batteries
 Battery cct breaker – 23
 Battery Runtime chart – 49
 Battery replacing – 46-47
 Battery Installation – 23
 Battery storage – 18
 Battery disposal – 4
 Battery Mode- 40
 Battery start mode – 33
Block diagram – 11
Boost Converter – 11, 12
Buzzer Silent – 37
Bypass – 11, 12

C

Charger – 11, 12
Communications Connectivity – 27
Contact Information – 53

D

Dual Mains Input – 13
Dimensional Drawings – 52-53

Index

E

Edit Mode – 36
Emergency Power Off – 30
Environment – 18
Environment Temperature - 36

F

Force to Bypass – 34
Free Standing mode – 18
Front Panel – 32- 41

G

Generator – 42
Green Mode – 37

I

Input Breaker – 32, 42
Inverter – 11, 12

L

Load Segment Control – 38
Low Battery – 38, 39, 41

N

Network adapter – 28

Index

O

On Mains Operation – 40
On Battery Operation – 41
On-Line – 11, 12
Output Voltage Configuration – 38
Overload 11

P

Positioning – 8
Power Connection – 22-26

R

Rack Mount mode - 20
REPO – 27, 30
Rear Panel Features – 21
Rectifier – 11, 12
Replacing Batteries – 46
Retaining plates – 46
RS232 – 21, 22, 27

S

Safety – 3
Static Switch/Bypass – 11, 12, 32, 34
Starting the UPS – 33
Shutting down the UPS – 34
SNMP – 27
Specification – 48
String Voltage – 13

Index

T

Test Mode – 38
Trouble shooting – 42
Turn on UPS – 33

U

UPS function – 11
USB – 27

V

Visual fault conditions – 44-45

W

Weights - 50