

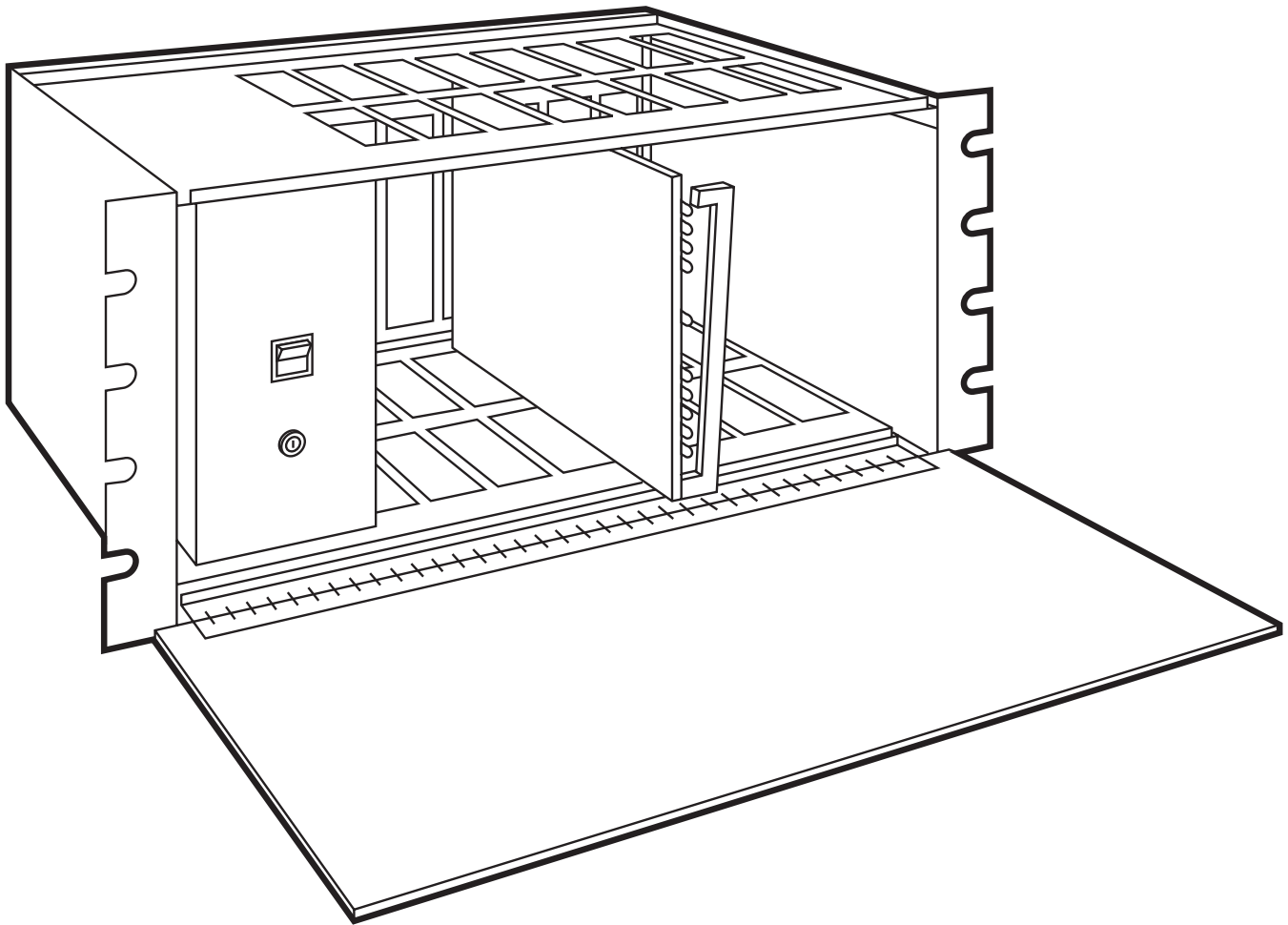

# Interface Converter Rack (8-Card)



---

**CUSTOMER  
SUPPORT  
INFORMATION**

Order **toll-free** in the U.S. 24 hours, 7 A.M. Monday to midnight Friday: **877-877-BBOX**  
FREE technical support, 24 hours a day, 7 days a week: Call **724-746-5500** or fax **724-746-0746**  
Mail order: **Black Box Corporation**, 1000 Park Drive, Lawrence, PA 15055-1018  
Web site: [www.blackbox.com](http://www.blackbox.com) • E-mail: [info@blackbox.com](mailto:info@blackbox.com)

# Contents

<b>Chapter</b>	<b>Page</b>
1. Specifications .....	3
2. Introduction .....	4
3. Installation .....	8
4. Troubleshooting .....	12
4.1 Fuses .....	12
4.2 Calling Black Box .....	12
4.3 Shipping and Packaging .....	12

# 1. Specifications

<b>Capacity</b> —	8 cards
<b>Power</b> —	Input: 115 VAC or 230 VAC $\pm 10\%$ , switch-selectable, 50/60 Hz, 2A max.; Output: 18.4 VAC center tapped, 8 amps fused at 5A
<b>Power Inlet</b> —	IEC 320
<b>Fuses</b> —	Input (Front panel): 2A, 250V slow-blow 3AG style (Buss MDL-2A, Littelfuse 313002); Output: (2) Inline F250V, 5A, 5 x 20 mm (Buss GDA-5A, Littelfuse 216005 or equivalent)
<b>Temperature</b> —	-4 to 140°F (-20 to 60°C)
<b>Humidity</b> —	Up to 95% relative, non-condensing
<b>Dimensions</b> —	8.8"H x 19"W x 12"D (22.4 x 48.3 x 30.5 cm)
<b>Weight</b> —	20.5 lb. (9.3 kg) including power supply; 10.3 lb. (4.7 kg) power supply only

## 2. Introduction

With an 8-Card Interface Converter Rack (RM060E-R2) you can install multiple cards in a standard 19-inch (48.3-cm) rack. The Rack uses a low-voltage bus to distribute power to the installed cards. Special features include a hinged front panel, easily removable power supply, combination faceplate/pulltab on each card that positively locks the card in position, and cable-support brackets supplied with certain cards to allow removal and replacement of the card without requiring the cables to be detached from the Rack.

Figure 2-1 on the next page shows the front view of the Rack, and Fig. 2-2 on page 6 shows the rear view of the Rack. Figure 2-3 on page 6 shows the top view of the Rack.

Figure 2-4 on page 7 shows the front view of the power supply alone, and Fig. 2-5 on page 7 shows the rear view of the power supply.

### **What's Included with Your Rack:**

- (1) Interface Converter Rack (8-Card)
- (4) 6 x 32 x ¼ screws
- (4) #6 lockwashers
- (2) Nylatch plungers

### **NOTE**

**The product is shipped with a standard U.S. power cord but will accept any standard IEC 320 power connection. For country-specific power cords, call Technical Support.**

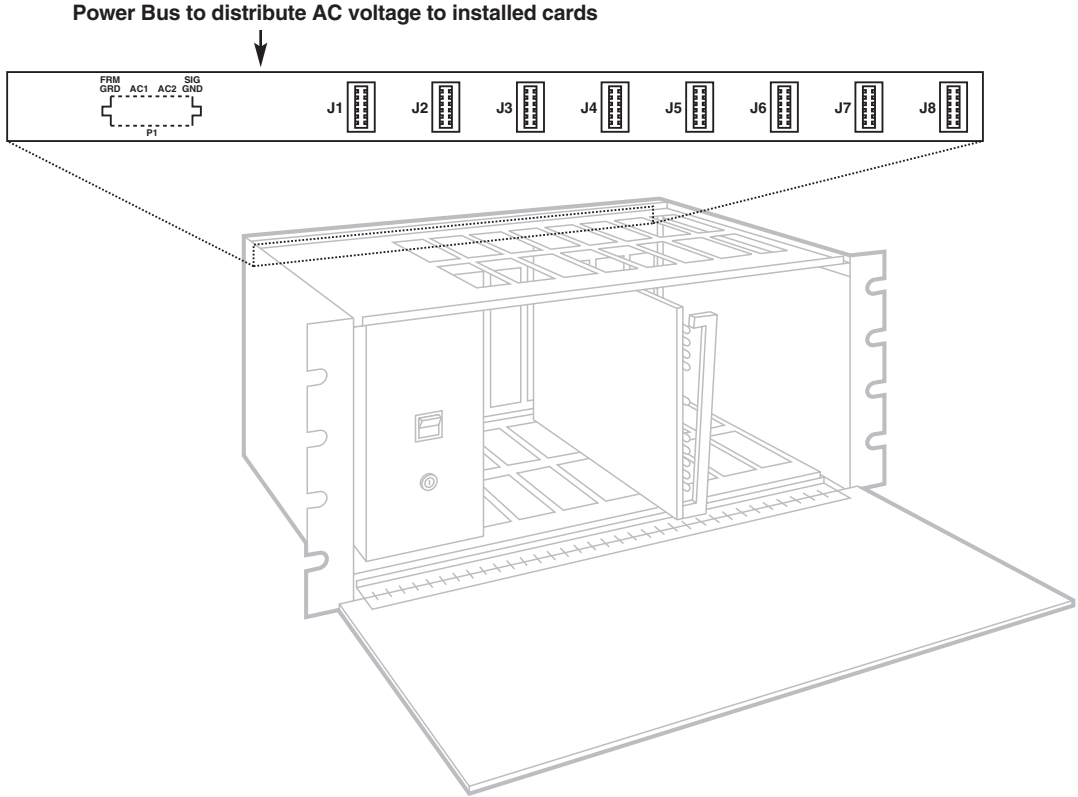

**Fig. 2-1. Front View of the Rack with Installed Cards.**

# INTERFACE CONVERTER RACK (8-CARD)

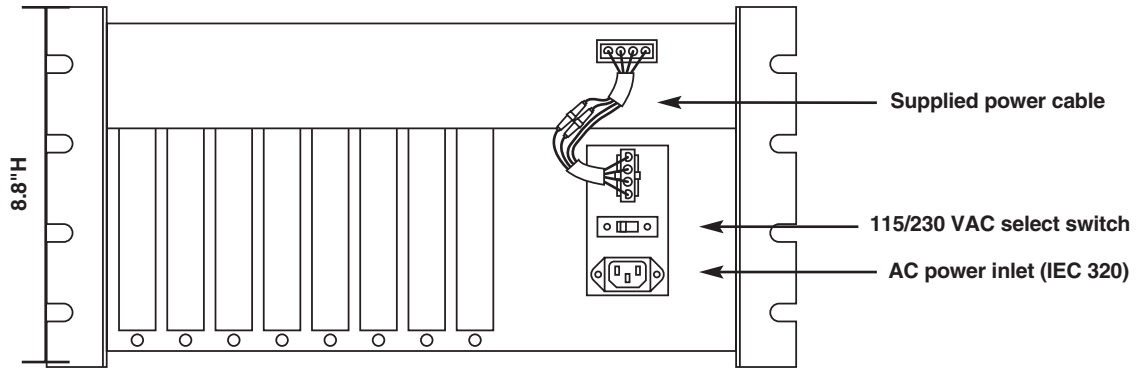

Fig. 2-2. Rear View of the Rack.

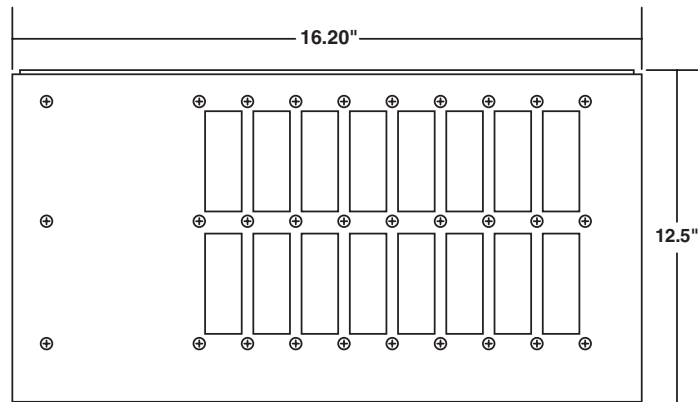

Fig. 2-3. Top View of the Rack.

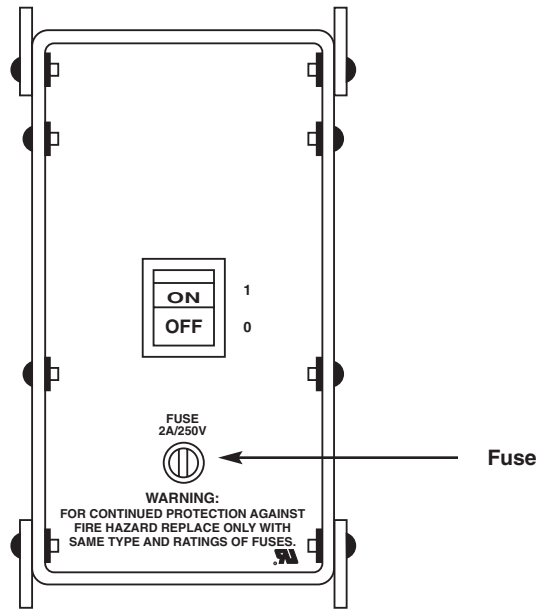

Fig. 2-4. Front View of the Rack's Power Supply, Part Number PS085-R2.

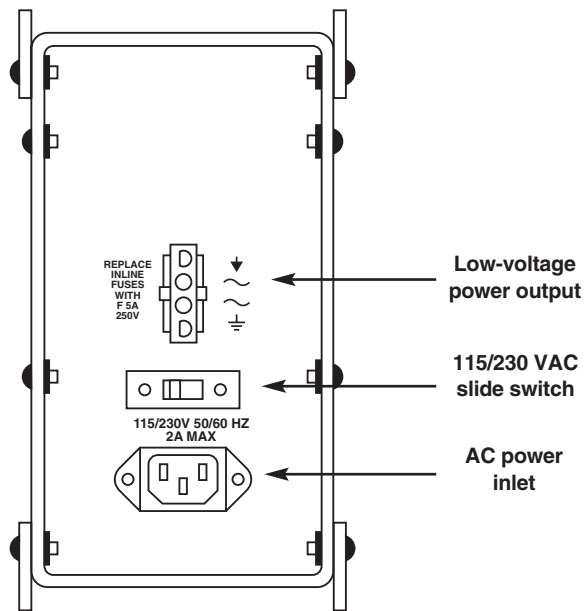
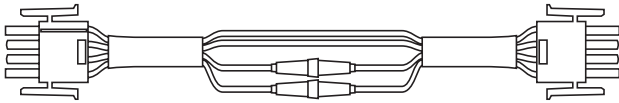

Fig. 2-5. Rear View of the RM060E-R2's Power Supply (PS085-R2).

# 3. Installation

Follow these steps to install the Rack and the cards it will contain.

1. Carefully slide the PS085-R2 into the rack guides. See Figure 2-1.
2. Secure the power supply to the Rack using all four 6 x 32 x ¼ screws and four #6 lockwashers supplied, threading the screws through the backplane of the Rack into the power supply.
3. Run the included cable (see Figure 3-1 below) from the power supply to the power-distribution bus. Refer to Fig. 2-2 on page 6.



**Fig. 3-1. Power Cable.**

4. If cable-support brackets were supplied with any of the cards you'll be installing in the Rack, attach the brackets to the back of the Rack using one 4 x 40 x ¾ screw, supplied with the cards. Do not tighten the screw completely at this time; the cable-support bracket must be able to move slightly in position. Make sure to tighten these screws after cables and cards are completely installed. See Fig. 3-2. Make sure that the screw locks are pointing out of the back of the rack, as shown in Fig. 3-3.

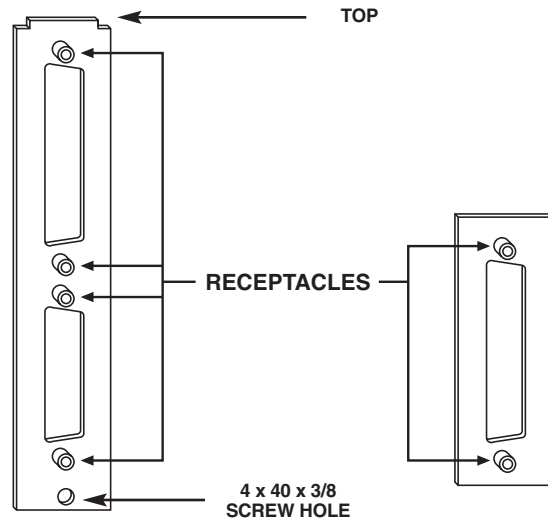

**Fig. 3-2. Cable-Support Brackets.**



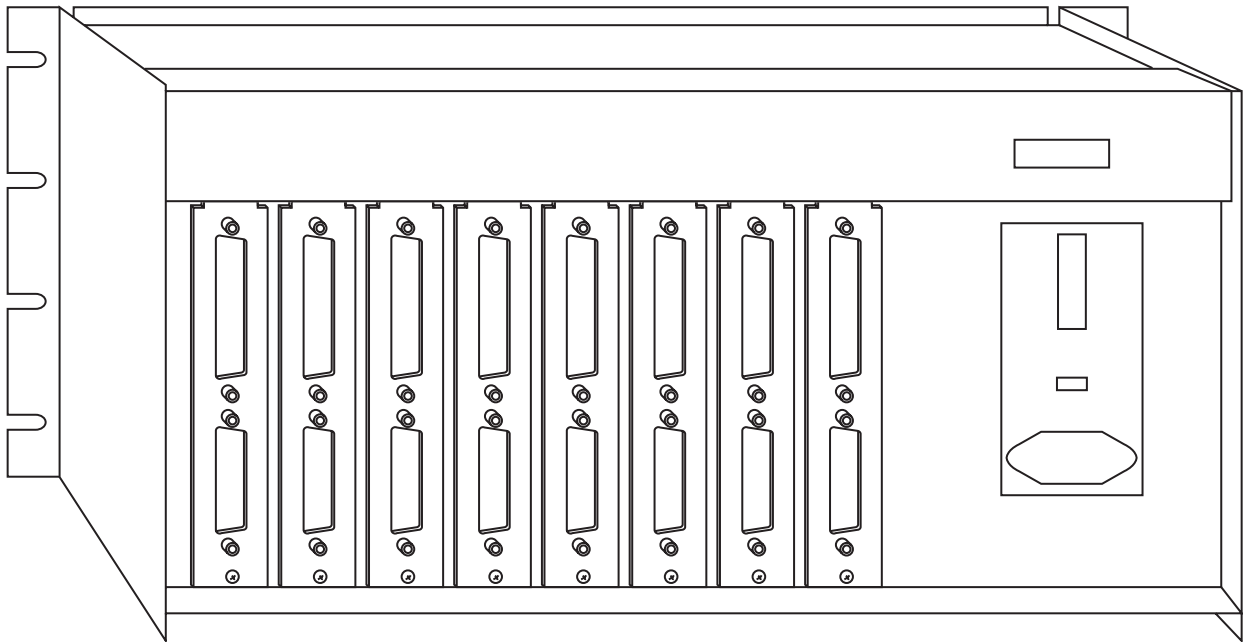
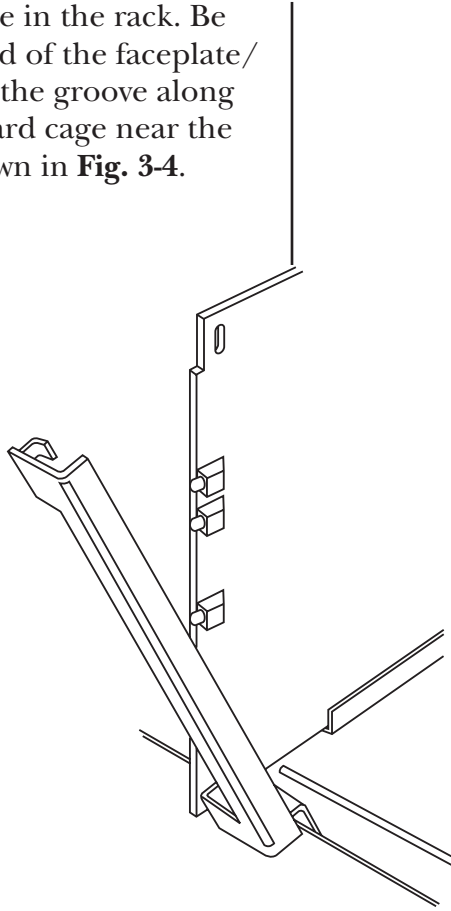

**Fig. 3-3. Back of Rack with Cable-Support Brackets Installed.**

5. Mount the Rack in your equipment bay with four standard mounting screws (not supplied).
6. Remove the female screw locks from the back of each card.

## INTERFACE CONVERTER RACK (8-CARD)

- Slide each card into place in the rack. Be certain that the lower end of the faceplate/pulltab seats properly in the groove along the front of the Rack's card cage near the front-panel hinge as shown in **Fig. 3-4**.



**Fig. 3-4. Seating the Lower End of the Faceplate in the Groove on the Bottom Front of the Rack.**

- Without bumping the card's LEDs, push the top of the lever of the locking tab on the upper end of the faceplate/pulltab into the small slot on the card as shown in **Fig. 3-5**.

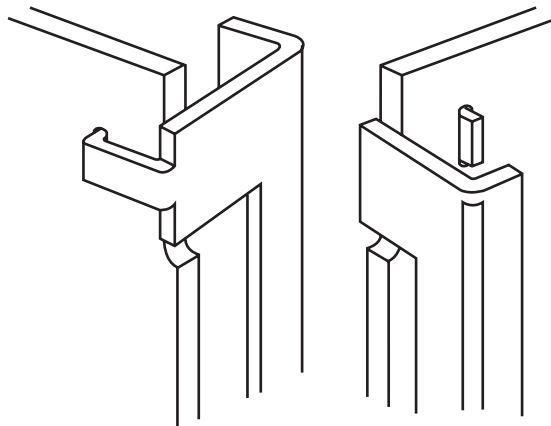

**Fig. 3-5. Placing the Top of the Faceplate in the Locking Tab.**

9. Attach your interconnect cables to the cable-support bracket and tighten the screw on the cable-support bracket securely. If the card does not come with a cable-support bracket, then attach the interconnect cables directly to the connectors on the card. **Fig. 3-6** shows the cables attached to the brackets.

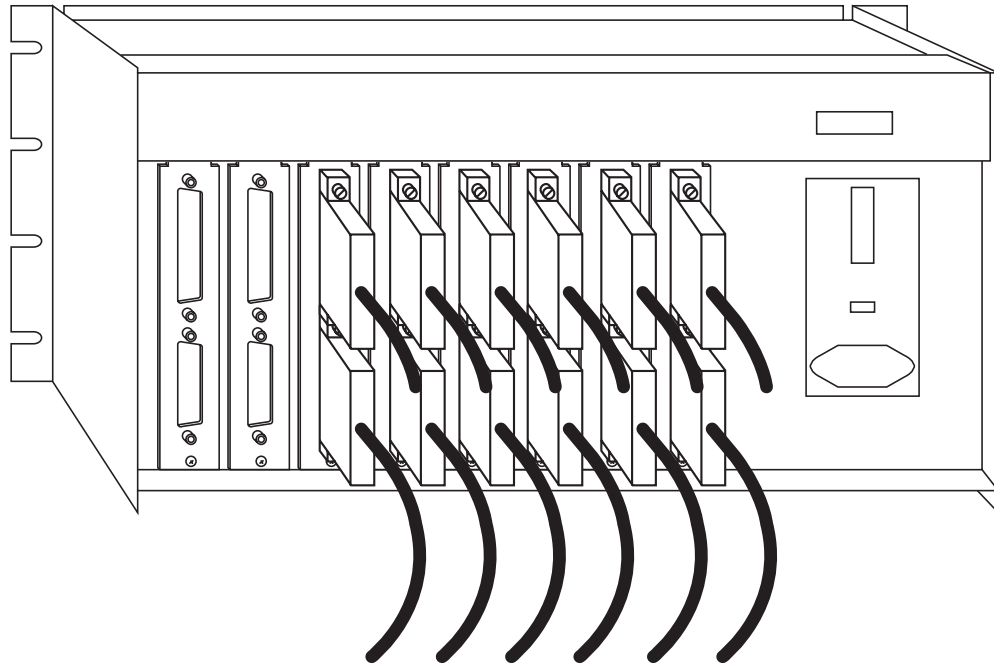

**Fig. 3-6. Back View of the Rack with the Cables Attached.**

10. **IMPORTANT:** Check the position of the voltage-selection switch on the power supply (see Figure 2-5), and set it to the proper voltage for your application. Make sure that the ON/OFF switch is in the OFF position. Connect the AC-power cord to the Rack and to an AC receptacle of the proper voltage.
11. Installation is now complete. You can power on the Rack by moving the ON/OFF switch to the ON position.

## 4. Troubleshooting

### 4.1 Fuses

If you're having problems with your rack, you'll need to check the fuses. *Before checking the fuses, remove all power to the unit—failure to do so could result in personal injury and equipment damage.* Replace fuses only with the same type and rating.

### 4.2 Calling Black Box

If you determine that your Rack is malfunctioning, *do not attempt to alter or repair the unit.* Contact Black Box Technical Support at 724-746-5500. The problem may be solvable over the phone.

Before you do, make a record of the history of the problem. We will be able to provide more efficient and accurate assistance if you have a complete description, including:

- the nature and duration of the problem.
- when the problem occurs.
- the components involved in the problem.
- any particular application that, when used, appears to create the problem or make it worse.

### 4.3 Shipping and Packaging

If you need to transport or ship your Rack:

- Package it carefully. We recommend that you use the original container.
- If you are shipping the Rack for repair, include its power supply. If you are returning the Rack, make sure you include everything you received with the unit. Before you ship, contact BlackBox to get a Return Materials Authorization (RMA) number.



© Copyright 1998. Black Box Corporation. All rights reserved.

---

1000 Park Drive • Lawrence, PA 15055-1018 • 724-746-5500 • Fax 724-746-0746