



© Copyright 2000. Black Box Corporation. All rights reserved.

1000 Park Drive • Lawrence, PA 15055-1018 • 724-746-5500 • Fax 724-746-0746



BLACK BOX[®]
NETWORK SERVICES



JULY 2000
RF311A

4-Shelf Printer Stand

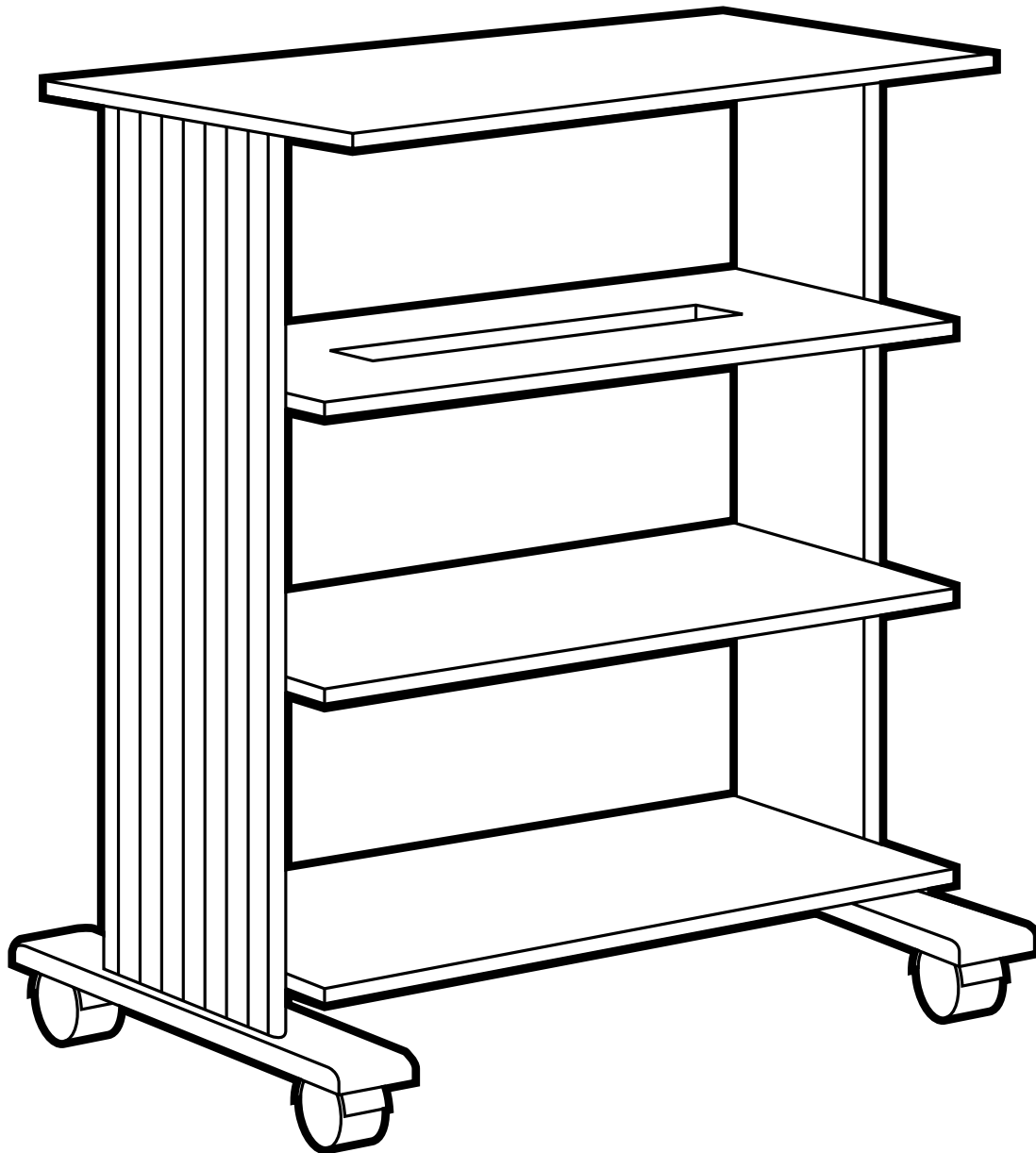

**CUSTOMER
SUPPORT
INFORMATION**

Order **toll-free** in the U.S.: Call **877-877-BBOX** (outside U.S. call **724-746-5500**)
FREE technical support 24 hours a day, 7 days a week: Call **724-746-5500** or fax **724-746-0746**
Mailing address: **Black Box Corporation**, 1000 Park Drive, Lawrence, PA 15055-1018
Web site: www.blackbox.com • E-mail: info@blackbox.com

1. Specifications

Size— 35"H x 29.5"W x 20"D (88.9 x 74.9 x 50.8 cm)

2. Introduction

The 4-Shelf Printer Stand is ideal for dot-matrix, laser, and inkjet printers. You can mount the intermediate shelves at various heights (at increments of 49 inches [125 cm]). One shelf has a slot for the paper feed.

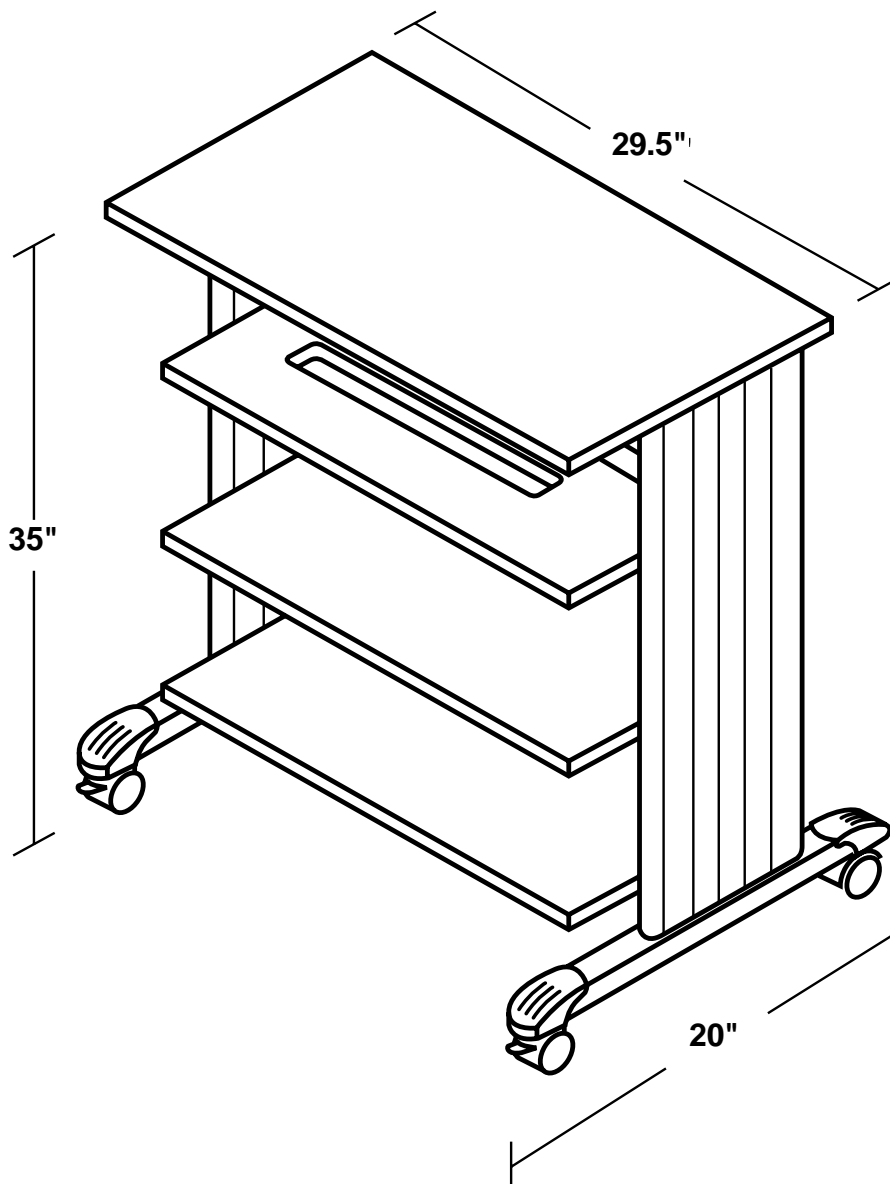

Figure 1. An assembled 4-Shelf Printer Stand.

TRADEMARKS

Any trademarks mentioned in this manual are acknowledged to be the property of the trademark owners.

4-SHELF PRINTER STAND

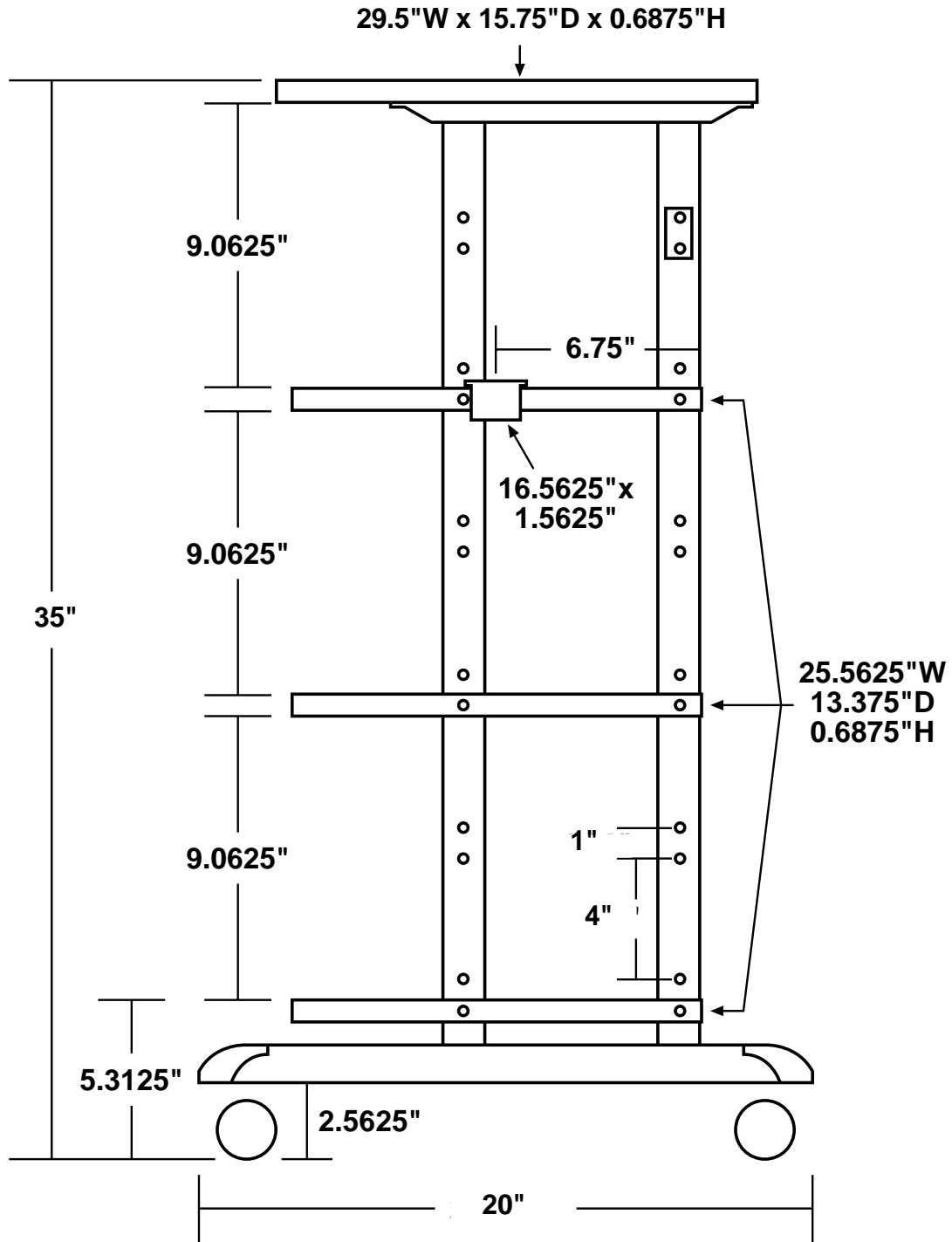

Figure 2. Dimensions.

3. Assembly Instructions

3.1 What the Package Includes

Your package should contain the following items. If anything is missing or damaged, please call Black Box at 724-746-5500.

- (1) top surface ($1\frac{1}{16}$ "H x $25\frac{9}{16}$ "W x $15\frac{3}{4}$ "D)
- (1) cut-out shelf ($1\frac{1}{16}$ "H x $25\frac{9}{16}$ "W x $13\frac{3}{8}$ "D)
- (1) printer/utility shelf ($1\frac{1}{16}$ "H x $25\frac{9}{16}$ "W x $13\frac{3}{8}$ "D)
- (1) bottom shelf ($1\frac{1}{16}$ "H x $25\frac{9}{16}$ "W x $13\frac{3}{8}$ "D)
- (1) plastic insert for cut-out shelf
- (2) leg assemblies
- (2) plastic cable management side covers
- (1) cross bar, used to support all shelves as follows:
 - (4) casters [(2) locking]
 - (4) machine bolts (used to connect the cross bars via the "L" connectors to uprights)
 - (12) large particle wood bolts with aggressive threads (used to attach shelves to uprights)
 - (4) small wood screws (used to attach the top panel to the leg assembly)
 - (1) "Z" allen wrench

3.2 Getting Started

Tip: Remove the cable management side covers and only tighten one side completely. Leave one side a little loose when attaching cross bars and surfaces. When the unit is fully assembled, tighten all bolts completely.

Position all "L" connectors so that the foot of the "L" faces out. Hold the foot of the "L" connectors tight to all the cross bars.

4-SHELF PRINTER STAND

3.3 Assembly Instructions

Follow these steps and refer to **Figure 3** to assemble your 4-Shelf Printer Stand:

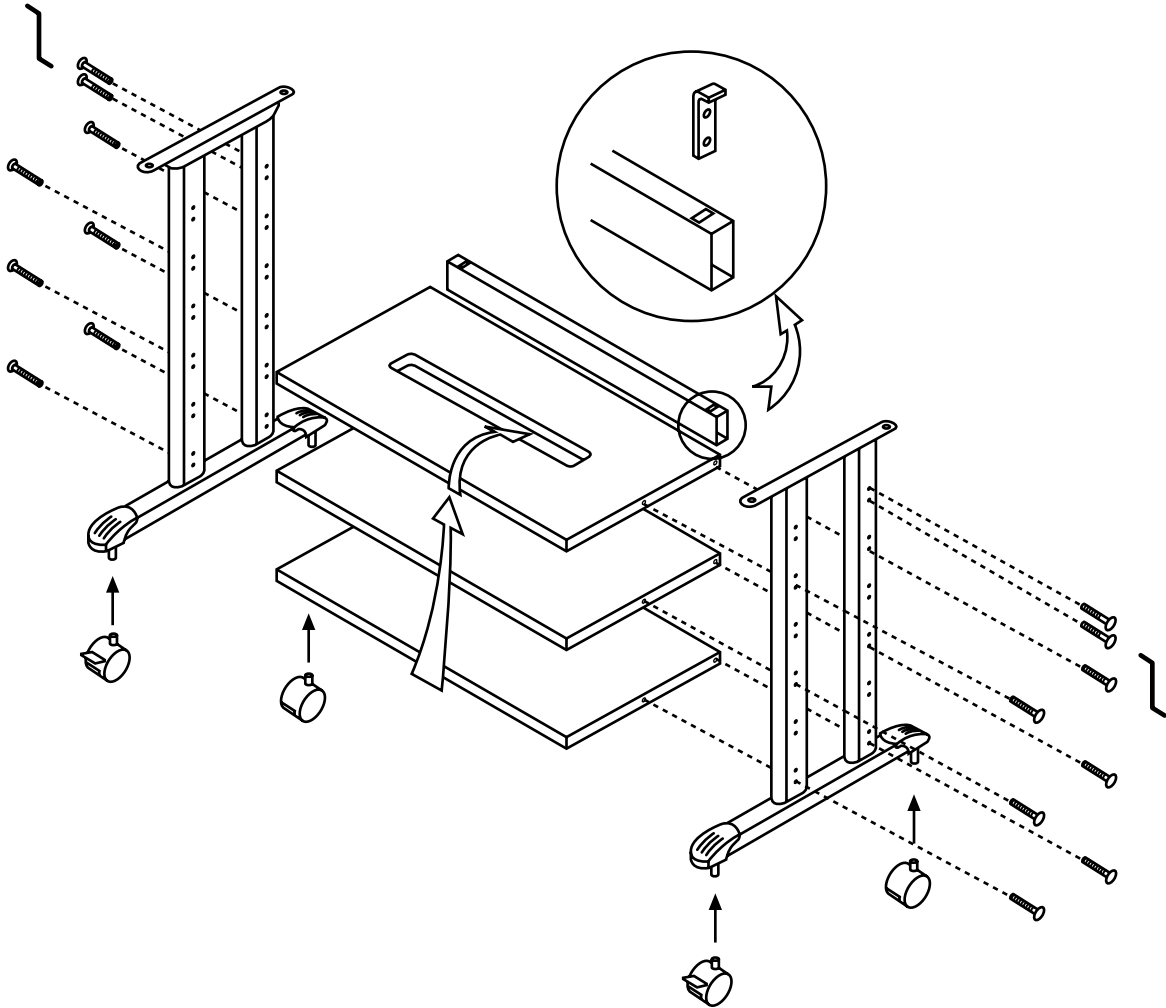

Figure 3. Assembling the Stand.

1. To install the rear steel support cross bars, attach the cross bar to the rear of the leg assembly in the two holes in the top of the leg assembly. (Use two “L” connectors and four machine bolts.) Position the “L” connectors so that the foot of the “L” faces the outside. Tighten one side completely and finger-tighten the other side. The machine bolts will go into the leg assembly.
2. Insert the bottom shelf in the lowest hole position on the leg assembly. Tighten one side completely and finger-tighten the other side.

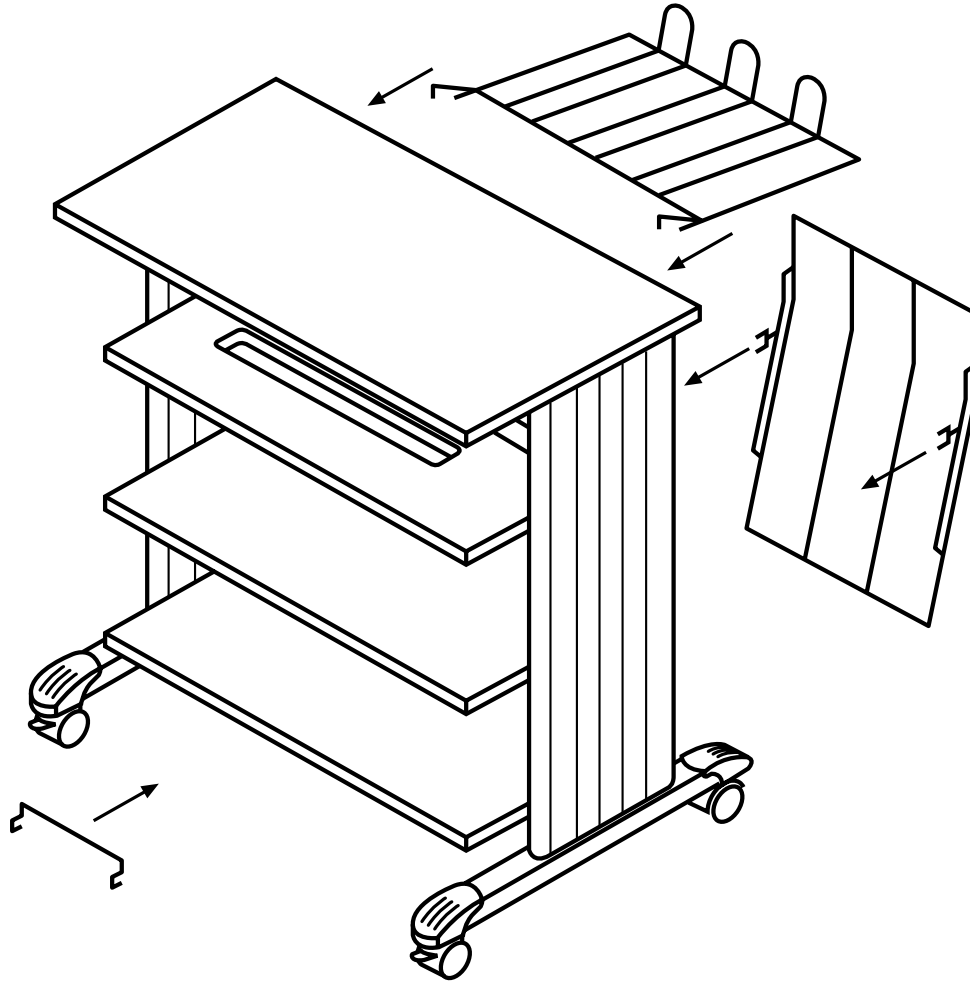

Figure 4. Installing the shelves.

3. Determine the position and height requirements for the remaining shelves. Install them using the aggressive thread particle screws. The shelves can be in any position in any configuration required. Tighten one side completely and finger-tighten the other side.
4. Make sure that the shelf configuration is correct for your needs, then tighten all screws.
5. Place the top panel on the leg assembly (see **Figure 5**). Align the holes in the panel to that of the steel supports. Secure with the four wood screws. Tighten completely.
6. Attach the casters.
7. Snap on the side panels.

4-SHELF PRINTER STAND

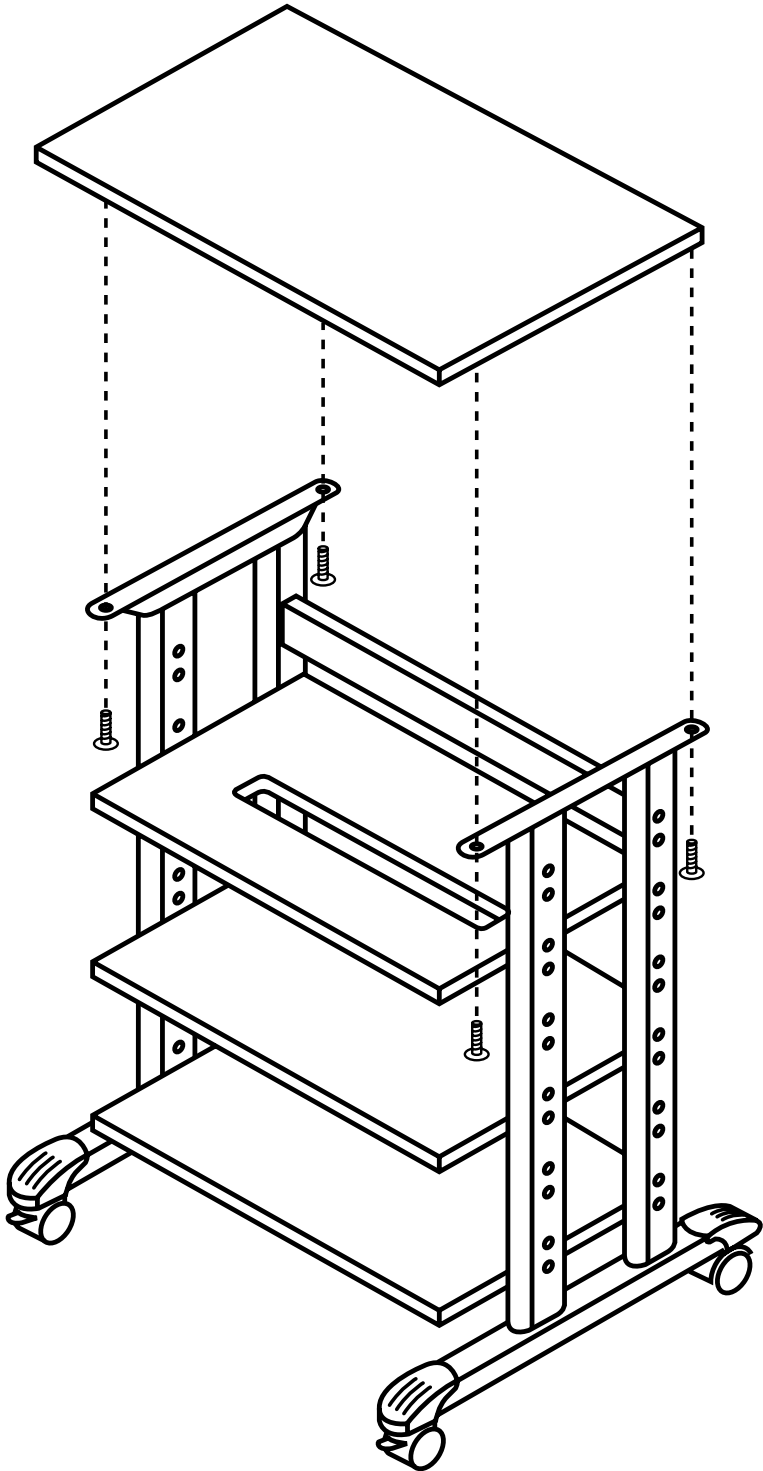

Figure 5. Installing the top panel.

8. Replace the plastic cable management side covers and place the plastic insert in the cut-out shelf.

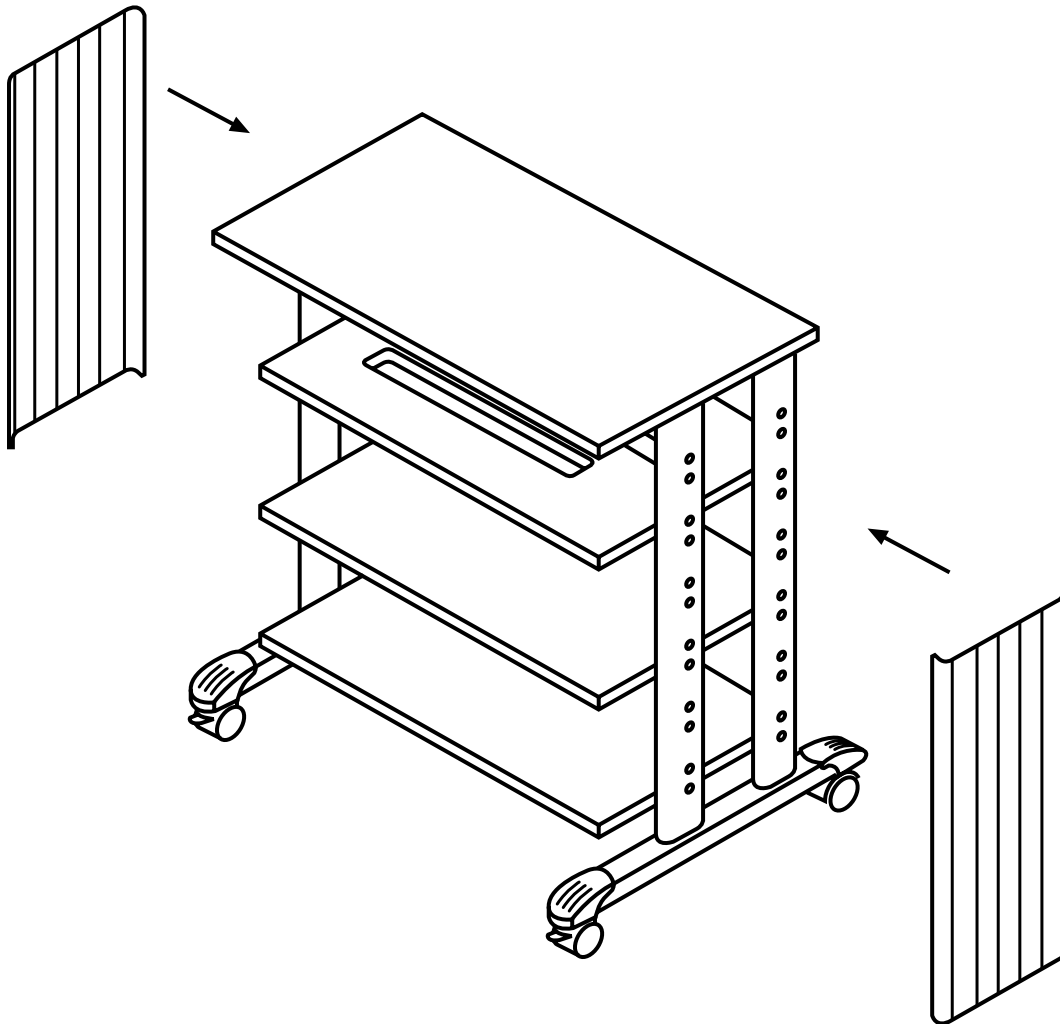

Figure 6. Replacing the plastic cable management side covers.