

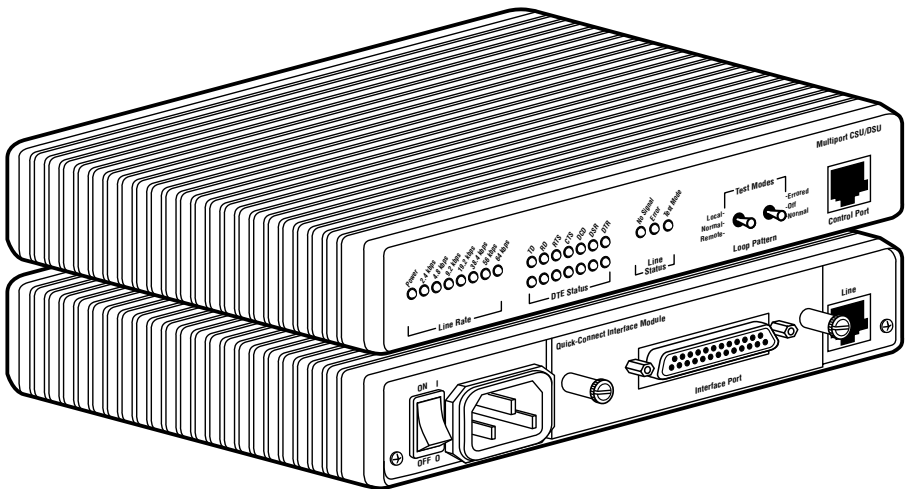

## Multiport CSU/DSU



**CUSTOMER  
SUPPORT  
INFORMATION**

Order toll-free in the U.S.: Call 877-877-BBOX (outside U.S. call 724-746-5500)  
FREE technical support 24 hours a day, 7 days a week: Call 724-746-5500 or fax 724-746-0746  
Mailing address: **Black Box Corporation**, 1000 Park Drive, Lawrence, PA 15055-1018  
Web site: [www.blackbox.com](http://www.blackbox.com) • E-mail: [info@blackbox.com](mailto:info@blackbox.com)

**FEDERAL COMMUNICATIONS COMMISSION  
AND  
CANADIAN DEPARTMENT OF COMMUNICATIONS  
RADIO FREQUENCY INTERFERENCE STATEMENTS**

This equipment generates, uses, and can radiate radio frequency energy and if not installed and used properly, that is, in strict accordance with the manufacturer's instructions, may cause interference to radio communication. It has been tested and found to comply with the limits for a Class A computing device in accordance with the specifications in Subpart J of Part 15 of FCC rules, which are designed to provide reasonable protection against such interference when the equipment is operated in a commercial environment. Operation of this equipment in a residential area is likely to cause interference, in which case the user at his own expense will be required to take whatever measures may be necessary to correct the interference.

Changes or modifications not expressly approved by the party responsible for compliance could void the user's authority to operate the equipment.

*This digital apparatus does not exceed the Class A limits for radio noise emission from digital apparatus set out in the Radio Interference Regulation of the Canadian Department of Communications.*

*Le présent appareil numérique n'émet pas de bruits radioélectriques dépassant les limites applicables aux appareils numériques de la classe A prescrites dans le Règlement sur le brouillage radioélectrique publié par le ministère des Communications du Canada.*



This equipment complies with the Electromagnetic Compatibility (EMC) directive and the Low Voltage Directive (LVD) of the European Union (EU).

### FCC REQUIREMENTS FOR DIGITAL EQUIPMENT

1. This equipment complies with Part 68 of the FCC rules. The unit bears a label that contains the FCC registration number. If requested, you must provide this information to the telephone company.
2. This equipment contains an FCC-compliant modular jack. It is designed to be connected to the digital telephone network or premises wiring using compatible modular plugs and cabling that comply with the requirements of FCC Part 68 rules.
3. In the unlikely event that this equipment causes harm to the telephone network, the telephone company may temporarily disconnect your service. The telephone company will try to warn you in advance of any such disconnection, but if advance notice is not practical, it may disconnect the service first and notify you as soon as possible afterwards. If such a disconnection is necessary, you will be advised of your right to file a complaint with the FCC.
4. From time to time, the Telephone Company may make changes in its facilities, equipment, or operations that could affect the operation of this equipment. If this occurs, the Telephone Company is required to provide you with advance notice so you can make the modifications necessary to maintain uninterrupted service.

**CERTIFICATION NOTICE FOR****EQUIPMENT USED IN CANADA**

The Canadian Department of Communications label identifies certified equipment. This certification means that the equipment meets certain telecommunications-network protective, operation, and safety requirements. The Department does not guarantee the equipment will operate to the user's satisfaction.

Before installing this equipment, users should ensure that it is permissible to be connected to the facilities of the local telecommunications company. The equipment must also be installed using an acceptable method of connection. In some cases, the company's inside wiring associated with a single-line individual service may be extended by means of a certified connector assembly (extension cord). The customer should be aware that compliance with the above conditions may not prevent degradation of service in some situations.

Repairs to certified equipment should be made by an authorized Canadian maintenance facility—in this case, your supplier. Any repairs or alterations made by the user to this equipment, or equipment malfunctions, may give the telecommunications company cause to request the user to disconnect the equipment.

Users should ensure for their own protection that the electrical ground connections of the power utility, telephone lines, and internal metallic water pipe system, if present, are connected together. This precaution may be particularly important in rural areas.

**CAUTION:**

**Users should not attempt to make such connections themselves, but should contact the appropriate electric inspection authority, or electrician, as appropriate.**

The LOAD NUMBER (LN) assigned to each terminal device denotes the percentage of the total load to be connected to a telephone loop which is used by the device, to prevent overloading. The termination on a loop may consist of any combination of devices, subject only to the requirement that the total of the load numbers of all the devices does not exceed 100.

**NORMAS OFICIALES MEXICANAS (NOM)  
ELECTRICAL SAFETY STATEMENT**

**INSTRUCCIONES DE SEGURIDAD**

1. Todas las instrucciones de seguridad y operación deberán ser leídas antes de que el aparato eléctrico sea operado.
2. Las instrucciones de seguridad y operación deberán ser guardadas para referencia futura.
3. Todas las advertencias en el aparato eléctrico y en sus instrucciones de operación deben ser respetadas.
4. Todas las instrucciones de operación y uso deben ser seguidas.
5. El aparato eléctrico no deberá ser usado cerca del agua—por ejemplo, cerca de la tina de baño, lavabo, sótano mojado o cerca de una alberca, etc..
6. El aparato eléctrico debe ser usado únicamente con carritos o pedestales que sean recomendados por el fabricante.
7. El aparato eléctrico debe ser montado a la pared o al techo sólo como sea recomendado por el fabricante.
8. Servicio—El usuario no debe intentar dar servicio al equipo eléctrico más allá a lo descrito en las instrucciones de operación. Todo otro servicio deberá ser referido a personal de servicio calificado.
9. El aparato eléctrico debe ser situado de tal manera que su posición no interfiera su uso. La colocación del aparato eléctrico sobre una cama, sofá, alfombra o superficie similar puede bloquea la ventilación, no se debe colocar en libreros o gabinetes que impidan el flujo de aire por los orificios de ventilación.
10. El equipo eléctrico deber ser situado fuera del alcance de fuentes de calor como radiadores, registros de calor, estufas u otros aparatos (incluyendo amplificadores) que producen calor.
11. El aparato eléctrico deberá ser conectado a una fuente de poder sólo del tipo descrito en el instructivo de operación, o como se indique en el aparato.

12. Precaución debe ser tomada de tal manera que la tierra física y la polarización del equipo no sea eliminada.
13. Los cables de la fuente de poder deben ser guiados de tal manera que no sean pisados ni pellizcados por objetos colocados sobre o contra ellos, poniendo particular atención a los contactos y receptáculos donde salen del aparato.
14. El equipo eléctrico debe ser limpiado únicamente de acuerdo a las recomendaciones del fabricante.
15. En caso de existir, una antena externa deberá ser localizada lejos de las líneas de energía.
16. El cable de corriente deberá ser desconectado del cuando el equipo no sea usado por un largo periodo de tiempo.
17. Cuidado debe ser tomado de tal manera que objetos líquidos no sean derramados sobre la cubierta u orificios de ventilación.
18. Servicio por personal calificado deberá ser provisto cuando:
  - A: El cable de poder o el contacto ha sido dañado; u
  - B: Objetos han caído o líquido ha sido derramado dentro del aparato; o
  - C: El aparato ha sido expuesto a la lluvia; o
  - D: El aparato parece no operar normalmente o muestra un cambio en su desempeño; o
  - E: El aparato ha sido tirado o su cubierta ha sido dañada.

## TRADEMARKS

The trademarks mentioned in this manual are the sole property of their owners.

# Contents

- 1. Specifications . . . . . 8
- 2. Introduction . . . . . 10
  - 2.1 Description . . . . . 10
  - 2.2 Features . . . . . 10
- 3. Configuration . . . . . 12
  - 3.1 Configuring the Hardware DIP Switches . . . . . 12
    - 3.1.1 DIP Switch Set S1 . . . . . 13
    - 3.1.2 DIP Switch Set S2 . . . . . 15
    - 3.1.3 DIP Switch Set S3 . . . . . 19
  - 3.2 Configuring the Software Switches . . . . . 21
    - 3.2.1 Introduction to the Main Menu . . . . . 22
    - 3.2.2 Configuring the Multipoint CSU/DSU . . . . . 23
- 4. Installation . . . . . 29
  - 4.1 Connecting the Serial Port . . . . . 29
    - 4.1.1 Changing the Modules . . . . . 29
    - 4.1.2 Connecting a DTE Device . . . . . 30
    - 4.1.3 Connecting a DCE Device . . . . . 30
    - 4.1.4 Configuring the X.21 Module . . . . . 31
  - 4.2 Connecting the Twisted Pair Interface . . . . . 31
  - 4.3 Connecting Power . . . . . 32
- 5. Operation . . . . . 33
  - 5.1 Power-On . . . . . 33
  - 5.2 LED Status Monitors . . . . . 33
  - 5.3 Loop (V.54 and Telco) Diagnostics . . . . . 34
    - 5.3.1 Operating Local Analog Loopback (LAL) . . . . . 34
    - 5.3.2 Operating Remote Digital Loopback (RDL) . . . . . 35
    - 5.3.3 Telco Testing . . . . . 36
  - 5.4 Bit Error Rate (V.52) Diagnostics . . . . . 36
- Appendix A: Interface Pin Assignments . . . . . 38
- Appendix B: Control Port Pin Assignments . . . . . 41
- Appendix C: Quick Reference for DIP Switch Settings . . . . . 42



# 1. Specifications

**Compatibility**—AT&T 62310

**DDS Line Interface**—Externally accessible RJ-48 female

**Transmission Format**—Synchronous or asynchronous

**Transmission Line**—Two unconditioned twisted pair

**Clock Options**—Internal, external, receive loopback, and campus

**Interfaces**—Modules: RS-232 (DB25 female), RS-422/530 (DB25 female), V.35 (M/34 female), X.21 (DB15), G.703 (RJ-45), Ethernet Bridge

**Speeds**—Synchronous: 2.4, 4.8, 9.6, 19.2, 56, and 64 kbps; Asynchronous: 2.4, 4.8, 9.6, 19.2, 38.4, and 57.6 kbps

**Diagnostics**—V.54-compliant local and remote loopbacks; V.52-compliant 511 and 2047 BER tests

**Indicators**—Front-panel LEDs: DDS line rates (2.4, 4.8, 9.6, 19.2, 38.4, and 57.6 kbps), Power, TD, RD, RTS, CTS, DCD, DSR, DTR, No Signal, Test Mode, Error Indication

**Distance**—-49 dBm receiver sensitivity or better

**RTS/CTS Delay**—0 ms/50 ms

**Front-Panel Switches**—Loopback indication and Bit Error Rate Test

**Temperature Range**—32 to 122 °F (0 to 50 °C)

**Altitude**—Up to 15,000 feet (4572 m)

**Humidity**—5 to 95% noncondensing

**Surge Protection**—600 W Power Dissipation

**Lightning Protection**—Gas Tube

**Isolation**—1500 V via isolation transformers

**Approvals**—FCC Part 68, FCC Part 15, Class A, CE marked per EMC Directive 89/336/EEC and Low Voltage Directive 73/23/EEC, UL and cUL safety approvals

**Power**—Universal Input (UI): 100 to 253 VAC; Input: DC: 18 VDC to 72 VDC, 48 V nominal

**Size**—1.6"H x 7.3"W x 6.6"D (4.1 x 18.5 x 16.8 cm)

**Weight**—2 lb. (0.9 kg)

## 2. Introduction

### 2.1 Description

The Multipoint CSU/DSU (part number MT210A) provides Digital Data Service (DDS) access. It connects to your network devices via your choice of interchangeable interface modules. With sync operation at up to 64 kbps or async at up to 57.6 kbps, the CSU/DSU is versatile, reliable, and hassle-free.

The CSU/DSU complies with AT&T 62310 and supports DDS, Clear Channel 64, and other digital services available from major service providers. Configure the CSU/DSU for the application using externally accessible hardware DIP switches or via menu-driven software switches. After installation, easy-to-read front-panel LED indicators monitor data and control signals. The CSU/DSU also offers convenient V.52 BER and V.54-compliant loop diagnostics.

Replaceable modules come with a variety of interfaces. Select from the following:

- RS-232 (DB25 female) (part number ME481C-232)
- RS-422/530 (DB25 female) (part number ME481C-422)
- V.35 (M/34 female) (part number ME481C-35)
- X.21 (DB15) (part number ME481C-X21)
- G.703 (RJ-45) (part number ME481C-G703)
- Ethernet Bridge (part number ME530A)

The CSU/DSU connects to the line side via an RJ-48 female jack. It receives power from an included 100–253 VAC universal power supply.

For how to connect the modules to a DTE or DCE device, see **Sections 4.1.2** and **4.1.3**. For more information about a specific interface module, refer to the manual supplied with that module.

### 2.2 Features

- Operates over 4-wire dedicated digital lines.
- Synchronous Data Rates: 2.4, 4.8, 9.6, 19.2, 56, and 64 kbps

- Asynchronous Data Rates: 2.4, 4.8, 9.6, 19.2, 38.4, and 57.6 kbps
- Field-replaceable DTE-DCE interface modules: V.24/RS-232, V.35, RS-422/530, G.703, X.21, and Ethernet Bridge
- V.52 BER and V.54-compliant loop diagnostics
- 511 and 2047 Bit Error Rate Tests
- 24 easy-to-read LED indicators to monitor data signals
- Internal, external, received loopback, and campus clock modes
- AT&T 62310 compliant
- Can be used as a high-speed modem for private twisted-pair lines
- Made in the USA

# 3. Configuration

You can configure the Multipoint CSU/DSU via hardware switches or a software control port. This section describes all possible configurations.

## 3.1 Configuring the Hardware DIP Switches

The CSU/DSU has 24 DIP switches that you can configure for a wide variety of applications. The 24 switches are grouped into three eight-switch sets. You can access them externally from the underside of the CSU/DSU (see **Figure 3-1**).

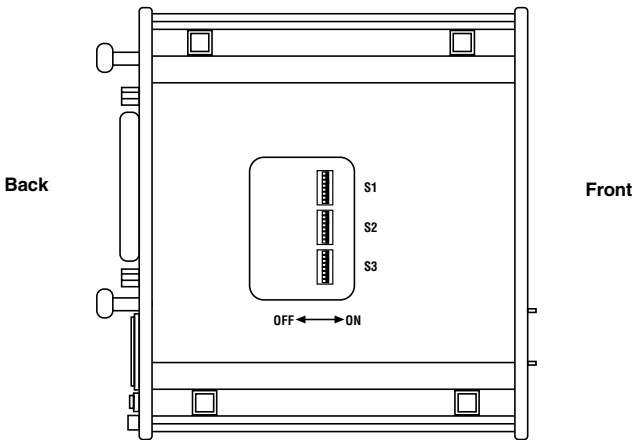

**Figure 3-1. Underside of the CSU/DSU, Showing the Location of the DIP Switches.**

The three sets of DIP switches on the underside of the CSU/DSU will be referred to as S1, S2, and S3. **Figure 3-2** shows the orientation of all DIP switches with respect to “ON” and “OFF” positions.

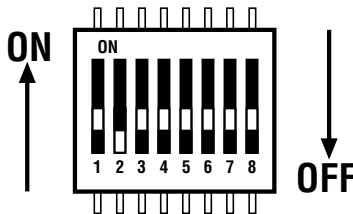

**Figure 3-2. Close-up of Configuration Switches (all three sets are identical in appearance).**

**3.1.1 DIP SWITCH SET S1**

You can use the DIP switches on set S1 to configure the DTE rate, RTS/CTS delay, anti-stream timer, data format, character length, and Extended Signalling Rate (ESR). Default settings are shown in **Table 3-1**. All settings are shown in **Table C-1**. Detailed descriptions for each switch in the set appear below and on **pages 13–14**.

**Table 3-1. S1 Summary Table.**

<b>Position</b>	<b>Function</b>	<b>Factory Default</b>	
S1-1	DTE Rate	Off	} DTE Rate equals Line Rate
S1-2	DTE Rate	Off	
S1-3	DTE Rate	Off	
S1-4	RTS/CTS Delay	Off	Normal
S1-5	Anti-Stream Timer	Off	Off
S1-6	Data Format	Off	Synchronous
S1-7	Character Length	Off	10 Bits
S1-8	Extended Signal Rate	Off	Off

**Switches S1-1, S1-2, and S1-3: Data Rate**

Use switches S1-1, S1-2, and S1-3 to configure the DTE rate of the CSU/DSU. This rate represents the synchronous or asynchronous rate at which the DTE must connect to the CSU/DSU’s interface module.

**Table 3-2. Settings for Switches S1-1, S1-2, and S1-3.**

<b>S1-1</b>	<b>S1-2</b>	<b>S1-3</b>	<b>DTE Rate</b>
On	On	On	2.4 kbps
On	On	Off	4.8 kbps
On	Off	On	9.6 kbps
Off	On	Off	19.2 kbps
On	On	Off	38.4 kbps
Off	On	On	DTE Rate=Line Rate*

**\*NOTE**

**To achieve 56 kbps or 64 kbps, use this switch combination.**

**Switch S1-4: RTS/CTS Delay**

The RTS/CTS delay is the amount of time it takes for CTS to change logic state following an RTS transition. Use Switch S1-4 to select the RTS/CTS delay (measured in msec).

**Table 3-3. Settings for Switch S1-4.**

<b>S1-4</b>	<b>Delay</b>	<b>RTS/CTS Delay in msec. at Various Line Rates</b>				
		<b>56</b>	<b>19.2</b>	<b>9.6</b>	<b>4.8</b>	<b>2.4</b>
Off	Normal	0.3	0.9	1.9	3.8	7.5
On	Extended	1.3	3.8	7.5	15	30

**Switch S1-5: Anti-Stream Timer**

The anti-stream timer protects multidrop networks from a drop that is continuously transmitting. If the DTE keeps RTS raised for more than the time value in seconds, the timer forces RTS off internally. This allows the rest of the multidrop network to resume operation. The CSU/DSU remains in the forced-off condition until the terminal drops RTS. Use Switch S1-5 to enable the timer.

**Table 3-4. Settings for Switch S1-5.**

<b>S1-5</b>	<b>Timer</b>	<b>Timer Value in Sec. at Various Line Rates</b>				
		<b>56</b>	<b>19.2</b>	<b>9.6</b>	<b>4.8</b>	<b>2.4</b>
On	Disabled	<i>not applicable</i>				
Off	Enabled	2	4	8	15	30

**Switch S1-6: Data Format**

Use Switch S1-6 to configure the CSU/DSU for synchronous or asynchronous connection to the DTE.

**Table 3-5. Settings for Switch S1-6.**

<b>S1-6</b>	<b>Setting</b>
Off	Synchronous
On	Asynchronous

*Switch S1-7: Asynchronous Character Length*

Set Switch S1-7 to configure the total number of asynchronous bits per asynchronous character (when Switch S1-6 is set to “On”).

**Table 3-6. Settings for Switch S1-7.**

<b>S1-7</b>	<b>Setting</b>
Off	10 bits
On	11 bits

**NOTE**

The total number of bits in an asynchronous character is determined by the sum of all start bits, data bits, stop bits, and parity bits. For instance:

$$1 \text{ start bit} + 8 \text{ data bits} + 1 \text{ stop bit} + 0 \text{ parity bits} = 10 \text{ bits}$$

*Switch S1-8: Extended Signaling Rate*

Use S1-8 to configure the frequency tolerance the CSU/DSU looks for in asynchronous data rates (the actual variance from a given frequency level the CSU/DSU will tolerate).

**Table 3-7. Settings for Switch S1-8.**

<b>S1-8</b>	<b>Setting</b>
Off	-2.5% to +1%
On	-2.5% to +2.3%

**3.1.2 DIP SWITCH SET S2**

You can use the DIP switches on set S2 to configure the line rate, clock mode, force RTS, and DSR status during local loop. Default settings are shown in **Table 3-8**. All settings are shown in **Table C-2**. Detailed descriptions for each switch in the set appear on **pages 15–17**.



**Table 3-8. S2 Summary Table.**

<b>Position</b>	<b>Function</b>	<b>Factory Default</b>	
S2-1	Line Rate	Off	} 56 kbps
S2-2	Line Rate	On	
S2-3	Line Rate	On	
S2-4	Clock Mode	Off	} Network
S2-5	Clock Mode	Off	
S2-6	Force RTS Signal	Off	Disabled
S2-7	DSR During Local Loop	Off	Off
S2-8	Circuit Assurance	Off	Disabled

*Switches S2-1, S2-2, and S2-3: Line Rate*

Use Switches S2-1, S2-2, and S2-3 to configure the signaling rate on the line (RJ-48 female port). The setting should match the speed of your digital service.

**Table 3-9. Settings for Switches S2-1, S2-2, and S2-3.**

<b>S2-1</b>	<b>S2-2</b>	<b>S2-3</b>	<b>Line Rate</b>
On	On	On	2.4 kbps
On	On	Off	4.8 kbps
On	Off	On	9.6 kbps
On	Off	Off	19.2 kbps
Off	On	On	57.6 kbps
Off	On	Off	64 kbps
Off	Off	Off	Forces configuration to default to hardware control.

**Switches S2-4 and S2-5: Clock Mode**

Use Switches S2-4 and S2-5 to set the source of the CSU/DSU's transmit clock.

**Table 3-10. Settings for Switches S2-4 and S2-5.**

<b>S2-4</b>	<b>S2-5</b>	<b>Clock Mode</b>	<b>Description</b>
On	Off	External (DTE)	Transmit clock derived from terminal interface.
Off	Off	Network (Looped)	Transmit clock derived from the received line signal; use this mode for dedicated DDS operation.
On	On	Internal (Master)	Transmit clock derived internally.
Off	On	Campus Clock	Transmit clock derived from the received line signal. Allows <u>remote</u> device (in campus clock mode) to initiate V.54 loopback. For use only in campus short-haul configuration. (NOTE: <u>Local</u> device must be set in <i>internal</i> clock mode.)

### NOTE

**For X.21 or async campus short-haul modem applications, configure one Multipoint CSU/DSU for internal clock mode and the other CSU/DSU for receive recover clock mode.**

**Switch S2-6: Force RTS**

Use S2-6 to force the transmitter On, thereby ignoring the DTE's RTS signal. In the Off position, RTS controls the transmitter by forcing it to send either the DTE data or an idle pattern.

**Table 3-11. Settings for Switch S2-6.**

<b>S2-6</b>	<b>RTS</b>	<b>Description</b>
On	Forced On	Transmitter is always ON
Off	Follows DTE signal	The RTS input controls the transmitter

***Switch S2-7: Data Set Ready During LOCAL Loopback Test***

Use Switch S2-7 to control the behavior of the DSR signal at the DTE interface during the local loopback test.

**Table 3-12. Settings for Switch S2-7.**

<b>S2-7</b>	<b>Setting</b>
On	DSR is on during local line loop
Off	DSR is off during local line loop

***Switch S2-8: Circuit Assurance***

On dedicated circuits, you can configure the transmitter and the CTS output to go on only when a working communication circuit is established. If Circuit Assurance is used, enable it on only one end of the communication link. Use Switch S2-8 to configure circuit assurance.

**Table 3-13. Settings for Switch S2-8.**

<b>S2-8</b>	<b>Circuit Assurance</b>	<b>Description</b>
On	Enabled	CTS will go low and the transmitter will be held off if the receiver is in the "No Signal" state or CD is low.
Off	Disabled	The transmitter and CTS will operate without regard to the receiver state.

3.1.3 DIP SWITCH SET S3

The configuration switches on S3 set the BER Test pattern, response to remote loop, front-panel switch activation, DTE loop request, and control-port speed. The default settings are shown in **Table 3-14**. All settings appear in **Table C-3**. Detailed descriptions for each switch in the set appear on **pages 18–20**.

**Table 3-14. S3 Summary Table.**

Position	Function	Factory Default	
S3-1	Test Pattern	Off	511
S3-2	RDL Response	Off	Enabled
S3-3	Front Panel Switches	Off	Enabled
S3-4	DTE Loop Request	On	Disabled
S3-5	<i>Reserved for future use</i>		
S3-6	<i>Reserved for future use</i>		
S3-7	Control Port Speed	Off	} 19.2 kbps
S3-8	Control Port Speed	Off	

*Switch S3-1: Test Pattern*

Use Switch S3-1 to set the V.52-compliant pattern used to test the CSU/DSU. The two test options are the 511 and the 2047 BER patterns (for descriptions of these patterns, see **Section 5.4**).

**Table 3-15. Settings for Switch S3-1.**

S3-1	Setting
Off	511 Pattern
On	2047 Pattern

***Switch S3-2: Response to RDL Request***

Use Switch S3-2 to allow the CSU/DSU to enter the Remote Digital Loopback diagnostic test when requested to do so by the remote CSU/DSU. For example, when Switch S1-8 is set to “On,” it will enter RDL mode (see **Section 5.3.2**) when requested to do so by the remote CSU/DSU.

**Table 3-15. Settings for Switch S3-2.**

<b>S3-2</b>	<b>Setting</b>
Off	Response to RDL Request Enabled
On	Response to RDL Request Disabled

***Switch S3-3: Front-Panel Switch Enable/Disable***

Use Switch S3-3 to enable or disable the front-panel switches.

**Table 3-16. Settings for Switch S3-3.**

<b>S3-3</b>	<b>Activation</b>	<b>Description</b>
Off	Enabled	Front-panel switches may be used to activate/terminate diagnostics
On	Disabled	Front-panel switches will have no effect on the operation of the unit

***Switch S3-4: DTE Loop Request Line Enable/Disable***

Use Switch S3-4 to activate or deactivate DTE control of the loopback diagnostic modes and BER test patterns.

**Table 3-17. Settings for Switch S3-4.**

<b>S3-4</b>	<b>Activation</b>	<b>Description</b>
Off	Enabled	DTE loop-request lines may be used to activate/terminate diagnostics
On	Disabled	DTE loop-request lines will have no effect on the operation of the unit

*Switches S3-5 and S3-6: Reserved for Future Use*

Switches S3-5 and S3-6 are *reserved for future use* and must remain in the OFF position.

*Switches S3-7 and S3-8: Control Port Data Rate*

Use Switches S3-7 and S3-8 to configure the CSU/DSU’s control port bit rate.

**Table 3-18. Settings for Switch S3-7 and S3-8.**

<b>S3-7</b>	<b>S3-8</b>	<b>Setting</b>
On	Off	9.6 kbps
Off	Off	19.2 kbps

**3.2 Configuring the Software Switches**

You can configure the Multipoint CSU/DSU via a menu-driven command system. Follow the instructions below.

1. Connect the serial RS-232 port of a VT100 or similar DTE with terminal emulation to the EIA/TIA-5611 port of the CSU/DSU. To construct an RS-232 to EIA-561 patch cable, refer to the control-port pinout diagram in **Appendix A**. For a pre-made cable, refer to **Appendix B** and call Black Box Technical Support at 724-746-5500 for details.
2. Power on the terminal and set its RS-232 port as follows:
  - 19,200 bps (or as defined by DIP Switch S3-8)
  - 8 data bits, 1 stop bit, no parity
  - Local echo
  - CR-CR/LF on inbound data
  - ANSI, VT-100 emulation
3. Power on the CSU/DSU.

4. After the CSU/DSU is powered on, the control port will display the login screen shown in **Figure 3-19**.

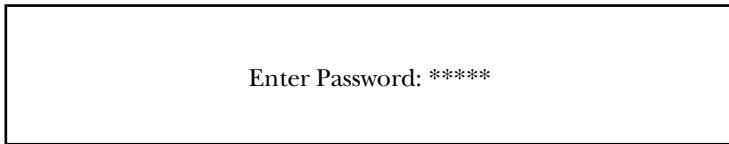
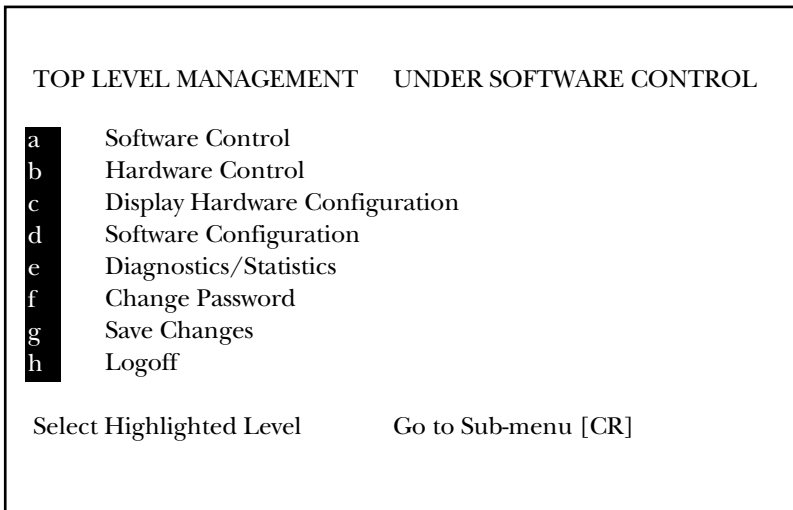

**Figure 3-19. Login Screen.**

5. Enter the password. The initial login password is:  
BLACKBOX
6. The CSU/DSU will then display the Main Menu screen, as shown in **Figure 3-20**.

### 3.2.1 INTRODUCTION TO MAIN MENU

The Main Menu shows the CSU/DSU configuration options. This section describes each of the listed selections.



**Figure 3-20. Main Menu.**

#### *Helpful Hints*

1. To make a selection, type the highlighted letter that corresponds to a menu selection.

2. To execute the selection, type <enter/CR>.
3. Select **g** Save Changes from the Main Menu after making modifications to any CSU/DSU parameter. Otherwise, changes will be lost when you power off the CSU/DSU.
4. The CSU/DSU will display its control status as “Under Hardware Control” or “Under Software Control” in the upper right-hand corner of the Main Menu screen.

### **3.2.2 CONFIGURING THE MULTIPOINT CSU/DSU**

#### **a Software Control**

Select “Software Control” from the Main Menu to place the CSU/DSU under software switch control. When the CSU/DSU is under software switch control, the hardware switch configuration (DIP Switches S1, S2, and S3) will not affect its operation.

#### **b Hardware Control**

Select “Hardware Control” from the Main Menu to place the CSU/DSU under hardware switch control. When the CSU/DSU is under hardware control, the software switch configuration will not affect its operation.



**C Display Hardware Configuration**

Select “Display Hardware Configuration” from the Main Menu to display the configuration of hardware Switches S1, S2, and S3. See **Section 3.1** to review the DIP switch definitions.

Hardware Configuration (Display Only)	
Line Rate	56 kbps
Rate adapter	19.2 kbps
Transmit Clock Source	Network
Data Format	Asynchronous
Character Length	10 Bits
Extended Signal Rate	Normal
RTS/CTS Delay	Extended
Forced RTS	Off
Anti-Stream Timer	On
DSR Loop Status	On
Circuit Assurance	On
Front Panel Switches	Enabled
Response to Remote Loop	Enabled
DTE Loop Request	Disabled
Test Pattern	2047
Control Port Speed	19.2 kbps
Exit = [ESC]	

**Figure 3-21. Display Hardware Configuration Screen.**

## **d** Software Configuration

Select Software Configuration from the Main Menu to display the current settings of the software switches. The software switches control the same parameters described in **Section 3.1, Configuring the Hardware Switches**. See **Section 3.1** to review the hardware switch definitions.

Software Configuration		
a	Line Rate	56.0 kbps
b	Rate Adapter/DTE Rate	19.2 kbps
c	Transmit Clock Source	Network
d	Data Format	Asynchronous
e	Character Length	11 bits
f	Extended Signaling Rate	Extended
g	RTS/CTS Delay	Extended
h	Forced RTS	Off
i	Anti-Stream Timer	On
j	DSR Loop Status	On
k	Circuit Assurance	On
l	Response to Remote Loop	Off
m	DTE Loop Request	Off
n	Control Port Speed	19.2 kbps

Select=[Highlighted Letter]                      Scroll Options=[Space Bar]  
Exit = [ESC]

**Figure 3-22. Software Configuration Screen.**

To modify any of the parameters listed above:

1. Type the highlighted letter that corresponds to a menu selection.
2. Press **[Space Bar]** until the desired value is highlighted.
3. Press **<Enter/CR>** to select the desired value.

## **e** Diagnostics/Statistics

Select “Diagnostics/Statistics” from the Main Menu to monitor or activate/deactivate the CSU/DSU’s BER test patterns and V.54 loop diagnostics. These diagnostics and statistics can help to verify link integrity and isolate communication difficulties.

Diagnostics and Statistics		
<b>a</b>	Select Active Loop	Local
<b>b</b>	Select Test Pattern	None
	Status	
	Active Loop	Local
	Active Test Pattern	None
	Bit Errors Detected	0000
	CD	ON
	RTS	ON
	CTS	ON
Select=[Highlighted Letter]		Select Options=[Space Bar]
Exit = [ESC]		Change Selections=[CR]

**Figure 3-23. Diagnostics and Statistics Screen.**

Active loop conditions are shown below:

- **Local:** Local Analog Loopback is active.
- **Remote:** Remote Digital Loopback is active.
- **Under Remote Loop:** The remote CSU/DSU has initiated a Remote Digital Loopback test.
- **Under CO Loop:** The CO has initiated a CSU Loop or a DSU Loop.

Test patterns are shown below:

- **511:** The 511 BER test is active.
- **511/E:** The 511/E BER test is active.
- **2047:** The 2047 BER test is active.
- **2047/E:** The 2047/E BER test is active.

To activate a loop diagnostic or test pattern:

1. Make sure DIP Switch 3-4 is ON.
2. Type the highlighted letter that corresponds to a menu selection.
3. Press **[Space Bar]** until the desired value is highlighted.
4. Press **<Enter/CR>** to select the desired value.

**f Change Password**

Select Change Password to change the active password of the software configuration menu (see **Figure 3-24**, below).

**g Save Changes**

Select Save Changes to save any modifications in the previous sections. Changes not saved will be lost when you power off the CSU/DSU.

**h Logoff**

Select Logoff to exit the software configuration. After you select Logoff, the CSU/DSU will re-display the login screen.

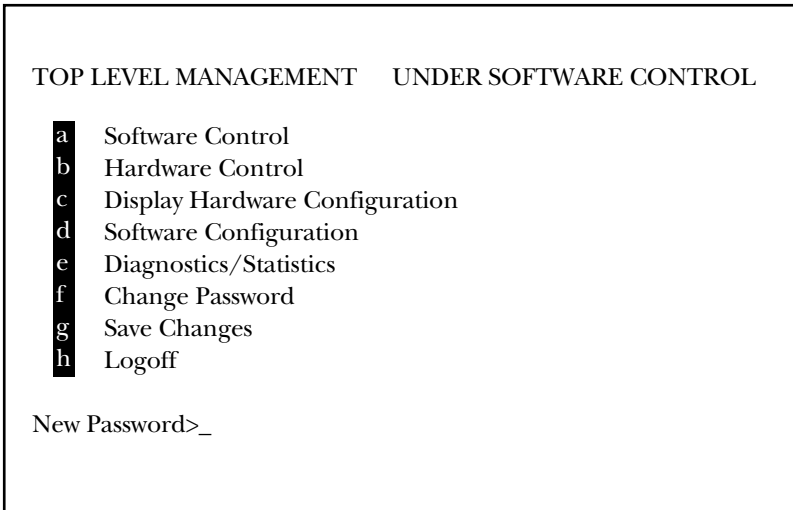

**Figure 3-24. Software Configuration Menu.**

To change the active password:

1. Enter from one to six alphanumeric ASCII characters (0...9, a...z, or A...Z) at the New Password>\_ prompt.
2. Press <Enter/CR>.
3. To review the new password, select **f** Software Configuration from the Main Menu. The new password will be shown as the last item in the software configuration listing.

## 4. Installation

After you properly configure the CSU/DSU, you're ready to connect it to the serial port, twisted-pair interface, and power source. This section explains how to make these connections.

### 4.1 Connecting the Serial Port

The serial port interface on the CSU/DSU uses interchangeable modules to connect to your DTE. Each module has a 50-pin card-edge connector on one side and a serial port on the other. **Figure 4-1** shows how an interface module plugs into the back of the CSU/DSU.

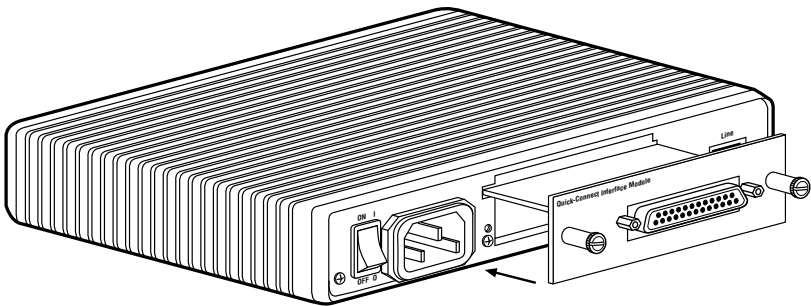

**Figure 4-1. Installing a Plug-In Serial Interface Module into the CSU/DSU.**

#### 4.1.1 CHANGING THE MODULES

To install or remove an interface module (ordered separately; see **page 10** for a complete list of available modules), follow these steps.

*To install an interface module:*

1. Make sure the power switch is off. Leave the power cord plugged into a grounded outlet to keep the CSU/DSU grounded.
2. Hold the module with the faceplate toward you and align the module with the guide slots in the rear panel of the CSU/DSU.

3. While keeping the module's faceplate parallel with the CSU/DSU's rear panel, slide the module straight in, so that the card-edge contacts line up with the socket inside the chassis.

### NOTE

**The card-edge connector should meet the socket when it is almost all the way into the chassis. If you encounter much resistance, remove the module and repeat steps 2 and 3.**

4. With the card edge contacts aligned with the socket, firmly seat the module by using your thumbs to apply pressure directly to the right and left edges of the module faceplate. Applying moderate and even pressure should be sufficient to seat the module. You should hear it "click" into place.
5. To secure the module in place, push the thumbscrews into the chassis and turn the screws clockwise to tighten.

#### *To remove an interface module:*

1. Turn the power switch off. Leave the power cord plugged into a grounded outlet to keep the unit grounded.
2. Loosen the two thumbscrews on the module by turning them counter-clockwise.
3. Grasp the two thumbscrews and gently pull the module from the CSU/DSU. Apply equal force to the thumbscrews to keep the module straight while you remove it.

#### 4.1.2 CONNECTING TO A DTE DEVICE

The serial port on most interface modules (all except the X.21 module) is hard-wired as a DCE. Therefore, these modules plug into a DTE such as a terminal, PC, or host. When connecting to your DTE device, use a straight-through cable of the shortest possible length—we recommend 6 feet (1.8 m) or less. When purchasing or constructing an interface cable, refer to the pin diagrams in **Appendix A** as a guide.

#### 4.1.3 CONNECTING TO A DCE DEVICE

If the CSU/DSU's interface module is hard-wired as a DCE (all except the X.21 module), you must use a null-modem cable when connecting to a modem, multiplexor, or other DCE device. This cable should be of the shortest possible length—we recommend 6 feet (1.8 m) or less. When purchasing or constructing a null-modem interface cable, use the pinout diagrams in **Appendix A** as a guide.

## NOTE

Pinout requirements for null-modem applications vary widely between manufacturers. If you have any questions about a specific application, call Black Box Technical Support at 724-746-5500.

### 4.1.4 CONFIGURING THE X.21 MODULE

The serial port on the X.21 interface module is default wired as a DCE, but may be switched to a DTE. Simply reverse the orientation of the DCE/DTE strap, as described below.

To reverse DCE/DTE orientation, remove the module according to the instructions in **Section 4.1.1**. The DCE/DTE strap is located on the bottom side of the module's PC board. The arrows on the top of the strap indicate the configuration of the X.21 port (for example, if the DCE arrows are pointing toward the DB15 connector, the X.21 port is wired as a DCE). Reverse the DCE/DTE orientation by pulling the strap out of its socket, rotating it 180°, then plugging the strap back into the socket. You will see that the DCE/DTE arrows now point in the opposite directions, showing the new configuration of the X.21 port. Re-install the module according to the instructions in **Section 4.1.1**.

## 4.2 Connecting the Twisted-Pair Interface

The network interface is an 8-position modular connector. Connect this port to the RJ-48 female jack provided by the digital data service provider. If you're using the CSU/DSU for private short-haul communication, the twisted-pair cable will connect to this port. See **Appendix A** for the pin assignments of this connector.

The RJ-48 female connector on the CSU/DSU's twisted-pair interface is pre-wired for a standard telco wiring environment. The signal/pin relationships are shown in **Figure 4-2**.

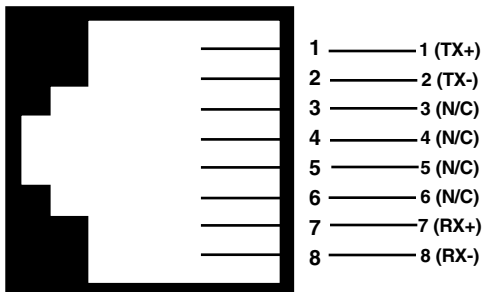

Figure 4-2. CSU/DSU's Twisted-Pair Line Interface.



### 4.3 Connecting Power

The CSU/DSU comes with a universal AC power supply that operates in environments ranging from 100 to 253 VAC, with no reconfiguration. To connect the power supply, follow these steps:

1. Attach the supplied power cord to the shrouded male IEC-320 connector on the rear of the CSU/DSU.
2. Plug the power cord into a nearby AC power outlet.
3. Turn the rear power switch ON.

### **WARNING**

**There are no user-serviceable parts in the power-supply section of the CSU/DSU. Only qualified service personnel should replace the fuse. Call Black Box Technical Support at 724-746-5500 for more information.**

# 5. Operation

After you properly configure and install the Multipoint CSU/DSU, it should operate transparently. This section describes power-on, the LED status monitors, and the built-in loopback test modes.

## 5.1 Power-On

To apply power to the CSU/DSU, first read **Section 4.3**, and make sure that the CSU/DSU is connected to the included power supply. Then turn on the rear power switch.

## 5.2 LED Status Monitors

The CSU/DSU features 24 front-panel LEDs that monitor the line rate, power, DTE signals, network connection, and test modes. **Figure 5-1** shows the front-panel location of each LED. Following **Figure 5-1** is a description of each LED's function.

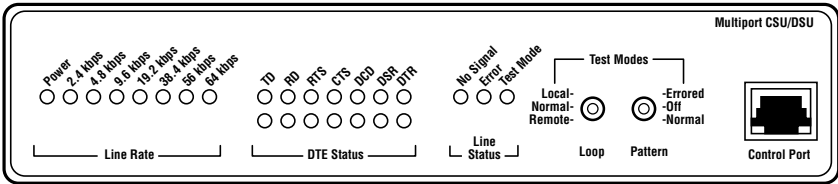

**Figure 5-1. Front Panel of the Multipoint CSU/DSU.**

- **Power**—Glow red when power is present.
- **Line Rate**—The corresponding LED will glow red to indicate the selected line rate.
- **TD and RD**—Glow red to indicate an idle condition of binary 1 data on the respective terminal interface signals. Green indicates binary 0 data.
- **RTS**—Glow green to indicate that the Request to Send signal from the DTE is active.

- **CTS**—Glow green to indicate that the Clear to Send signal from the modem is active.
- **DSR**—Glow green to indicate that the CSU/DSU has asserted the Data Set Ready signal.
- **DCD**—Glow red if no carrier signal is being received from the remote modem. Green indicates that the remote modem's carrier is being received.
- **DTR**—Glow green to indicate that the Data Terminal Ready signal from the terminal is active.
- **ER**—Glow red to indicate that a bit error in the received signal is likely.
- **TM**—Glow red to indicate that the CSU/DSU has been placed in Test Mode. Either the local or remote user can place the CSU/DSU in test mode.
- **NS**—Glow red to indicate that the local CSU/DSU has not yet connected with the central office (or to the remote CSU/DSU when used in a campus short-haul application).

### 5.3 Loop (V.54 and Telco) Diagnostics

The CSU/DSU offers three V.54 loop diagnostics and is compatible with two telco loop diagnostics. Use these diagnostics to test the CSU/DSU and any communication links. These tests can be activated physically from the front panel, or via signals on the module interface.

#### 5.3.1 OPERATING LOCAL ANALOG LOOPBACK (LAL)

The Local Analog Loopback (LAL) test checks the operation of the local CSU/DSU, and is performed separately on each CSU/DSU. As shown in **Figure 5-2**, any data sent to the local CSU/DSU in this test mode will be echoed (returned) back to the user device (characters typed on the keyboard of a terminal will appear on the terminal screen).

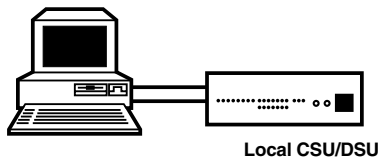

**Figure 5-2. Local Analog Loop.**

To perform a LAL test, follow these steps:

1. Activate LAL, in one of two ways:
  - a. Move the front panel toggle switch up to “Local,” or,
  - b. Activate the “LLB” signal on the DTE. If you are not sure which lead is the LLB signal, refer to **Appendix A**.
2. Verify that the data terminal equipment is operating properly and can be used for a test.
3. Perform a V.54 BER (bit error rate) test as described in **Section 5.3.3**. If the BER test equipment indicates no faults, but the data terminal indicates a fault, follow the manufacturer’s checkout procedures for the data terminal. Also, check the interface cable between the terminal and the CSU/DSU.

**5.3.2 OPERATING REMOTE DIGITAL LOOPBACK (RDL)**

The Remote Digital Loopback (RDL) test checks the performance of both the local and remote CSU/DSUs, as well as the communications link between them. Any characters sent to the remote CSU/DSU in this test mode will be returned back to the originating device (characters typed on the keyboard of the local terminal will appear on the local terminal screen after having been passed to the remote CSU/DSU and looped back).

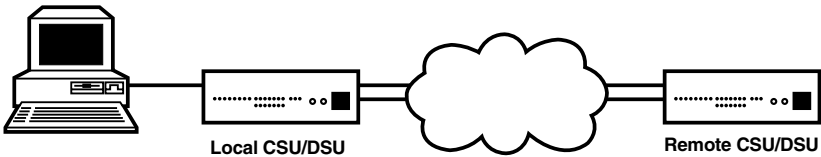

**Figure 5-3. Remote Digital Loop.**

To perform an RDL test, follow these steps:

1. Activate RDL, in one of two ways:
  - a. Move the front panel toggle switch DOWN to “Remote,” or
  - b. Active the “RDL” signal on the DTE. If you are not sure which lead is the RL signal, refer to **Appendix A**.

2. Perform a bit error rate test (BERT) using the internal V.52 generator (as described in **Section 5.4**), or using a separate BER Tester. If the BER test indicates a fault, and the Local Line Loopback test was successful for both CSU/DSUs, you may have a problem with the twisted-pair line between the two units. Check the twisted-pair line for proper connections and continuity.

### 5.3.3 TELCO TESTING

The digital service provider's central office can perform CSU loop and DSU diagnostic testing. These diagnostics allow the central office to evaluate the circuit operation without making visits to the customer's premises.

#### *CSU Loop*

The CSU loop is activated when the central office reverses the DC sealing current that flows between the Transmit (TX) and Receive (RX) pairs. The CSU/DSU recognizes this and loops the signals on the RX pairs back to the central office on the TX pair. While the CSU loop is activated, the TM indicator lights.

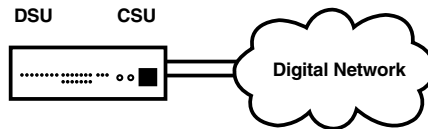

**Figure 5-4. CSU Loop.**

## 5.4 Bit Error Rate (V.52) Diagnostics

The CSU/DSU offers two V.52 Bit Error Rate (BER) test patterns. You can invoke them along with the LAL and RDL tests to evaluate the CSU/DSU(s) and the communication links.

When a 511 or 2047 test is invoked, the CSU/DSU generates a pseudo-random pattern of 511 bits (or 2047 bits) using a mathematical polynomial. The receiving CSU/DSU then decodes the received bits using the same polynomial. If the received bits match the agreed upon pseudo-random pattern, then the CSU/DSUs and the communication links are functioning properly.

- **511:** Initiates a built-in 511 bit pseudo-random pattern generator and detector.

- **511 with Errors:** Initiates a built-in 511 bit pseudo-random pattern generator and detector. The test-pattern generator also injects intentional errors approximately once per second, causing the Error LED to blink.
- **2047:** Initiates a built-in 2047 bit pseudo-random pattern generator and detector.
- **2047 with Errors:** Initiates a built-in 2047 bit pseudo-random pattern generator and detector. The test-pattern generator also injects intentional errors approximately once per second, causing the Error LED to blink.

To perform a V.52 BER test, follow these steps:

1. Select the 511 or 2047 test pattern using DIP Switch 3-1.
2. Locate the “Pattern” toggle switch on the front panel of the CSU/DSU and move it down to “Normal.” This activates the V.52 transmission and reception of the selected test pattern. If there are errors in the received pattern, the error LED will blink accordingly.
3. If the above test indicates that no errors are present, move the toggle switch up to “Errored,” activating the BER test with intentional errors. If the test is working properly, the local modem’s red error LED blinks approximately once per second.

# Appendix A: Interface Pin Assignments

**Table A-1. RS-232, RS-530 Interface Pin Description (DB25 female connector) (DCE Configuration).**

<b>Pin #</b>	<b>Signal</b>
1	FG (Frame Ground)
2	TD (Transmit Data)
3	RD (Receive Data)
4	RTS (Request to Send)
5	CTS (Clear to Send)
6	DSR (Data Set Ready)
7	SGND (Signal Ground)
8	CD (Carrier Detect)
9	RC (Receive Timing-B)
10	CD (Carrier Detect-B)
11	XTC (External Transmit Clock)
12	TC (Transmit Clock-B)
13	CTS (Clear to Send)
14	TD (Transmit Data-B)
15	TC (Transmit Clock)
16	RD (Receive Data)
17	RC (Receive Clock)
18	LLB (Local Line Loop)
19	RTS (Request to Send)
20	DTR (Data Terminal Ready)
21	RDL (Remote Digital Loop)
22	DSR (Data Set Ready)
23	DTR (Data Terminal Ready)
24	XTC (External Transmit Clock)
25	TM (Test Mode)

**Table A-2. V.35 Interface (M/34 female connector) (DCE Configuration).**

<b>Pin #</b>	<b>Signal</b>
B	SGND (Signal Ground)
C	RTS (Request to Send)
D	CTS (Clear to Send)
E	DSR (Data Set Ready)
F	CD (Carrier Detect)
H	DTR (Data Terminal Ready)
L	LLB (Local Line Loop)
M	TM (Test Mode)
N	RDL (Remote Digital Loop)
P	TD (Transmit Data-A)
R	RD (Receive Data-A)
S	TD (Transmit Data-B)
T	RD (Receive Data-B)
U	XTC (External Transmit Clock)
V	RC (Receive Clock)
W	XTC (External Transmit Clock)
X	RC (Receive Clock-B)
Y	TC (Transmit Clock-A)
AA	TC (Transmit Clock-B)



**Table A-3. X.21 Interface (DB15 female connector) (DTE/DCE Configuration).**

<b>Pin #</b>	<b>Signal</b>
1 -----	Frame Ground
2 -----	T (Transmit Data-A)
3 -----	C (Control-A)
4 -----	R (Receive Data-A)
5 -----	I (Indication-A)
6 -----	S (Signal Element Timing-A)
8 -----	SGND (Signal Ground)
9 -----	T (Transmit Data-B)
10 -----	C (Control-B)
11 -----	R (Receive Data-B)
12 -----	I (Indication-B)
13 -----	S (Signal Element Timing-B)

# Appendix B: CSU/DSU Control Port Pinout

The CSU/DSU control port is an 8-position connector that complies with EIA/TIA-561.

**Table B-1. CSU/DSU Control Port Pinout.**

<b>Pin Function</b>	<b>RJ-45 Pin Number</b>
Ground	4
Receive Data (to DTE)	5
Transmit Data (from DTE)	6

# Appendix C: Quick Reference for DIP Switch Settings

Table C-1. DIP Switch S1 Settings.

DIP Switch S1	Position 1	2	3	4	5	6	7	8
<u>DTE Rate</u>								
2.4 kbps	On	On	On					
4.8 kbps	On	On	Off					
9.6 kbps	On	Off	On					
19.2 kbps	Off	On	Off					
38.4 kbps	On	On	Off					
DTE Rate=	Off*	On*	On*					
Line Rate*								
<u>RTS/CTS Delay</u>								
Normal*				Off*				
Extended				On				
<u>Anti-Stream Timer</u>								
Disabled					On			
Enabled*					Off*			
<u>Data Format</u>								
Synchronous*						Off*		
Asynchronous						On		
<u>Asynchronous Character Length</u>								
10 bits*							Off*	
11 bits							On	
<u>Extended Signaling Rate</u>								
-2.5% to +1%*								Off*
-2.5% to +2.3%								On

\*Factory default settings for DIP Switch S1.

For more information about DIP Switch S1 settings, see **Section 3.1.1**.

Table C-2. DIP Switch S2 Settings.

DIP Switch S2	Position		3	4	5	6	7	8
	1	2						
<u>Line Rate</u>								
2.4 kbps	On	On	On					
4.8 kbps	On	On	Off					
9.6 kbps	On	Off	On					
19.2 kbps	On	Off	Off					
56 kbps*	Off*	On*	On*					
64 kbps	Off	On	Off					
**See note.	Off	Off	Off					
<u>Clock Mode</u>								
External (DTE)				On	Off			
Network (Looped)*				Off*	Off*			
Internal (Master)				On	On			
Campus Clock				Off	On			
<u>Force RTS</u>								
Forced On						On		
Follows DTE Signal*						Off*		
<u>Data Set Ready During Local Loopback Test</u>								
DSR on during local line loop							On	
DSR off during local line loop*							Off*	
<u>Circuit Assurance</u>								
Enabled								On
Disabled*								Off*

**\*\*NOTE**

**Forces configuration pointer to default to hardware control.**

\*Factory default settings for DIP Switch S2.

For more information about DIP Switch S2 settings, see **Section 3.1.2**.

**Table C-3. DIP Switch S3 Settings.**

<b>DIP Switch S3</b>	<b>Position</b>		<b>3</b>	<b>4</b>	<b>5</b>	<b>6</b>	<b>7</b>	<b>8</b>
<u>Test Pattern</u>								
511 BER*	Off*							
2047 BER	On							
<u>Response to RDL Request</u>								
Enabled*	Off*							
Disabled	On							
<u>Front Panel Switch</u>								
Enabled*			Off*					
Disabled			On					
<u>DTE Loop Request Line</u>								
Enabled				Off				
Disabled*				On*				
Not used					Off*	Off*		
<u>Control Port Data Rate</u>								
9.6 kbps							On	Off
19.2 kbps*							Off*	Off*

**NOTE**

**DIP Switches S3-5 and S3-6 are reserved for future use and must remain in the Off position.**

\*Factory default settings for DIP Switch S3.  
 For more information about DIP Switch S3 settings, see **Section 3.1.3**.



© Copyright 1999. Black Box Corporation. All rights reserved.

---

1000 Park Drive • Lawrence, PA 15055-1018 • 724-746-5500 • Fax 724-746-0746