

Welcome to the ServSwitch™ Family!

Thank you for purchasing a BLACK BOX® ServSwitch™ Brand KVM switch! We appreciate your business, and we think you'll appreciate the many ways that your new ServSwitch keyboard/video/mouse switch will save you money, time, and effort.

That's because our ServSwitch family is all about breaking away from the traditional, expensive model of computer management. You know, the one-size-fits-all-even-if-it-doesn't model that says, "One computer gets one user station, no more, no less." Why not a single user station (monitor, keyboard, and mouse) for multiple computers—even computers of different platforms? Why not a pair of user stations, each of which can control multiple computers? Why not multiple user stations for the same computer?

With our ServSwitch products, there's no reason why not. We carry a broad line of robust solutions for all these applications. Do you have just two PCs, and need an economical alternative to keeping two monitors, keyboards, and mice on your desk? Or do you need to share dozens of computers, including a mix of PC, Mac®, and Sun Microsystems® types, among multiple users with different access levels? Does your switch have to sit solidly on a worktable and use regular everyday cables? Or does it have to be mounted in an equipment rack and use convenient many-to-one cables? No matter how large or small your setup is, no matter how simple or how complex, we're confident we have a ServSwitch system that's just right for you.

The ServSwitch™ family from Black Box—the one-stop answer for all your KVM-switching needs!

*

This manual will tell you all about your new ServShare™ unit, including how to install, operate, and troubleshoot it. For an introduction to the ServShare, see **Chapter 2**. The ServShare product codes covered in this manual are:

KV752A
KV752AE
KV754A
KV754AE

TRADEMARKS USED IN THIS MANUAL

BLACK BOX and the  logo are registered trademarks, and ServSwitch and ServShare are trademarks, of Black Box Corporation.

Mac is a registered trademark of Apple Computer, Inc.

IBM, PC/AT, PS/2, RS/6000, and ThinkPad are registered trademarks, and PC/XT is a trademark, of International Business Machines Corporation.

Microsoft and Windows are registered trademarks and/or trademarks of Microsoft Corporation in the United States and/or other countries.

Sun and Sun Microsystems are registered trademarks of Sun Microsystems, Inc. in the United States and other countries.

Any other trademarks mentioned in this manual are acknowledged to be the property of the trademark owners.

**FEDERAL COMMUNICATIONS COMMISSION
AND
INDUSTRY CANADA
RADIO-FREQUENCY INTERFERENCE STATEMENTS**

This equipment generates, uses, and can radiate radio frequency energy and if not installed and used properly, that is, in strict accordance with the manufacturer's instructions, may cause interference to radio communication. It has been tested and found to comply with the limits for a Class A computing device in accordance with the specifications in Subpart J of Part 15 of FCC rules, which are designed to provide reasonable protection against such interference when the equipment is operated in a commercial environment. Operation of this equipment in a residential area is likely to cause interference, in which case the user at his own expense will be required to take whatever measures may be necessary to correct the interference.

Changes or modifications not expressly approved by the party responsible for compliance could void the user's authority to operate the equipment.

This digital apparatus does not exceed the Class A limits for radio noise emission from digital apparatus set out in the Radio Interference Regulation of Industry Canada.

Le présent appareil numérique n'émet pas de bruits radioélectriques dépassant les limites applicables aux appareils numériques de la classe A prescrites dans le Règlement sur le brouillage radioélectrique publié par Industrie Canada.

NORMAS OFICIALES MEXICANAS (NOM) ELECTRICAL SAFETY STATEMENT

INSTRUCCIONES DE SEGURIDAD

1. Todas las instrucciones de seguridad y operación deberán ser leídas antes de que el aparato eléctrico sea operado.
2. Las instrucciones de seguridad y operación deberán ser guardadas para referencia futura.
3. Todas las advertencias en el aparato eléctrico y en sus instrucciones de operación deben ser respetadas.
4. Todas las instrucciones de operación y uso deben ser seguidas.
5. El aparato eléctrico no deberá ser usado cerca del agua—por ejemplo, cerca de la tina de baño, lavabo, sótano mojado o cerca de una alberca, etc..
6. El aparato eléctrico debe ser usado únicamente con carritos o pedestales que sean recomendados por el fabricante.
7. El aparato eléctrico debe ser montado a la pared o al techo sólo como sea recomendado por el fabricante.
8. Servicio—El usuario no debe intentar dar servicio al equipo eléctrico más allá a lo descrito en las instrucciones de operación. Todo otro servicio deberá ser referido a personal de servicio calificado.
9. El aparato eléctrico debe ser situado de tal manera que su posición no interfiera su uso. La colocación del aparato eléctrico sobre una cama, sofá, alfombra o superficie similar puede bloquea la ventilación, no se debe colocar en libreros o gabinetes que impidan el flujo de aire por los orificios de ventilación.
10. El equipo eléctrico deber ser situado fuera del alcance de fuentes de calor como radiadores, registros de calor, estufas u otros aparatos (incluyendo amplificadores) que producen calor.
11. El aparato eléctrico deberá ser conectado a una fuente de poder sólo del tipo descrito en el instructivo de operación, o como se indique en el aparato.

12. Precaución debe ser tomada de tal manera que la tierra física y la polarización del equipo no sea eliminada.
13. Los cables de la fuente de poder deben ser guiados de tal manera que no sean pisados ni pellizcados por objetos colocados sobre o contra ellos, poniendo particular atención a los contactos y receptáculos donde salen del aparato.
14. El equipo eléctrico debe ser limpiado únicamente de acuerdo a las recomendaciones del fabricante.
15. En caso de existir, una antena externa deberá ser localizada lejos de las líneas de energía.
16. El cable de corriente deberá ser desconectado del cuando el equipo no sea usado por un largo periodo de tiempo.
17. Cuidado debe ser tomado de tal manera que objetos líquidos no sean derramados sobre la cubierta u orificios de ventilación.
18. Servicio por personal calificado deberá ser provisto cuando:
 - A: El cable de poder o el contacto ha sido dañado; u
 - B: Objetos han caído o líquido ha sido derramado dentro del aparato; o
 - C: El aparato ha sido expuesto a la lluvia; o
 - D: El aparato parece no operar normalmente o muestra un cambio en su desempeño; o
 - E: El aparato ha sido tirado o su cubierta ha sido dañada.

Contents

Chapter	Page
1. Specifications	8
2. Introduction	10
2.1 The Complete Package	10
2.2 Operating Features	10
2.3 The Front Panel	12
2.4 The Rear Panel	14
2.5 Cable Requirements	15
3. Installation	16
3.1 Quick Setup Guide	16
3.2 Installation Procedure	17
3.2.1 Rackmounting (Optional)	17
3.2.2 Connecting the CPU	17
3.2.3 Connecting the Keyboards, Monitors, and Mice	18
3.2.4 Powering Up the System	19
4. Operation	20
4.1 Guidelines for using the ServShare with Your Equipment	20
4.1.1 CPU	20
4.1.2 Mice and Keyboards	20
4.1.3 Monitors	21
4.2 Setting the Configuration DIP Switch	24
4.3 Keyboard-Command Summary	24
4.4 The Commands in Detail	27
4.4.1 Keep Settings	27
4.4.2 Set Keyboard Timeout (From Station 1 Only)	27
4.4.3 Set Keyboard Mode	27
4.4.4 Set Keyboard Typematic	29
4.4.5 Set Mouse Translation (From Station 1 Only)	31
4.4.6 Set Video-Blanking Delay	31
4.4.7 Enable, Disable, or Freeze Other User Stations	32
4.4.8 Reset	32
4.4.9 Send Null Byte (Only If CPU Is Using PS/2 Mouse Port) ..	33
4.4.10 Identify ROM	33

Chapter	Page
5. Troubleshooting	34
5.1 Common Problems	34
5.1.1 CPU Doesn't Boot	34
5.1.2 Can't Enter Keyboard Commands	35
5.1.3 Typed Characters Wrong or Missing	35
5.1.4 Mouse Driver Doesn't Load	36
5.1.5 Can't Access Mouse Functions	36
5.1.6 PS/2 Mouse Gets Out of Sync	36
5.1.7 Mouse Doesn't Move Pointer/Cursor	37
5.1.8 Display is Blank or Fuzzy	37
5.1.9 Video Not Synchronized or Wrong Color	38
5.1.10 Can't Access High-Resolution Mode	38
5.1.11 CPU Locks Up When Windows 3.x Loaded	38
5.1.12 ServShare Doesn't Work with Docking Station	38
5.1.13 ServShare Doesn't Work with Dongle-Protected Software ..	38
5.1.14 Status LED Flashes, ServShare Doesn't Work at All	38
5.2 Calling Black Box	39
5.3 Shipping and Packaging	39
 Appendix A: NVRAM Factory Defaults	 40
 Appendix B: Cable Product Codes	 41
 Appendix C: Rackmounting the ServShare	 43
C.1 Mounting 2-Port (KV752) Units	43
C.2 Mounting 4-Port (KV754) Units	43

1. Specifications

Compliance —	FCC Part 15 Subpart J Class A, IC Class/classe A
Standards —	With original Serv cabling: VGA (color or monochrome/page white) video; With original Serv cabling (minimal) or coaxial cabling (recommended): SVGA video; With coaxial cabling: XGA (color or monochrome) video
Interfaces —	All CPU and KVM ports: Proprietary composite of IBM PS/2 or PC/AT keyboard, PS/2 or RS-232 mouse, and VGA/SVGA/XGA video RS-232 port: Proprietary variant of EIA/TIA RS-232-D using RJ-12 (“6-wire RJ-11”) connectors, DTE;
Resolution —	With original Serv cabling: Up to 1024 x 768 noninterlaced; With coaxial cabling: Up to 1280 x 1024 noninterlaced
Maximum Distance —	Depending on the CPU, monitor, and video resolution (see Section 4.1.3): 40 ft. (12.2 m) of total original Serv cable from any keyboard, monitor, and mouse to the CPU; or 20 ft. (6.1 m) of coaxial cable—possibly as much as 100 ft. (30.5 m), depending on the CPU—from any ServShare to any device attached to it
User Controls —	Keyboard commands; Front-mounted 8-position DIP switch; Rear-mounted power (ON/OFF) pushbutton
Indicators —	All front-mounted LEDs: (1) Power; (1) Remote Video; KV752A, KV752AE: (2) Status (active station); KV754A, KV754AE: (4) Status (active station)

Connectors —	Front-mounted; (1) DB25 female for CPU; KV752A, KV752AE: (2) DB25 female for keyboard, video, and mouse; KV754A, KV754AE: (4) DB25 female for keyboard, video, and mouse; Rear-mounted; (1) RJ-12 female for RS-232; (1) 5-pin DIN for power
Power —	KV752A, KV754A: From wallmount power supply PS018: Optimal input: 120 VAC, 60 Hz, 100 mA; Output: 16.5 VAC CT, 1.45 amps; Consumption: Up to 23.9 VA (23.9 watts); KV752AE, KV754AE: From desktop power supply PS018E: Optimal input: 230 VAC, 50 Hz, 60 mA; Output: 16.5 VAC CT, 1.45 amps; Consumption: Up to 23.9 VA (23.9 watts)
Maximum Altitude—	10,000 ft. (3048 m)
Temperature Tolerance—	32 to 131°F (0 to 55°C)
Humidity Tolerance—	5 to 80% noncondensing
Enclosure —	Steel
Size —	KV752A, KV752AE: 2.1"H x 8.9"W x 4.9"D (5.3 x 22.5 x 12.5 cm); KV754A, KV754AE: 5.3"H x 13.1"W x 4.9" D (13.5 x 33.3 x 12.5 cm)
Weight —	KV752A, KV752AE: 3 lb. (1.4 kg); KV754A, KV754AE: 7 lb. (3.2 kg)

2. Introduction

Thank you for choosing a ServShare™. Your new ServShare will simplify your job by helping you organize your multiple-user, single-CPU application. Because the ServShare lets you use two to four keyboards, monitors, and mice to access a single IBM® PC compatible computer, your users can share your important PC data and applications.

This chapter describes everything that comes with the ServShare, its external and operating features, and the cabling you'll need for it.

2.1 The Complete Package

Your ServShare package includes the ServShare unit, its power supply, and this manual. If anything arrived damaged, contact Black Box.

2.2 Operating Features

Some of the useful features of your ServShare:

- You can share access to a single IBM PC compatible CPU with two, three, or four user stations (keyboards, monitors, and mice).
- Fully automatic CPU sharing on a first-come, first-served basis.
- Can display video to all user stations simultaneously.
- Handles access contention with a user-adjustable keyboard timeout.
- Independently user-adjustable video-blanking timeout and keyboard-typematic rate and delay for each station.
- You can use “enable,” “disable,” and “freeze” commands to enable/disable keyboard, mouse, and video functions at the other user stations for temporary privacy or uninterruptibility.
- You can use DIP switches to enable/disable keyboard commands from any user station.
- Front-panel status LEDs flash every second to show on-line status or to show when activity has been detected on a station's keyboard or mouse.
- Supports SVGA and color or monochrome XGA or VGA video at resolutions up to 1280 x 1024 noninterlaced (although all video types except VGA require coaxial or special cables).

- Depending on the CPU, can drive keyboard, video, and mouse signals across as much as 100 ft. (30.5 m) of coaxial Serv cable.
- Supports all modes of PS/2® and PC/AT® compatible keyboards.
- Instant keyboard-LED synchronization.
- Mouse can be any 2-button PS/2 or RS-232 serial type by Microsoft® or Logitech™. (The ServShare can translate PS/2 mouse data to serial or serial mouse data to PS/2.)
- Automatically re-enables PS/2 mouse when the mouse is disconnected and then reconnected.
- A rackmount kit is also available.

2.3 The Front Panel

The ServShare’s front panel features a DIP switch, four to six LED indicators, and three to five DB25 female connectors. To familiarize yourself with these components, refer to Figures 2-1 and 2-2 and the descriptions that follow.

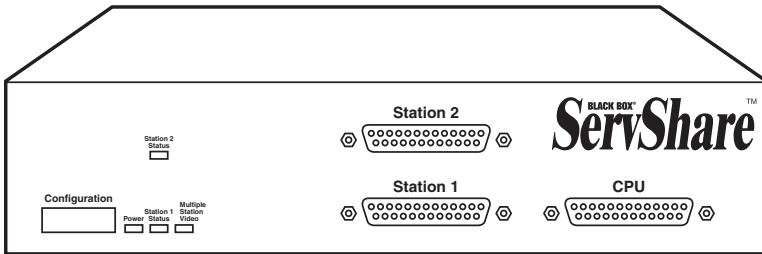

Figure 2-1. The front panel of a 2-port ServShare (KV752 model).

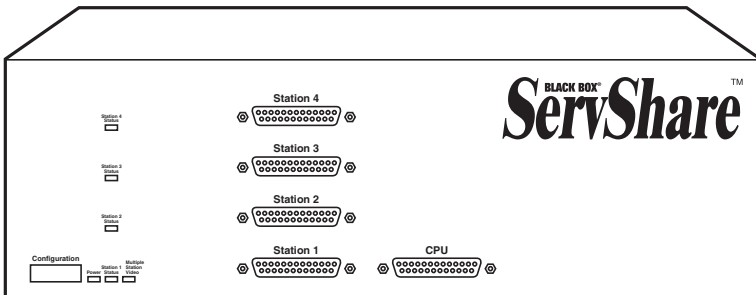

Figure 2-2. The front panel of a 4-port ServShare (KV754 model).

<i>Panel Label</i>	<i>Description</i>
Configuration	Configuration DIP Switch: Set the positions of this switch UP to enable or DOWN to disable keyboard-command input from user stations. Switch position 8 (far right) controls station 1 and position 7 (2nd from right) controls station 2; on KV754 models, position 6 (3rd from right) controls station 3 and position 5 (4th from right) controls station 4.
Power	Power LED: Lights to indicate that unit is powered ON.

<i>Panel Label</i>	<i>Description</i>
Station 1, 2, 3, 4 Status	Station Status LEDs: Should flash once a second to show that the ServShare's user-station daughterboards are communicating with each other. Also flashes whenever data is detected from the corresponding user station's keyboard or mouse.
Multiple Station Video	Multiple Shared Video (MSV) LED: Lights when the ServShare is sending video to the user stations other than station 1 (station 2 on KV752 models or stations 2, 3, and 4 on KV754 models).
Station 1, 2, 3, 4	Station MKM (Monitor/Keyboard/Mouse) Ports: You will run MKM Adapter Cables from these DB25 female connectors to your user stations (keyboards, monitors, and mice).
CPU	CPU Port: You will run CPU Adapter Cables from this DB25 female connector to the CPU your users are sharing.

2.4 The Rear Panel

The ServShare's rear panel contains its RS-232 port and its power switch and connector; refer to Figures 2-3 and 2-4 and the descriptions that follow.

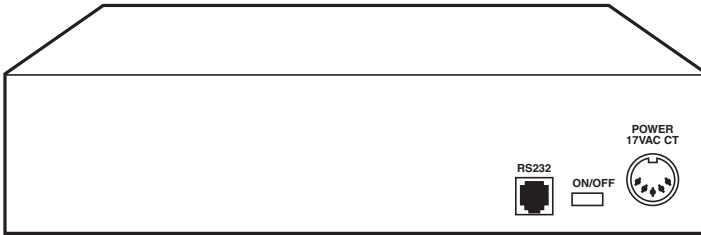

Figure 2-3. The rear panel of a 2-port ServShare (KV752 model).

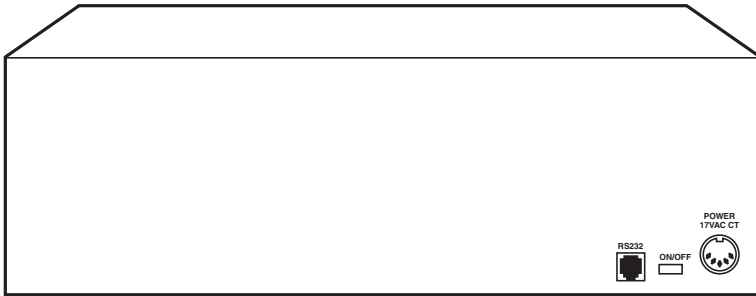

Figure 2-4. The rear panel of a 4-port ServShare (KV754 model).

<i>Panel Label</i>	<i>Description</i>
RS-232	RS-232 Port: Proprietary pinned RJ-12 female connector used only for factory diagnostics.
ON/OFF	Power Switch: Pressing this pushbutton turns the ServShare ON and OFF.
POWER 17 VAC CT	Power Inlet: You will attach the output cord of the ServShare's power supply to this 5-pin DIN female connector.

2.5 Cable Requirements

Many switches of this type have what seems like ten million connectors on their rear panels: one for each monitor cable, one for each keyboard cable, and a third for each mouse cable. The potential for tangling or mismatching cables is high.

By contrast, you can connect the ServShare to your user-station equipment with one “MKM (Monitor/Keyboard/Mouse) Adapter Cable” for each station. You’ll plug your monitor, keyboard, and mouse cables into this Adapter Cable instead of into the ServShare itself.

You can connect the ServShare to your CPU with a “CPU Adapter Cable” that reaches its video-output, keyboard, and mouse ports.

The exact variety or varieties of these cables that you’ll need will depend on the equipment you are connecting for your application. Refer to **Appendix B** for the available types of these cables and the corresponding product codes. Also refer to **Chapter 1** or the Caution notice on page 17 for information about maximum cabling distances.

NOTES

SVGA (over longer distances) and XGA video place special demands on cabling that the regular MKM Adapter Cables and CPU Adapter Cables typically cannot meet. For these applications, you should use coaxial cables that can carry video signals not only farther but also at higher resolutions. See Appendix B and the Caution notice on page 17.

3. Installation

3.1 Quick Setup Guide

Figure 3-1 shows how to connect a CPU and a keyboard, monitor, and mouse to the ServShare. Cable connectors will vary depending on the types of equipment you are installing (see **Appendix B**). Note that you also need to attach the unit's power supply (its output cord will plug into the POWER inlet on the rear panel).

Figure 3-1. Connecting equipment to a ServShare (4-port unit shown).

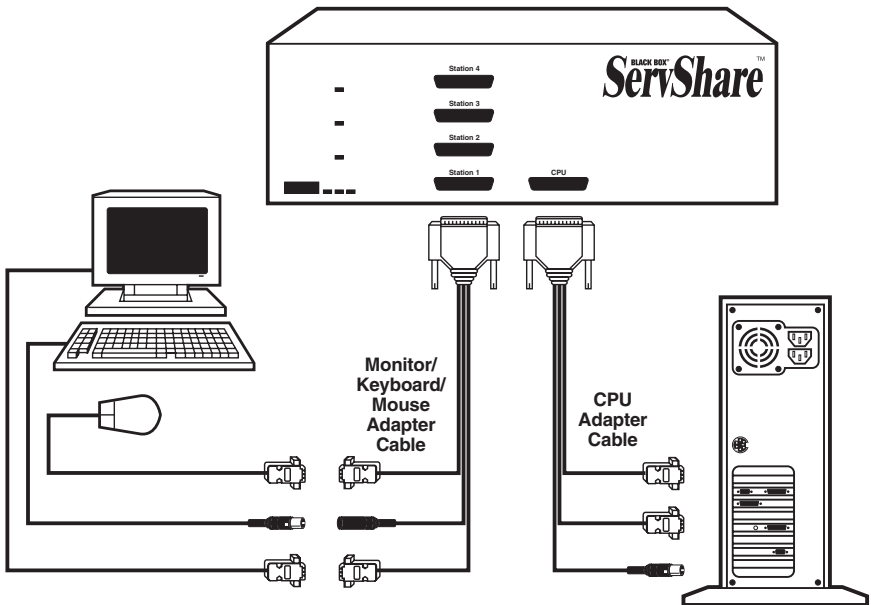

3.2 Installation Procedure

This section provides complete instructions for the hardware setup of a single ServShare. For an illustrated example of the elements of a basic setup, see Figure 3-1 on the previous page.

3.2.1 RACKMOUNTING (OPTIONAL)

If you want to mount the ServShare in a 19" rack, you will need a "classic chassis" ServSwitch Rackmounting Kit. For the 2-port (KV752 model) ServShare, you'll need a "mini" kit (our product code SW727); for the 4-port (KV754 model) ServShare, you'll need a "full-size" kit (our product code SW728). Once you have the Kit, see **Appendix C** for instructions. If you want to mount the ServShare in a 23" or 24" rack, call Black Box Technical Support for a special quote on an appropriate kit.

3.2.2 CONNECTING THE CPU

A CPU Adapter Cable runs from the ServShare to the keyboard port, mouse port, and video-output port of the CPU you want to directly attach to it. Different types of this cable fit the connectors on different computers (see **Appendix B**). This cable also comes in the different lengths supported by different applications (see **Section 4.1.3**).

CAUTION!

Avoid routing cable near fluorescent lights, air-conditioning compressors, or machines that may create electrical noise. Total length of original Serv cable from the keyboards, monitors, and mice to the CPU should not exceed 40 ft. (12.2 m). For typical equipment and video resolutions, length of coaxial cable should not exceed 20 ft. (6.1 m) from a ServShare to any attached device (keyboard, monitor, mouse, or CPU). However, we do provide coaxial cable in lengths up to 100 ft. (30.5 m), because some CPUs can drive and receive keyboard and mouse signals at greater distances than others. To go even farther, you might want to use Station Extenders (see Appendix B).

1. After you verify that the ServShare is turned off and unplugged, plug the DB25 male connector of the CPU Adapter Cable into the CPU port on the ServShare's rear panel.
2. Plug the CPU Adapter Cable's video-, keyboard-, and mouse-port connectors into the corresponding ports on the CPU. The CPU should be OFF when you do this; the ServShare will automatically adjust to the CPU's keyboard mode when you power up the CPU. Avoid plugging CPUs into the ServShare if they are already ON; if you accidentally do so, see **Section 4.4.3** to make sure the ServShare is set for the proper keyboard mode.)

CAUTION!

Do not attach a docking station for a ThinkPad® or other portable computer, no matter what type or make, to the ServShare. At the time of this writing, it does not support docking stations; your Serv system might not function properly if any are attached.

Even if you connect your ThinkPad directly (rather than through a docking station) to the keyboard, video, and mouse feeds from the ServShare, it still won't work, because the ServShare currently supports only "stream mode" (continuous) mouse data but the ThinkPad has to see "prompt mode" (burst-on-request) mouse data.

3.2.3 CONNECTING THE MONITORS, KEYBOARDS, AND MICE

Monitor/Keyboard/Mouse (MKM) Adapter Cables connect your monitors, keyboards, and mice to the ServShare. Because various styles of electrical connectors are used by different classes of equipment, we supply this cable in various styles to match (see **Appendix B**). This cable also comes in the different lengths supported by different applications (see **Section 4.1.3, Appendix B**, and the Caution notice on the previous page).

CAUTION!

Make very sure that the monitors, keyboards, and mice you plan to use can meet the demands of your application—see Section 4.1. Also, note that the ServShare doesn't support dongles.

1. After you verify that the ServShare is turned OFF, plug the DB25 male connector of the first MKM Adapter Cable into the port labeled Station 1 on the ServShare's rear panel. (Be aware that user station 1 is the "primary" or "administrator" station; it is the only user station from which the ServShare will accept keyboard-timeout and mouse-translation commands. Refer to **Sections 4.4.2 and 4.4.5**.)
2. Plug the cables from Station 1's monitor, keyboard, and mouse into the corresponding connectors on the other ends of the MKM Adapter Cable.
3. Repeat steps 1 and 2 for your remaining user station(s).

3.2.4 POWERING UP THE SYSTEM

Plug in and turn ON the ServShare, then power up the connected CPU. The ServShare emulates all keyboard and mouse functions for automatic boot-up, although you might have to issue the Mode command **Mn** (see **Section 4.4.3**) to get proper keyboard communication.

Once everything is up and running, give the system a quick test. You should be able to see the video image from the shared CPU on all of the user-station monitors. You should initially be able to type and move the mouse at any user station, but once you begin typing at any station, all other stations should be locked out. Once you finish typing and the factory-default keyboard timeout of two seconds expires (see **Section 4.4.2**), a user at another station should be able to access the CPU again.

If everything seems to work OK, your ServShare should now be ready for operation using its default settings. To take full advantage of the ServShare's features, refer to **Chapter 4**, which gives detailed information about each of the ServShare commands, describing each command's function and keystroke sequence. For your convenience, this information is summarized in **Section 4.3**.

4. Operation

The first part of this chapter, **Section 4.1**, gives you some guidelines that you should follow to make sure your ServShare works properly with your equipment. **Section 4.2** tells you how to set the ServShare's configuration DIP switch. **Section 4.3** summarizes the ServShare's keyboard commands, and **Section 4.3** describes these commands in detail.

NOTES

To start any ServShare keyboard command, you must press and release the right Control Key ([CTRL]). Pressing and releasing [CTRL] cues the ServShare to expect command characters from that keyboard. You then have two seconds in which to start entering a valid command. If no command is begun within two seconds or if an invalid command is entered, the ServShare aborts the command.

When entering commands that contain numbers or math symbols, use only the numeral keys located at the top of your alphanumeric keyboard. Numbers and symbols entered from the numeric keypad to the right will not be recognized as valid.

4.1 Guidelines for Using the ServShare with Your Equipment

4.1.1 CPU

Use only an IBM PC/AT or PS/2 or 100% compatible machine. The ServShare does not support IBM PC/XT™ or compatible machines. It also does not support machines that output CGA or EGA video.

4.1.2 MICE AND KEYBOARDS

When you power up your ServShare system, make sure that your CPU, mice, and keyboards are properly cabled to the ServShare. Unless it's absolutely necessary, don't disconnect and reconnect a mouse or keyboard from a ServShare while the ServShare is ON; if you have to do this, issue the Reset command ([CTRL] R—see **Section 4.4.8**) after you reconnect the mouse or keyboard.

The mouse must be a 2-button PS/2 or RS-232 type mouse by Microsoft or Logitech™.

Use only the generic Microsoft mouse driver MOUSE.COM, version 4.0 at least and preferably version 9.01 or higher. If you're running Windows®, this driver must be loaded in Windows as well as in the base operating system. Do not, on the shared CPU, run any programs or TSRs, or enter any DOS commands, that change the settings of the mouse port after the driver has been loaded.

The ServShare is designed to support IBM PC compatible 101-key keyboards and IBM PC keyboard-scan modes 1, 2, and 3, and it's designed to work with a CPU and keyboards that use 5-pin DIN or 6-pin mini-DIN keyboard connectors. The ServShare might not work properly with keyboards that have proprietary keys or connectors or use proprietary keyboard-scan modes.

Because the ServShare currently only supports “stream mode” (continuous) mouse data but the IBM ThinkPad has to handle mouse data in “prompt mode” (burst-on-request), don't try to attach any ThinkPad computers to the ServShare, either directly or through docking stations.

Although the ServShare resists minor transient surges that can be caused by rapidly cycling power, certain keyboards are sensitive to such transients. Because your shared keyboards get their power through the ServShare, wait at least three seconds after turning off the ServShare before turning it on again, or the keyboards might not reset correctly.

4.1.3 MONITORS

NOTE

At resolutions up to 800 x 600, the video quality for most ServShare applications will be excellent. At higher resolutions, however, you might see a little fuzziness on your monitor no matter how close to ideal your ServShare system is.

The ServShare is designed to support standard VGA video, including VGA monochrome and VGA “page white.” It does not support PCs that use CGA, EGA, or proprietary versions of VGA that depart from the original specifications. Consult your PC's manual, and if that doesn't tell you whether or not the PC uses standard VGA, consult with the PC's or the video card's manufacturer.

The ServShare is also designed to support SVGA, although we recommend coaxial cabling for this, especially for higher resolutions. With coaxial cables, the ServShare will also support XGA.

(continued on next page)

The ServShare will support SVGA (Super VGA) video, but with original Serv cables the video quality will decrease markedly at higher resolutions and distances. Table 4-1 illustrates this. The distances in the table are total cable lengths measured from the CPU to the monitor.

Table 4-1. Video Quality vs. Distance for Original Serv Cables

Resolution \ Distance	5' (1.5 m)	10' (3 m)	15' (4.6 m)	20' (6.1 m)	25' (7.6 m)
640 x 480	3	3	3	3	3
800 x 600 noninterlaced	3	3	3	2	2
1024 x 768 interlaced	3	3	2	2	2
1024 x 768 noninterlaced	3	2	2	2	2
1280 x 1024 interlaced	2	1	1	1	1
1280 x 1024 noninterlaced	2	1	1	1	1

Quality **3** = Near perfect; screen defects are not conspicuous

Quality **2** = Good to very good; images are clear; there are small reflections around text lettering depending on the color; screen defects are sometimes conspicuous

Quality **1** = Fair to poor as distance increases; images run from slightly fuzzy to badly smeared; text runs from fuzzy but readable to completely washed out

By contrast, coaxial cables (required for XGA applications, and recommended for most other applications) do much better at maintaining video quality, as shown in Table 4-2. (For the meaning of quality numbers **3**, **2**, and **1**, see the bottom of page 22.) As before, the distances in the table are total cable lengths measured from the CPU to the monitor.

Table 4-2. Video Quality vs. Distance for Coaxial Cables

Resolution \ Distance	10 ft. (3 m)	20 ft. (6.1 m)	30 ft. (9.1 m)	50 ft. (15.2 m)	75 ft. (22.9 m)	100 ft. (30.5 m)	150 ft. (45.7 m)	200 ft. (61 m)
640 x 480	3	3	3	3	3	3	2	2
800 x 600 noninterl.	3	3	3	3	3	3	2	2
1024 x 768 interlaced	3	3	3	3	3	3	2	2
1024 x 768 noninterl.	3	3	3	3	2	2	2	1
1280 x 1024 interlaced	3	2	2	2	2	1	1	1
1280 x 1024 noninterl.	3	2	2	1	1	1	1	1

CAUTION!

Some CPUs can't drive or receive keyboard and mouse signals across longer runs of coaxial cable. Consult with the manufacturers of your CPU before installing this cable in lengths greater than 20 ft. (6.1 m).

For CPU-to-monitor distances over 200 feet (61 m), Station Extenders might be required. Call Black Box Technical Support to discuss this option.

4.2 Setting the Configuration DIP Switch

In some situations, you might want to keep users at one or more of the user stations from sending keyboard commands to the ServShare. If this is true for you, you can disable command recognition for any station by setting the ServShare's configuration DIP switch. Switch position 8 (the rightmost position) controls whether the ServShare responds to commands from station 1; position 7 (2nd from right) controls response for station 2; and on 4-port models, position 6 (3rd from right) controls response for station 3 and position 5 (4th from right) controls response for station 4. Set a switch position UP to *enable* command recognition for that station or DOWN to *disable* command recognition.

The unused switch positions are reserved for future capabilities. Don't move them.

4.3 Keyboard-Command Summary

Table 4-3 on the next two pages summarizes the commands that can be sent to the ServShare. To enter any command at a user station's shared keyboard, first press and release the right Control Key, represented by "[CTRL]." (This cues the ServShare to look for commands from that keyboard.) Then enter the command followed by any arguments you wish to specify (the port number, for example).

Letter commands are not case-sensitive; they are all shown in uppercase for clarity only. In fact, you must *not* use the Shift key when you enter these commands, although it's OK if Caps Lock is on.

When you enter numeric commands or arguments, use only the numbered keys at the top of your alphanumeric keyboard. Numbers entered from the numeric keypad to the right will not be recognized as valid commands.

All of these commands have a two-second timeout between characters. This means that if you begin entering a command, but you stop for more than two seconds at any time before you type the final character, the command is aborted and the ServShare returns to normal operation. This keeps the ServShare from getting stuck waiting for you to finish the command.

The [CTRL] character is always passed through to the CPU. The command characters and operands, however, are absorbed by the ServShare and are not sent to the CPU.

Many of these commands have factory-default values (see **Appendix A**) that can be reloaded if your ServShare becomes badly misconfigured; see **Section 6.1**.

Table 4-3. The ServShare's Keyboard Commands

Command	Keystroke Sequence	Description
Keep Settings	[CTRL] K	Enter this command after you enter any of the following five commands (it saves new settings to nonvolatile memory):
Set Keyboard Timeout	[CTRL] Hxxx (xxx = a 1- to 3-digit time in seconds from 0 to 254; 255 disables the timeout)	<i>From Station 1 only:</i> Determines how long a user station's keyboard must be inactive before another station can begin accessing the CPU.
Set Keyboard Mode	[CTRL] Mx [ENTER] (x = 1, 2, or 3)	Tells the ServShare the keyboard mode (1, 2, or 3) of the CPU.
Set Keyboard Typematic	[CTRL] Axxx [ENTER] (xxx = a decimal value from 0 to 127)	Sets the keyboard typematic (automatic key-repeat) function for your user station. This command works only if the CPU is designed to use a standard keyboard and has CMOS that allows users to program the typematic function.
Set Mouse Translation	[CTRL] Qx [ENTER] (x = 0, 1, or 2)	<i>From Station 1 only:</i> Q1 turns on PS/2 to RS-232 mouse translation for all user stations. Q2 turns on RS-232 to PS/2 translation for all stations. Q0 turns off mouse translation for all stations (mouse type is autodetected).
Set Video-Blanking Delay	[CTRL] Vxxx [ENTER] (xxx = delay in seconds)	Sets the time of inactivity, in seconds, after which the ServShare will blank the screen of your station's monitor. (The monitor is reactivated when you move your mouse or press a key on your keyboard.)
Enable Other Stations	[CTRL] E	Enable the keyboard, mouse, and monitor at all other stations.
Disable Other Stations	[CTRL] D	Disable the keyboard, mouse, and monitor at all other stations.
Freeze Other Stations	[CTRL] F	Disable the keyboard and mouse at all other stations, but continue to display video.
Reset	[CTRL] R	Resets and enables the keyboard and mouse. Issue this command to correct your keyboard or mouse if one of them malfunctions or gets stuck.

Table 4-3. The ServShare's Keyboard Commands (continued)

Command	Keystroke Sequence	Description
Send Null Byte	[CTRL] N	Causes the ServShare to send a null byte to the CPU's PS/2 mouse port. Issue this command to correct the current CPU if it gets "out of sync" with the PS/2 mouse (see Section 4.3.5).
Identify ROM	[CTRL] I	Causes the ServShare to report the version of ROM it is using. Issue this command if you are asked to do so by a technical-support person.

4.4 The Commands in Detail

4.4.1 KEEP SETTINGS

The Keep Settings command saves the current state of the ServShare's keyboard-selectable settings to nonvolatile memory (NVRAM), where they become the new default (loaded at power-up) settings. To enter the command from your keyboard, press and release the right Control key, then type [K]. The five keyboard-selectable settings are described in the next five sections.

4.4.2 SET KEYBOARD TIMEOUT (FROM STATION 1 ONLY)

The ServShare resolves contention for the CPU using a timeout system: At any given time, one user station has sole access to the CPU until there is no activity on that station's keyboard for a certain timeout period. Use the Set Keyboard Timeout command (which can be issued from user station 1 only) to set this timeout period to any number of seconds from 0 to 254 (the factory-default value is 2). Entering a value of 255 completely disables the timeout; station 1 will retain access indefinitely until the value is changed. To issue the Set Keyboard Timeout command from station 1, press and release the right Control key, type [H] followed by the new timeout value (0 to 254 seconds or 255 to disable the timeout), and press [ENTER].

4.4.3 SET KEYBOARD MODE

Keyboard "modes" are electrical signaling protocols that determine how a powered CPU and keyboard interact. A CPU and keyboard must use the same mode in order to work with each other. Of the three standard keyboard modes currently in use, mode number 2 is the one used by the vast majority of CPUs. It is also the default state of all 101-key and PS/2 keyboards. Mode 1 is used primarily by certain PS/2 CPUs. Mode 3 is used by RS/6000® CPUs, some other UNIX® based computers, and certain specialized servers.

The ServShare supports all three of these modes: As it receives signals from any of the user-station keyboards, it sends them to the CPU by emulating a keyboard of the appropriate mode for that CPU; as it receives signals for one of the keyboards from the CPU, it sends them to that keyboard by emulating a CPU of the appropriate mode.

Most CPUs that use keyboard mode 1 or 3 send a "mode command" to the keyboard at power-up, to put the keyboard in the proper mode. If your CPU is a mode 1 or mode 3 type, the ServShare can use these commands to automatically detect the CPU's keyboard mode when you turn on the CPU *after* it has been cabled to the ServShare. However, the ServShare doesn't automatically save this

value; unless you send it a Keep Settings command, it will forget the mode it has detected when it is turned off or loses power, then default to the most recently saved setting when it's powered up again. (For this reason, if you're using a mode 1 or mode 3 CPU, you will probably want to change the ServShare's default keyboard mode at installation time.)

The ServShare can't detect the CPU's keyboard mode if the CPU doesn't send "mode commands" (most CPUs that use mode 2 fall into this category) or if the CPU is already ON when you connect it to the ServShare (it shouldn't be). In these situations, the ServShare tries to use the keyboard-mode setting stored in its nonvolatile memory. The factory default is mode 2. Send the Set Keyboard Mode command to change the keyboard mode if:

- the CPU uses mode 1 or 3,
- it uses mode 2, but the ServShare's default keyboard-mode setting was changed previously, or
- you don't know which mode the CPU uses or the port is set for, but the keyboard's behavior makes you suspect that the port's setting is wrong.

To set the ServShare's keyboard mode, press and release the right Control key, type [M], and press the numeral key of the mode number ([1], [2], or [3]). After you enter this command, enter the Keep Settings command to save the mode setting in NVRAM, so that the new setting becomes the default value (preserved during power-down and reloaded at power-up).

4.4.4 SET KEYBOARD TYPOMATIC

Most keyboards have an internal seven-bit “typematic” setting, which governs the way the keyboard responds when you hold a key down to force it to repeat. The five “low” bits of this setting represent the rate at which the key repeats; the two “high” bits represent the delay after you begin holding down the key before it begins to repeat. Sometimes a keyboard’s typematic setting isn’t suitable for a given operator or for a given application. To change the typematic setting of your station’s keyboard, issue the Set Keyboard Typematic command: Press and release the right Control key, type [A] followed by the desired “typematic value,” and press [ENTER]. The “typematic value” is the decimal equivalent of the binary seven-bit typematic setting: While the typematic setting = delay bits + rate bits, the typematic value = decimal delay value + decimal rate value (see Table 4-4 below and Table 4-5 on the next page). For example, to set your shared keyboard to register a key 16 times per second after the key has been held down for half a second (typematic value = 7 + 32 = 39), type [CTRL] [A] [3] [9] [ENTER]. Enter the Keep Settings command after you enter this command.

Table 4-4. Typematic Delay

Decimal Value	Binary Bit Values	Delay Before Key Repeats
0	00[xxxxx]	1/4 second (250 ms)
32	01[xxxxx]	1/2 second (500 ms)
64	10[xxxxx]	3/4 second (750 ms)
96	11[xxxxx]	1 second (1000 ms)

Table 4-5. Typematic Rate

Decimal Value	Binary Bit Values	Repeat Rate in Keys per Second
0	[xx]00000	30
1	[xx]00001	26.7
2	[xx]00010	24
3	[xx]00011	21.8
4	[xx]00100	20
5	[xx]00101	18.5
6	[xx]00110	17.1
7	[xx]00111	16
8	[xx]01000	15
9	[xx]01001	13.3
10	[xx]01010	12
11	[xx]01011	10.9
12	[xx]01100	10
13	[xx]01101	9.2
14	[xx]01110	8.6
15	[xx]01111	8
16	[xx]10000	7.5
17	[xx]10001	6.7
18	[xx]10010	6
19	[xx]10011	5.5
20	[xx]10100	5
21	[xx]10101	4.6
22	[xx]10110	4.3
23	[xx]10111	4
24	[xx]11000	3.7
25	[xx]11001	3.3
26	[xx]11010	3
27	[xx]11011	2.7
28	[xx]11100	2.5
29	[xx]11101	2.3
30	[xx]11110	2.1
31	[xx]11111	2

4.4.5 SET MOUSE TRANSLATION (FROM STATION 1 ONLY)

If the mice at all of your user stations are the same type (PS/2 or RS-232 serial) as the mouse port of your CPU, you can control the CPU from any station without having to reconfigure the system at all. But if some of your mice are not the same type as the CPU's mouse port, you might need to turn mouse translation on. (This can only be done from user station 1).

If your CPU is connected to the ServShare through a serial mouse port, but one or more of your stations have PS/2 mice, turn on PS/2 to RS-232 translation: At station 1, press and release the right Control key, type [Q][1], and press [ENTER].

If instead your CPU's mouse port is PS/2 type but there are serial mice at any of your stations, turn on RS-232 to PS/2 translation: At station 1, press and release the right Control key, type [Q][2], and press [ENTER].

To turn off mouse translation, press and release the right Control key at station 1, type [Q][0], and press [ENTER]. (This is the default setting for mouse translation.)

After you change the mouse-translation setting, enter the Keep Settings command.

4.4.6 SET VIDEO-BLANKING DELAY

This feature can reduce the wear on your monitor screen and provides security for your system by blanking the screen when there has been no activity at your user station's keyboard for a specified length of time. To set the video-blanking delay, press and release the right Control key, type [V] followed by the interval time in seconds (1 to 999, or 0 to disable video blanking at your station), and press [ENTER]. Issue the Keep Settings command after you enter this command.

To reactivate the screen when it's been blanked, press any key on the keyboard or move the mouse. The default setting of this option is 0 (video blanking disabled).

4.4.7 ENABLE, DISABLE, OR FREEZE OTHER USER STATIONS

During normal operation, the on-screen activities of the active user are visible at all user stations, and if the active user stops using the keyboard for the duration of the keyboard-timeout period (see **Section 4.4.2**), the CPU can be claimed by another user. So if active users need to remain uninterrupted for a time, they can send the Freeze Other Stations command (press and release the right Control Key, then type [F]). This will deactivate the keyboards and mice at the other stations, although the CPU's video will remain visible. If the active users also need privacy, they can send the Disable Other Stations command (press and release the right Control Key, then type [D]), which will blank the other stations' monitors as well as deactivating their keyboards and mice.

When active users are finished with their sensitive activity, they can fully re-enable the other stations by sending the Enable Other Stations command (press and release the right Control Key, then type [E]).

4.4.8 RESET

This command, along with the commands described in the next two sections, can come in handy when certain problems arise. It will reboot your station's keyboard and mouse without your having to power down the ServShare, and will also re-enable PS/2 mouse communication if the CPU has previously disabled it. (With current PCs and operating systems, this command shouldn't be necessary, but older CPUs running DOS or Windows might need it from time to time—and strange things happen even with newer machines.) Issue this command if (a) your shared keyboard gets stuck or begins behaving oddly, (b) you need to send mouse data to the CPU, but it hasn't enabled the mouse (this can happen if you boot up the CPU while the ServShare is off or disconnected), or (c) while using a PS/2 type mouse, you unplug it, plug it back in, then have problems. To issue the Reset command, press and release the right Control Key, then type [R].

If you're using a PS/2 type mouse with a DOS or Windows 3.x CPU, don't issue this command if the CPU doesn't have a mouse driver loaded—many such CPUs will crash if you send them unexpected mouse data. (CPUs running UNIX or Windows 95/98/2000/NT don't have this problem.) If your shared CPU is like this, and you have chronic problems when you try to run applications that don't use the mouse but don't disable the mouse either, take these precautions:

- If you never actually use the mouse with the CPU (as would probably be the case if, for example, the CPU were a Novell® NetWare® file server), either don't plug the mouse strand of the CPU Adapter Cable into the CPU's mouse port, or don't load a mouse driver at all. If you do use the mouse, are running Windows 3.x, and sometimes exit to DOS, make sure you load a DOS mouse driver before running Windows.

- If you've loaded a DOS mouse driver and are going to use an application such as NetWare that disables the PS/2 mouse, first REM out any statements in your startup files (AUTOEXEC.BAT, etc.) that load the mouse driver, then reboot the computer to remove the mouse driver from memory. (Having the mouse driver unload itself doesn't do the job.)

4.4.9 SEND NULL BYTE (ONLY IF CPU IS USING PS/2 MOUSE PORT)

PS/2 type mice send control data to CPUs in three-byte increments. Sometimes, because of electronic transients, unusual power-up effects, or plugging and unplugging of cables from live equipment, the CPU in a ServShare system can lose one or two bytes of this control information and get "out of sync" with the shared mouse. In this situation, the mouse might seem to refuse to move the pointer or cursor, open windows for no reason, or exhibit other strange behavior. To get the CPU back in sync, send this command to tell the ServShare to send a "null byte" to the CPU's PS/2 mouse port (this has no other effect than getting the CPU "caught up"). To issue the Send Null Byte command, press and release the right Control Key, then type [N]. (If the mouse still isn't right after you issue this command, the CPU must have been two bytes out of sync. Issuing the command again should do the trick.)

The CPU will be thrown out of sync if it has a PS/2 mouse port and it's in sync when you issue this command. Issue this command two more times to get it back in sync again. This command has no effect if your CPUs are attached to the ServShare through its RS-232 mouse port.

If you have version 9.01 or higher of the Microsoft mouse driver, the CPU should never get out of sync. Contact Microsoft if you would like to upgrade your Microsoft mouse driver.

4.4.10 IDENTIFY ROM

Unfortunately, as with all complex equipment, problems might arise with your ServShare that require the assistance of technical-support personnel. One of the things technicians might want to know when they attempt to diagnose and correct your problem is the revision level of your ServShare's ROM. This command causes the ServShare to send the three-character "x.x" ROM level to the currently selected CPU as ASCII keyboard data; these characters will be echoed back to the shared monitor if you are at some type of prompt. (You *must* be at some kind of prompt or screen capable of displaying typed-in keyboard characters, or you will not see the ServShare's response.) To issue the Identify ROM command, press and release the right Control key, then type [I].

5. Troubleshooting

The first section of this chapter, **Section 5.1**, discusses some of the problems that can arise in a ServShare system and suggests possible causes and solutions. **Sections 5.2** and **5.3** discuss what's involved in calling Black Box and shipping your ServShare.

CAUTION!

We strongly recommend that you avoid opening the ServShare's cover. If for some reason you need to do this, be very careful to replace each screw in the same hole you took it from, because there are three different lengths of screws involved.

5.1 Common Problems

5.1.1 THE CPU CONNECTED TO YOUR SERVSHARE DOESN'T BOOT, AND YOU GET A KEYBOARD OR MOUSE ERROR

- A.** First make sure that the CPU is in fact connected to the ServShare and that the ServShare is receiving power.
- B.** If the ServShare is ON, make sure its keyboard and mouse settings are correct.
- C.** If the configuration is OK, check your cables. Tighten any loose connections. If the keyboard and mouse strands of the CPU Adapter Cable have been reversed, plug them into the proper ports.
- D.** If you don't find a cable error, try swapping in different keyboards and/or mice one at a time. If the problem goes away when you substitute a device, the old one might have gone bad.
- E.** If swapping input devices doesn't solve the problem, begin swapping your cables one at a time. If the problem goes away when you substitute a cable, the old cable is probably defective.
- F.** If swapping cables doesn't solve the problem, try plugging a known-good keyboard and mouse directly into the CPU. If the CPU boots, the ServShare might be defective; call Black Box.

G. If the CPU still doesn't boot, the CPU's keyboard or mouse port (or other components) might be defective. (If the CPU's Power LED doesn't light, the fuse on the CPU's motherboard might be blown.) If you still have them, plug that CPU's original monitor, keyboard and mouse into it and try again. If the CPU does *not* boot with its original equipment, something in the CPU is defective; call the CPU's manufacturer. If the CPU *does* boot, there is some kind of unusual mismatch between that CPU and the shared monitor, keyboard, or mouse; call Black Box Technical Support.

5.1.2 YOU CAN'T ENTER KEYBOARD COMMANDS

A. *If you are not currently the active user:* Is your monitor's video blank, or does someone else appear to be using the CPU? If so, the active user might have frozen or disabled the other stations (see **Section 4.4.7**). Ask them to re-enable the other stations and give you CPU control.

B. *If you are the active user:* Can you do *anything* from the keyboard? If not, the keyboard cabling has probably come loose somewhere. Reconnect it, then test the connection by typing in characters; this should cause your station's Status LED to blink more rapidly than normal.

C. The ServShare might have lost power for less than three seconds. (This can cause the keyboard to lock up.) Disconnect the keyboard and plug it back in.

D. The keyboard mode that the currently selected CPU port is set for doesn't match the mode that the CPU on that port expects. Issue the Set Keyboard Mode command to change the port's mode (see **Section 4.4.3**). Sometimes this situation can confuse the CPU or keyboard so badly that it is necessary to reboot the CPU or to reset the keyboard by unplugging it and plugging it back in.

E. For PS/2 type equipment, if the keyboard and mouse strands of the CPU cable have been reversed, plug them into the proper ports.

F. You might be using the keyboard incorrectly. Make sure to use the *right* Control key to start port-switching commands. Make sure to use the numeric keys at the top of the keyboard rather than the numeric keypad when you type in port numbers. Make sure to release the Control key before you start typing in a port number. Make sure you don't wait too long before you enter a port number. Make sure you don't accidentally hit keys such as Shift or Alt.

5.1.3 CHARACTERS THAT YOU TYPE COME UP WRONG OR MISSING

The keyboard mode that the currently selected CPU port is set for doesn't match the mode that the CPU on that port expects. See item D under **Section 5.1.2**.

5.1.4 YOUR MOUSE DRIVER DOESN'T LOAD

A. What type of mouse are you using? If it's an RS-232 serial mouse, see steps B and D. If it's a PS/2 mouse, see steps C and D. If it's a Microsoft BallPoint mouse, see step D. At the time of this writing, the ServShare does not support other types of mice.

B. RS-232 serial mouse: Make sure that you're using the right COM port, and that the mouse driver is looking for the correct port.

C. PS/2 mouse: To recognize the mouse, the CPU must be directly connected to it, or indirectly connected to it through the ServShare, at boot-up time. Make sure that all cables are properly seated and that the ServShare is receiving power, then reboot the CPU.

D. Your mouse driver might be old or incompatible with your mouse. Try the latest version of the Microsoft mouse driver.

5.1.5 YOU CAN'T ACCESS ALL THE FUNCTIONS OF YOUR MOUSE

A. What type of mouse is it? If it is any other type than those listed as being supported in item A under **Section 5.1.4**, chances are that the ServShare doesn't support it.

B. If your mouse is a Microsoft BallPoint, you need the latest version of the Microsoft mouse driver.

C. If your mouse is a Logitech mouse, the ServShare supports the two-button models but not the three-button models.

5.1.6 YOUR PS/2 MOUSE GETS OUT OF SYNC

First try sending the Reset command (see **Section 4.4.8**). If that doesn't work, cabling might have been disturbed during mouse movement. Issue the Send Null Byte command (see **Section 4.4.9**) once or twice to get the mouse back in sync. You need the latest version of the Microsoft mouse driver to stop this from happening.

5.1.7 YOUR MOUSE DOESN'T MOVE THE POINTER/CURSOR

A. *If you are not currently the active user:* Is your monitor's video blank, or does someone else appear to be using the CPU? If so, the active user might have frozen or disabled the other stations (see **Section 4.4.7**). Ask them to re-enable the other stations and give you CPU control.

B. *If you are the active user:* Can you do *anything* with the mouse? If not, the mouse cabling has probably come loose somewhere. Reconnect it, then test the connection by moving the mouse; this should cause your station's Status LED to blink more rapidly than normal.

C. What type of mouse is it? If it is any other type than those listed as being supported in item A under **Section 5.1.4**, chances are that the ServShare doesn't support it.

D. The mouse might not be configured properly.

E. If your mouse is a PS/2 type, it might not have been connected to the ServShare when the ServShare was powered up. It might also have been disconnected and reconnected after the ServShare was powered up.

F. If your CPU is PS/2 compatible, the keyboard and mouse strands of the CPU cable might have been reversed; plug them into the proper ports.

G. Your mouse must be connected to a the ServShare when the CPU is booted and when mouse applications are run. Try exiting and re-entering your application; if this doesn't work, issue the Reset command (see **Section 4.4.8**).

5.1.8 YOUR MONITOR DISPLAY IS BLANK OR FUZZY

A. *If you are not currently the active user:* The active user might have disabled the other stations (see **Section 4.4.7**). Ask them to re-enable the other stations and give you CPU control.

B. *If you are the active user:* Check the settings of your monitor, especially the sharpness control.

C. If you can't solve the problem by changing the monitor settings, you might have run cable too far; maximum distance of original Serv cable from any CPU to the ServShare is 20 ft. (6.1 m)—or less, if you are using SVGA video. You might need to upgrade from original Serv cables to coaxial cables that carry the video signal better. See **Section 4.1.3** and **Appendix B**.

5.1.9 YOUR VIDEO IS NOT SYNCHRONIZED OR IS THE WRONG COLOR

- A. Check the settings of your monitor, especially the sync or color controls.
- B. Your monitor might not be capable of synching to the selected video resolution or frequency (refresh rate). Try a lower resolution or frequency or a more powerful monitor.
- C. If the video problem is not centered on the monitor itself, check the monitor cable and the video strand of the CPU Adapter Cable. Tighten any loose connections.
- D. If no cable connectors are loose, begin swapping your cables one at a time. If the problem goes away when you substitute a cable, the old cable is probably defective.

5.1.10 YOUR VIDEO IS OK IN LOW-RESOLUTION MODE, BUT YOU CAN'T GET INTO HIGH-RESOLUTION MODE

- A. If you're using XGA, you *must* use coaxial cables (see **Section 4.1.3** and **Appendix B**).
- B. Check your video driver. It might not be set up correctly for your desired resolution.

5.1.11 THE CPU LOCKS UP WHEN YOU START WINDOWS 3.X

The usual cause of this problem is that the CPU is set to load a Logitech or other type of mouse driver when Windows starts up. Set the CPU to load the generic Microsoft mouse driver instead.

5.1.12 THE SERVSHARE DOESN'T WORK WITH YOUR DOCKING STATION

The ServShare does not support docking stations for portable computers.

5.1.13 THE SERVSHARE DOESN'T WORK WITH YOUR DONGLE-PROTECTED SOFTWARE

The ServShare does not support dongles (the devices required to be inserted into the keyboard line by some software for copy protection).

5.1.14 THE STATUS LED FLASHES STEADILY THREE TIMES A SECOND AND THE SERVSHARE DOES NOT FUNCTION AT ALL

The ServShare has a defective component and has failed its self-test. Call Black Box Technical Support to arrange to have the unit repaired or replaced.

5.2 Calling Black Box

If you determine that your ServShare is malfunctioning, *do not attempt to alter or repair the unit*. It contains no user-serviceable parts (and see the Caution notice on page 34). Call Black Box Technical Support at 724-746-5500.

Before you do, make a record of the history of the problem. We will be able to provide more efficient and accurate assistance if you have a complete description, including:

- the nature and duration of the problem;
- when the problem occurs;
- the components involved in the problem;
- any particular application that, when used, appears to create the problem or make it worse; and
- the results of any testing you've already done.

5.3 Shipping and Packaging

If you need to transport or ship your ServShare:

- Package it carefully. We recommend that you use the original container.
- If you are shipping the ServShare for repair, make sure you include its power supply and the CPU and MKM Adapter Cables you're using with it. If you are returning the ServShare, make sure you include its manual as well. Before you ship, contact Black Box to get a Return Authorization (RA) number.

Appendix A: NVRAM Factory Defaults

The table below shows, for the ServShare's saveable options, the default values stored in nonvolatile memory (NVRAM) when the ServShare is shipped from the factory. It also shows what commands or actions can change these settings for the ServShare's current operating period, as well as what commands or actions can save changed settings to NVRAM, so that they become the new defaults.

Option	Factory-Default Setting	To Change	To Save Changes
Caps/Scroll/ Num Lock	Num Lock ON (fixed)	Press the corresponding button on your keyboard	Can't be saved
Keyboard Timeout	2 seconds	At user station 1, type [CTRL] Hxxx [ENTER] (xxx = 0 to 254 seconds, or 255 to disable the timeout)	[CTRL] K
Keyboard Mode	Mode 2	Type [CTRL] Mx (x = 1, 2, or 3)	[CTRL] K
Keyboard Typematic	43 (delay of 1/2 second, rate of 10.9 characters per second)	Type [CTRL] Axxx [ENTER] (xxx = 0 to 127; see Section 4.3.12)	[CTRL] K
Mouse Translation	0 (OFF)	At user station 1, type [CTRL] Q1 [ENTER] to turn ON PS/2 to RS-232; [CTRL] Q2 [ENTER] to turn ON RS-232 to PS/2; or [CTRL] Q0 [ENTER] to turn OFF	[CTRL] K
Video-Blanking Delay	0 (video blanking disabled)	Type [CTRL] Vxxx [ENTER] (xxx = 1 to 999 seconds, or	[CTRL] K

Appendix B: Cable Product Codes

The table below and on the next page lists the product codes for all the types of cables we currently offer for use with the ServShare. The four digits that follow the dash in each product code indicate how long each cable is in feet (one foot = 30.5 cm).

For most of these cables, xxx's are shown in place of the last three digits of the product code because the cables come in several stock lengths. For original (standard) CPU and MKM adapter cables, these last three digits can be "001" (MKM cables only), "005," "010," or "020" for 1-foot (0.3-m), 5-foot (1.5-m), 10-foot (3-m) or 20-foot (6.1-m) cables respectively. For coaxial cables, these last three digits can be "005," "010," "020," "050," "075," or "100" for 5-foot (1.5-m), 10-foot (3-m), 20-foot (6.1-m), 50-foot (15.2-m), 75-foot (22.9-m), or 100-foot (30.5-m) cables respectively.

The table also lists the product codes for the Station Extenders and their cables. Depending on your equipment and the video resolution you're using, you might be able to use the Extenders to connect the ServShare to monitor/keyboard/mouse stations or CPUs as much as 200 ft. (61 m) away.

If your monitor/keyboard/mouse-sharing system has cabling requirements that can't be met by what you see here, call Black Box for a possible quote on custom cables or adapters.

Standard Monitor/Keyboard/Mouse Adapter Cables:

Monitor Type (Connector on Cable)	Keyboard Type (Connector on Cable)	Mouse Type (Connector on Cable)	Product Code
VGA (HD15 female)	IBM PC/AT (5-pin DIN female)	Serial RS-232 (DB9 male)	EHN052-0xxx
VGA (HD15 female)	IBM PS/2 (6-pin mini-DIN female)	PS/2 (6-pin mini-DIN female)	EHN054-0xxx

Coaxial Monitor/Keyboard/Mouse Adapter Cables:

Monitor Type (Connector on Cable)	Keyboard Type (Connector on Cable)	Mouse Type (Connector on Cable)	Product Code
VGA (HD15 female)	IBM PC/AT (5-pin DIN female)	Serial RS-232 (DB9 male)	EHN270-0xxx
VGA (HD15 female)	IBM PS/2 (6-pin mini-DIN female)	PS/2 (6-pin mini-DIN female)	EHN273-0xxx

Standard CPU Adapter Cables:

Video Type (Connector on Cable)	Keyboard Type (Connector on Cable)	Mouse Type (Connector on Cable)	Product Code
VGA (HD15 male)	IBM PC/AT (5-pin DIN male)	Serial RS-232 (DB9 female)	EHN048-0xxx
VGA (HD15 male)	IBM PS/2 (6-pin mini-DIN male)	PS/2 (6-pin mini-DIN male)	EHN051-0xxx

Coaxial CPU Adapter Cable:

Video Type (Connector on Cable)	Keyboard Type (Connector on Cable)	Mouse Type (Connector on Cable)	Product Code
VGA (HD15 male)	IBM PS/2 (6-pin mini-DIN male)*	PS/2 (6-pin mini-DIN male)*	EHN282-0xxx

*This cable comes with a PC/AT keyboard adapter and a serial mouse adapter.

Station Extenders:

CPU to ServShare (RS-232 Mouse): AC254A

ServShare to Station (RS-232 Mouse): AC255A

CPU to ServShare (PS/2 Style Mouse): AC257A

ServShare to Station (PS/2 Style Mouse): AC258A

Station-Extender Cables: EHN250-0zzz, where "zzz" = 050, 100, 150, or 200 for 50, 100, 150, or 200 feet (15.2, 30.5, 45.7, or 61 m) respectively

Appendix C: Rackmounting the ServShare

To mount a ServShare in a 19" equipment rack, you'll need a "classic chassis" ServSwitch Rackmount Kit. Use the "mini size" Kit (our product code SW727) for the 2-port ServShare (KV752 models); use the "full-size" Kit (our product code SW728) for the 4-port ServShare (KV754 models). (If you need a Kit like one of these for a 23" or 24" rack, call Black Box Technical Support for a special quote.)

C.1 Mounting 2-Port (KV752) Units

Each of the SW727 Kits consists of one rackmounting shelf and four screws. To use one to mount a 2-port ServShare, take the following steps, referring to Figure C-1 on the next page. (A different Serv type switch is shown in Figure C-1, but the procedure is the same.)

1. Remove the adhesive-backed rubber feet from the bottom of the ServShare.
2. Place the ServShare on the rackmount shelf.
3. The ServShare and the shelf are pre-drilled for mounting. Using the outermost pair of holes on either end of the shelf, screw the four self-threading screws included with the Kit through the bottom of the shelf and into the bottom of the ServShare.
4. Mount the entire assembly in your rack using your own screws, bolts, or cage nuts (not included).

C.2 Mounting 4-Port (KV754) Units

Each of the SW728 Kits consists of two rackmounting "ears" and four screws. To use one to mount a 4-port ServShare, take the following steps, referring to Figure C-2 on the next page. (Again, a different Serv type switch is shown in Figure C-2, but the procedure is the same.)

1. Unscrew the two flat-head screws on each side of the ServShare.
2. Place the kit's rackmount ears against each side of the ServShare, lining up the pre-drilled holes on the ears with the holes on the box where you just removed the screws.
3. Screw the screws back into the ServShare, securing the ears to its sides.
4. Mount the entire assembly in your rack using your own screws, bolts, or cage nuts (not included).

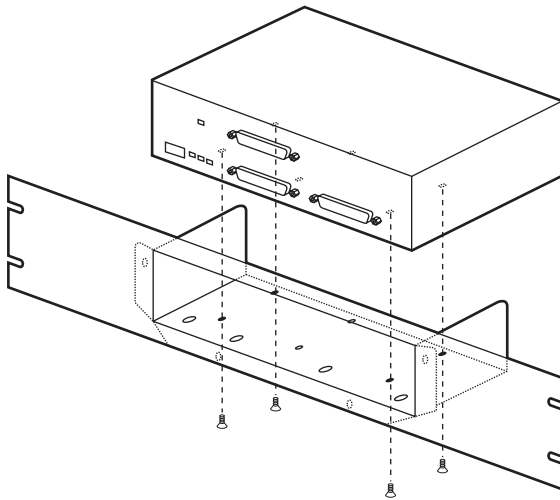

Figure C-1. Mounting a 2-Port ServShare with the SW727 Kit.

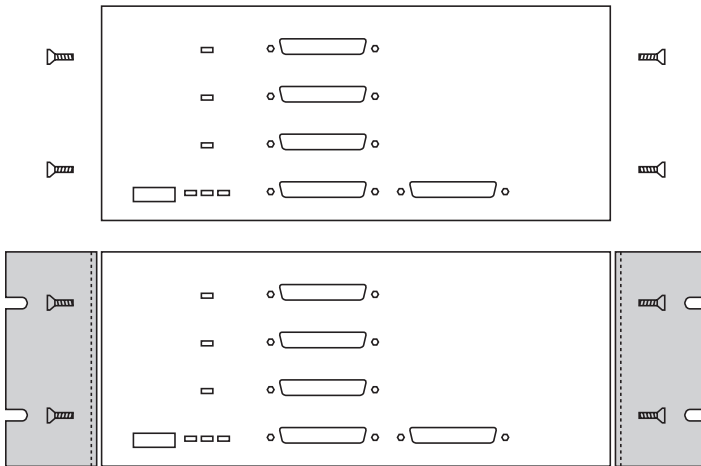

Figure C-2. Mounting a 4-Port ServShare with the SW728 Kit.

NOTES

NOTES