

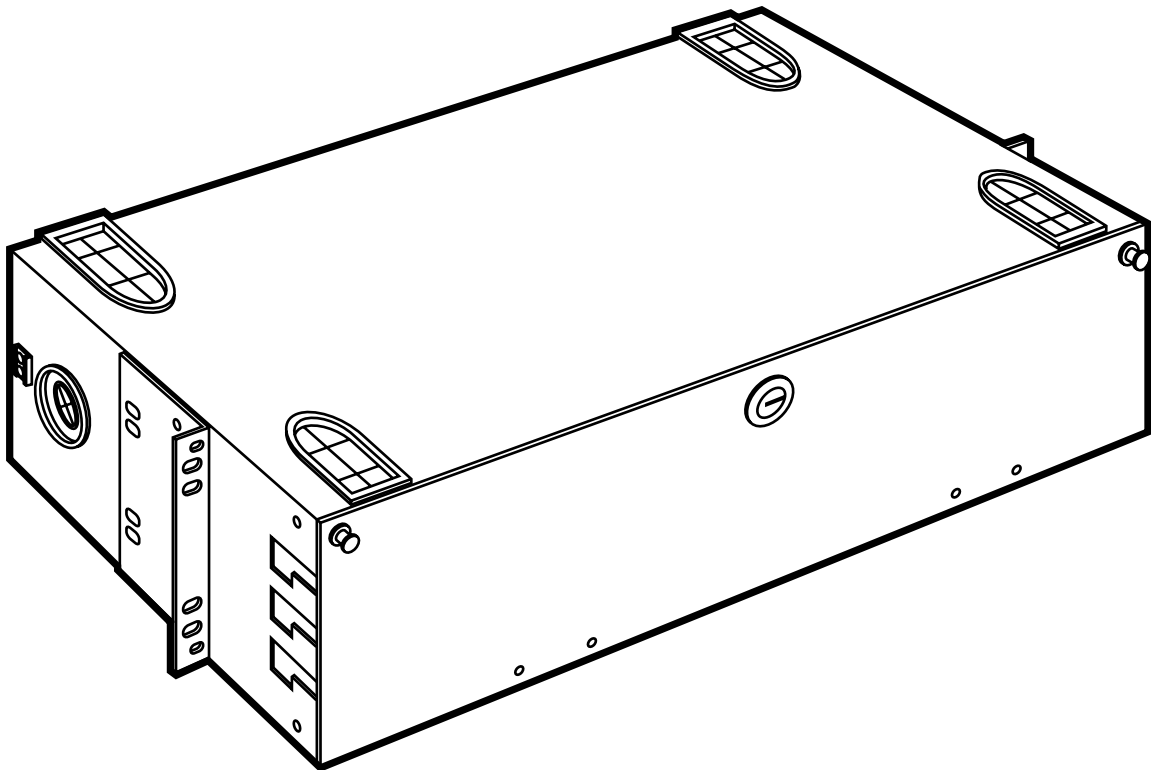

# Fiber Rackmount Cabinet



---

**CUSTOMER  
SUPPORT  
INFORMATION**

Order **toll-free** in the U.S.: Call **877-877-BBOX** (outside U.S. call **724-746-5500**)  
FREE technical support 24 hours a day, 7 days a week: Call **724-746-5500** or fax **724-746-0746**  
Mailing address: **Black Box Corporation**, 1000 Park Drive, Lawrence, PA 15055-1018  
Web site: [www.blackbox.com](http://www.blackbox.com) • E-mail: [info@blackbox.com](mailto:info@blackbox.com)

# 1. Specifications

**Construction:** 16 AWG cold-rolled steel

**Size:** JPM406A-R3: 5.25"H (3U) x 17"W x 11.5"D (13.3 x 43.2 x 29.2 cm);  
JPM418A-R2: 3.5"H (2U) x 17"W x 11"D (8.9 x 43.2 x 27.9 cm)

**Weight:** JPM406A-R3: 15.5 lb. (7 kg);  
JPM418A-R2: 15 lb. (6.8 kg)

## 2. Overview

The JPM406A-R3 is 3U high, fits in a 19" or 23" rack, and supports 12 adapter panels. (Each adapter panel has up to 12 connectors, for a maximum of 144 ports.) It provides termination for optical cables on the premises or in a central office. The JPM418A-R2 is only 2U high and supports 6 adapter panels; it also fits in a 19" or 23" rack. (Each adapter panel has up to 12 connectors, for a maximum of 72 ports.)

The Fiber Rackmount Cabinets are constructed of 16-gauge cold-rolled steel, and they're compact and rugged enough for commercial applications. Its powder coating finish is corrosion resistant.

The cabinet has front, back, and side access points for testing, removing, adding fiber, or replacing modular adapters. The adapter panels mount on the adapter bracket from the front of the chassis.

Two cable-entry holes at the right and left on the cabinet's rear and two patch cord exit holes in the front bottom make cable installation easy.

The cabinet has a front door, a rear door, and outside and inside plant cable entry/exit holes. Up to 3 splice trays (JPM440A, not included) can be mounted in the chassis. One splice tray accepts four fusion (for single-mode fiber) or four mechanical (for multimode fiber) splice modules.

Your package should include the following items. If anything is missing or damaged, please contact Black Box at 724-746-5500.

- (1) Fiber Rackmount Cabinet
- (4) 1 $\frac{1}{2}$ " cup-head screws
- (30) 3" (7.6-cm) cable ties
- (6) rectangular plastic cable holders
- (1) "danger" sticker
- (1) locking PLEXIGLAS® door
- (4) silver screws for mounting
- (4) washers for mounting
- (1) Kevlar® clamp (installed)
- (4) 1 $\frac{1}{2}$ " cup-head screws
- (4) 4" (10.2-cm) cable ties
- (3) black spool rings (installed) for JPM406A-R3 or  
(2) black spool rings (installed) for JPM418A-R2
- (2) mounting brackets
- (1) set of keys
- (1) users' manual

# 3. Installation

1. Attach the two mounting brackets to the cabinet, and secure them with the four silver screws and four washers.
2. Using the  $\frac{1}{2}$ " or  $\frac{1}{4}$ " cup-head screws, mount the Fiber Rackmount Cabinet in a 19" or 23" rack.
3. Open the back door by pulling, then releasing, the locking buttons.
4. Route multi-strand fiber cable (not included) through the rubber grommets on the cabinet's top, bottom, or side.
5. Use the Kevlar clamp to secure the multi-strand fiber to the cabinet. Loosen the Kevlar clamp's two screws and wrap the cable's Kevlar yarn around the clamp. Tighten the screws to secure the multi-strand fiber to the cabinet.

## NOTE

**The Kevlar clamp can be mounted on the cabinet's rear left or right.**

6. Install the cabinet's PLEXIGLAS front door.
7. Pull out the tray (see Figure 1) to install a fiber adapter and splice tray (if needed). Up to 12 fiber adapters can be installed in the JPM406A-R3; up to 6 can be installed in the JPM418A-R2.
8. Install the connectors on the multi-strand fiber cable, or make the splice as needed. (See Figure 2 for a typical cable installation.) Connect the fiber cable to the fiber adapters.
9. Use the included rectangular plastic cable holders, cable ties, and black spool rings to hold the cable in place inside the cabinet.
10. Slide the tray back into place inside the cabinet.
11. Close the cabinet's rear door.
12. Snap in the 1" (2.5-cm) rectangular cable holder in the front of the inside tray. This helps organize the fiber patch cables used in the front of the cabinet.
13. Close the cabinet's front PLEXIGLAS door. Push the buttons in, then release, to lock.
14. Attach the "danger" sticker to the cabinet's rear or top panel.

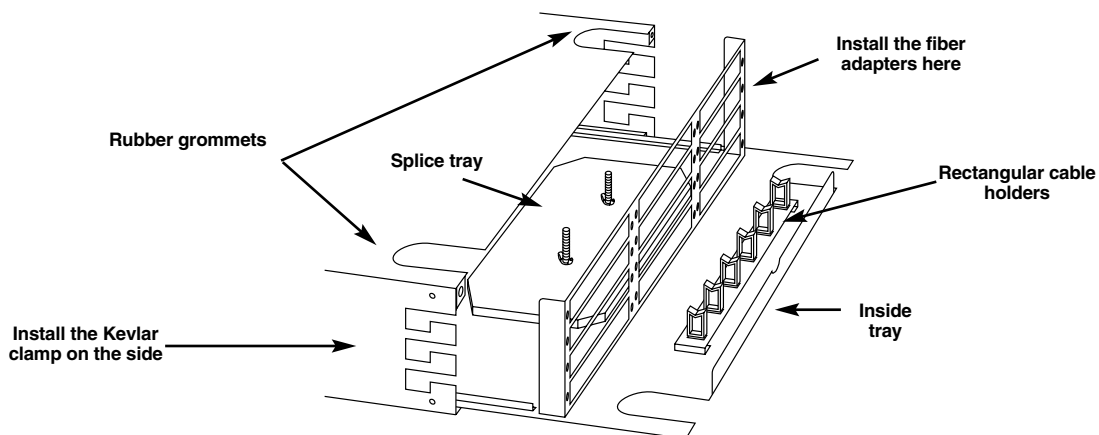

**Figure 1. Fiber Rackmount Cabinet with tray pulled out.**

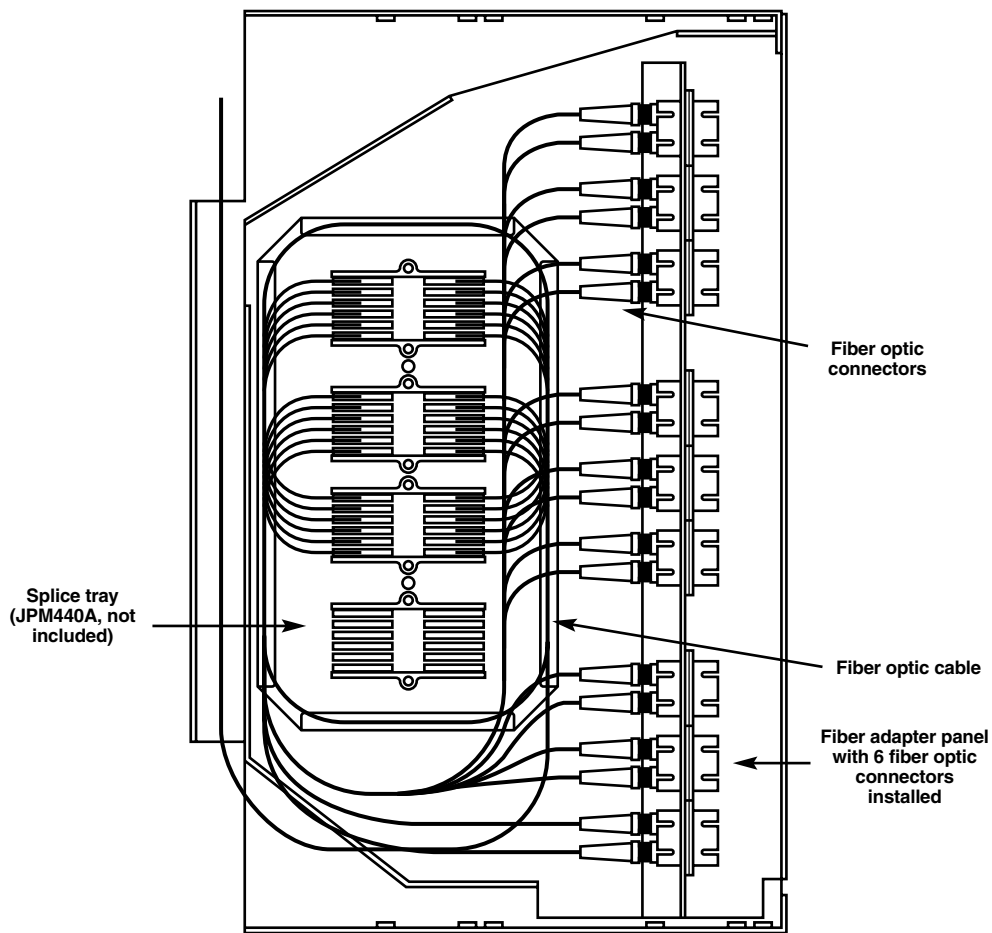

**Figure 2. Cabinet with three fiber adapter panels visible (up to nine more can be stacked beneath the visible ones, for a total of 12 adapter panels). The fiber cable is routed through the splice tray, then terminated via the fiber optic connectors.**

**TRADEMARKS USED IN THIS MANUAL**

Kevlar is a registered trademark of E.I. du Pont de Nemours and Company.

PLEXIGLAS is a registered trademark of Roehm GmbH & CO.

*Any other trademarks mentioned in this manual are acknowledged to be the property of the trademark owners.*

© Copyright 2005. Black Box Corporation. All rights reserved.