

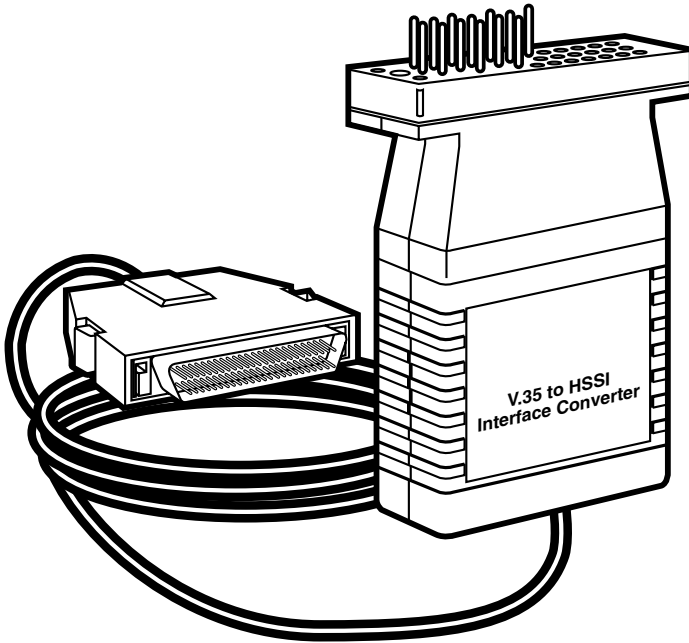

V.35↔HSSI Interface Converters



**CUSTOMER
SUPPORT
INFORMATION**

Order toll-free in the U.S.: Call **877-877-BBOX** (outside U.S. call **724-746-5500**)
FREE technical support 24 hours a day, 7 days a week: Call **724-746-5500** or fax **724-746-0746**
Mailing address: **Black Box Corporation**, 1000 Park Drive, Lawrence, PA 15055-1018
Web site: www.blackbox.com • E-mail: info@blackbox.com

**FEDERAL COMMUNICATIONS COMMISSION
AND
INDUSTRY CANADA
RADIO FREQUENCY INTERFERENCE STATEMENTS**

This equipment generates, uses, and can radiate radio-frequency energy, and if not installed and used properly, that is, in strict accordance with the manufacturer's instructions, may cause interference to radio communication. It has been tested and found to comply with the limits for a Class A computing device in accordance with the specifications in Subpart B of Part 15 of FCC rules, which are designed to provide reasonable protection against such interference when the equipment is operated in a commercial environment. Operation of this equipment in a residential area is likely to cause interference, in which case the user at his own expense will be required to take whatever measures may be necessary to correct the interference.

Changes or modifications not expressly approved by the party responsible for compliance could void the user's authority to operate the equipment.

This digital apparatus does not exceed the Class A limits for radio noise emission from digital apparatus set out in the Radio Interference Regulation of Industry Canada.

Le présent appareil numérique n'émet pas de bruits radioélectriques dépassant les limites applicables aux appareils numériques de la classe A prescrites dans le Règlement sur le brouillage radioélectrique publié par Industrie Canada.

**NORMAS OFICIALES MEXICANAS (NOM)
ELECTRICAL SAFETY STATEMENT****INSTRUCCIONES DE SEGURIDAD**

1. Todas las instrucciones de seguridad y operación deberán ser leídas antes de que el aparato eléctrico sea operado.
2. Las instrucciones de seguridad y operación deberán ser guardadas para referencia futura.
3. Todas las advertencias en el aparato eléctrico y en sus instrucciones de operación deben ser respetadas.
4. Todas las instrucciones de operación y uso deben ser seguidas.
5. El aparato eléctrico no deberá ser usado cerca del agua—por ejemplo, cerca de la tina de baño, lavabo, sótano mojado o cerca de una alberca, etc..
6. El aparato eléctrico debe ser usado únicamente con carritos o pedestales que sean recomendados por el fabricante.
7. El aparato eléctrico debe ser montado a la pared o al techo sólo como sea recomendado por el fabricante.
8. Servicio—El usuario no debe intentar dar servicio al equipo eléctrico más allá a lo descrito en las instrucciones de operación. Todo otro servicio deberá ser referido a personal de servicio calificado.
9. El aparato eléctrico debe ser situado de tal manera que su posición no interfiera su uso. La colocación del aparato eléctrico sobre una cama, sofá, alfombra o superficie similar puede bloquea la ventilación, no se debe colocar en libreros o gabinetes que impidan el flujo de aire por los orificios de ventilación.
10. El equipo eléctrico deber ser situado fuera del alcance de fuentes de calor como radiadores, registros de calor, estufas u otros aparatos (incluyendo amplificadores) que producen calor.
11. El aparato eléctrico deberá ser conectado a una fuente de poder sólo del tipo descrito en el instructivo de operación, o como se indique en el aparato.

12. Precaución debe ser tomada de tal manera que la tierra física y la polarización del equipo no sea eliminada.
13. Los cables de la fuente de poder deben ser guiados de tal manera que no sean pisados ni pellizcados por objetos colocados sobre o contra ellos, poniendo particular atención a los contactos y receptáculos donde salen del aparato.
14. El equipo eléctrico debe ser limpiado únicamente de acuerdo a las recomendaciones del fabricante.
15. En caso de existir, una antena externa deberá ser localizada lejos de las líneas de energía.
16. El cable de corriente deberá ser desconectado del cuando el equipo no sea usado por un largo periodo de tiempo.
17. Cuidado debe ser tomado de tal manera que objetos líquidos no sean derramados sobre la cubierta u orificios de ventilación.
18. Servicio por personal calificado deberá ser provisto cuando:
 - A: El cable de poder o el contacto ha sido dañado; u
 - B: Objetos han caído o líquido ha sido derramado dentro del aparato; o
 - C: El aparato ha sido expuesto a la lluvia; o
 - D: El aparato parece no operar normalmente o muestra un cambio en su desempeño; o
 - E: El aparato ha sido tirado o su cubierta ha sido dañada.

CE Notice

The CE symbol on this equipment indicates that it is in compliance with the Electromagnetic Compatibility (EMC) directive and the Low Voltage Directive (LVD) of the Union European (EU).

TRADEMARKS USED IN THIS MANUAL

Any trademarks mentioned in this manual are acknowledged to be the property of the trademark owners.

Contents

Chapter	Page
1. Specifications.....	6
2. Introduction	7
2.1 Description	7
2.2 Features	7
3. Configuration.....	8
3.1 Configuration Switches in the IC946A	9
3.2 Configuration Switches in the IC945A	12
4. Installation.....	15
4.1 IC946A	15
4.2 IC945A	15
4.3 AC Power Connection	16
4.4 DC Power Connection	16
5. Operation	17
5.1 Back-Panel LEDs	17
5.2 Test Modes	17
5.2.1 Local Loopback (LL)	19
5.2.2 Remote Digital Loopback (RL)	19
Appendix A: Pinouts.....	21
Appendix B: Block Diagrams	24

1. Specifications

Data Rate—	Up to 10 Mbps
Protocol—	Synchronous
Standards—	CCITT V.35; HSSI (ANSI/TIA/EIA-613)
Interfaces—	IC945A: Connects V.35 (DCE) to HSSI (DTE); IC946A: Connects V.35 (DTE) to HSSI (DCE)
Connectors—	(1) HD50 Slimline male; (1) M/34 male
Loopbacks—	Local and Remote
Clocking—	All HSSI co-directional timing patterns are supported
Cable—	6 feet (1.8 m)
Compliance—	FCC Class A, IEC CE (emissions)
Approval—	CE (EMC Directive/EN 50082-1)
Temperature Range—	32 to 122°F (0 to 50°C)
Humidity Range—	5 to 95%, noncondensing
Max. Altitude—	Up to 15,000 feet (4572 m)
Power—	Unit will require an external desktop power supply 100–240 VAC
Size—	0.8"H x 1.8"W x 3"D (2 x 4.6 x 7.6 cm)

2. Introduction

2.1 Description

The V.35↔HSSI Interface Converter allows an HSSI (HD50) device to communicate bi-directionally with a V.35 device at synchronous data rates up to 10 Mbps. The Converter supports all HSSI co-directional timing patterns, 2 loopback modes (local and remote line), full-duplex data, and control signals.

The Converter is available in two versions. The Model IC946A lets a V.35 DTE device communicate with an HSSI DCE device. The IC945A lets a V.35 DCE device communicate with an HSSI DTE device.

Both versions are equipped with a male M/34 connector on the converter end and a male HD50 on the end of a 6-foot (1.8-m) cable. Power is supplied to the Converter by an external desktop AC transformer.

2.2 Features

- Bi-directionally converts V.35 to HSSI.
- Supports synchronous data rates up to 10 Mbps.
- Transparent to synchronous protocol.
- M/34 and HD50 connectors with integral 6-foot (1.8-m) cable.
- Internal synchronization circuit enables high-speed connections.
- Externally AC powered.

3. Configuration

To use the Converter, you must first configure the unit for your application. To do so, first open the case by inserting a flat-head screwdriver into an open slot on either side of the case, as in Figure 3-1.

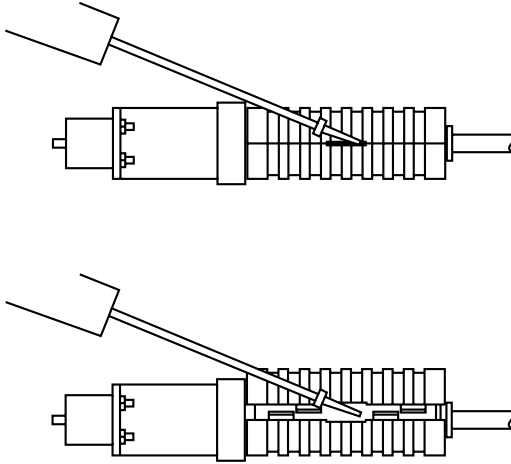

Figure 3-1. Use a small screwdriver to open the case.

Twist the screwdriver head slightly and the top half of the case will separate from the lower half. You now have access to the internal switches used to configure the unit.

After opening the case, please refer to **Section 3.1** if you purchased the IC946A and **Section 3.2** if you purchased the IC945A.

To close the case, fit the 2 halves together snugly and snap them back in place.

3.1 Configuration Switches in the IC946A

The IC946A uses a mini DIP switch that may be used to configure the unit to connect synchronous V.35 DTE equipment to synchronous HSSI DCE equipment. Each interface converter is factory-configured as DCE on the V.35 end, and DTE on the HSSI end. Therefore, the V.35 end “wants” to connect to DTE and the HSSI end “wants” to connect to DCE.

Please follow the instructions in this section to configure the internal DIP switches so that the unit will work properly in your application. Figure 3-2 shows the position of Switch S1 on the top side of the PC board.

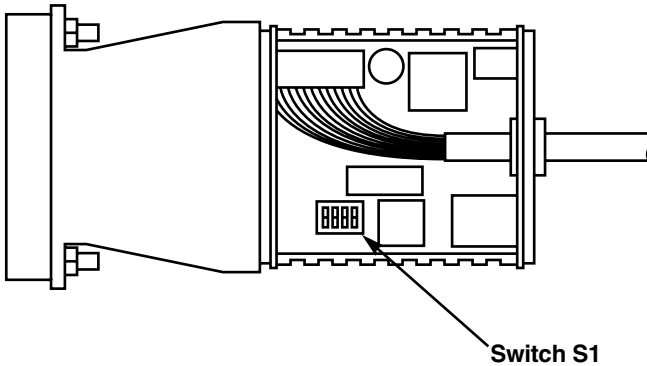

Figure 3-2. The IC946A.

Figure 3-3 shows the orientation of the switches on DIP Switch S1 with respect to ON/OFF positions. The default settings for DIP Switch S1 are shown in Table 3-1. Detailed descriptions of each switch follow the table.

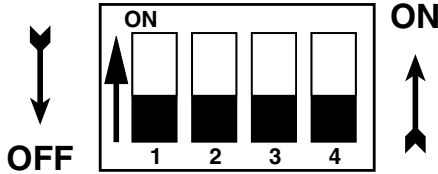

Figure 3-3. Closeup of the DIP switches.

Table 3-1. DIP-switch summary

Position	Function	Factory Default	
S1-1	Clock Source	On	HSSI ST
S1-2	Clock Source	Off	Signal
S1-3	Sync Method	Off	Bypass
S1-4	Sync Method	On	Sync Circuit

Switches S1-1 and S1-2: Clock Source

The setting for Switches S1-1 and S1-2 determines the source of the HSSI Terminal Timing (TT). With Switch S1-1 On and S1-2 Off, the IC946A derives the HSSI Terminal Timing from the ST signal provided by the HSSI DCE. With Switch S1-1 Off, and S1-2 On, the V.35 DTE provides TT to the HSSI DCE.

<u>S1-1</u>	<u>S1-2</u>	<u>Description</u>
Off	Off	Not a Valid Setting
Off	On	Terminal Timing Supplied by V.35 DTE device
On	Off	Terminal Timing supplied by HSSI ST signal
On	On	Not a Valid Setting

Switches S1-3 and S1-4: Synchronization Method

Switches S1-3 and S1-4 allow the IC946A to compensate for timing delays when transmitting HSSI data at high speeds (greater than 2.5 Mbps). At high bit rates, set Switch S1-3 On and Switch S1-4 Off. In this setting, the V.35 data will be synchronized to the SD timing signal before conversion to HSSI. At lower bit rates (less than 2.5 Mbps), set Switch S1-3 Off and S1-4 On. In this setting, the V.35 data bypasses the synchronization circuit and is passed straight through to the HSSI DCE.

<u>S1-3</u>	<u>S1-4</u>	<u>Description</u>
Off	Off	Not a Valid Setting
Off	On	Data Skips Sync Circuit
On	Off	Data passes through sync circuit.
On	On	Not a Valid Setting

3.2 Configuration Switches in the IC945A

The IC945A uses a mini DIP switch that may be used to configure the unit to connect synchronous V.35 DCE equipment to synchronous HSSI DTE equipment. Each interface converter is factory-configured as DTE on the V.35 end, and DCE on the HSSI end. Therefore, the V.35 end “wants” to connect to DCE and the HSSI end “wants” to connect to DTE.

Please follow the instructions in this section to configure the internal DIP switches so that the unit will work properly in your application. Figure 3-4 shows the position of Switch S1 on the top side of the PC board.

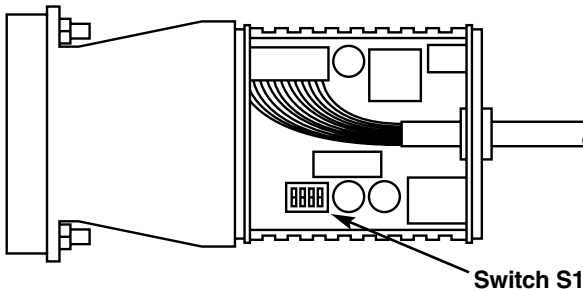

Figure 3-4. The IC945A.

Figure 3-5 shows the orientation of the Switches on DIP Switch S1 with respect to ON/OFF positions. The default settings for DIP switch S1 are shown in the Table 3-2. Detailed descriptions of each switch follow the table.



Figure 3-5. Closeup of the DIP switches.

Table 3-2. DIP-switch summary

Position	Function	Factory Default	
S1-1	Gapped Clock	On	No Gapped
S1-2	Gapped Clock	Off	Clock
S1-3	Sync Method	Off	Bypass
S1-4	Sync Method	On	Sync Circuit

Switches S1-1 and S1-2: Gapped Clock

Switches S1-1 and S1-2 allow the IC945A to generate a HSSI gapped clock. Gapped clocking is a method of flow control in which data flow is interrupted by an idle (gapped) clock signal. In this mode, the IC945A will gap the ST clock to the HSSI DTE whenever the V.35 CTS signal is de-asserted. In the “No Gapped Clock” setting, the V.35 clock passes through with only a level change.

<u>S1-1</u>	<u>S1-2</u>	<u>Description</u>
Off	Off	Not a Valid Setting
Off	On	Gapped Clock
On	Off	No Gapped Clock
On	On	Not a Valid Setting

Switches S1-3 and S1-4: Synchronization Method

Switches S1-3 and S1-4 allow the IC945A to compensate for timing delays when transmitting HSSI data at high speeds (greater than 2.5 Mbps). At high bit rates, set Switch S1-3 On and Switch S1-4 Off. In this setting, the V.35 data signals will be synchronized to the SD timing signal before conversion to HSSI. At lower bit rates (less than 2.5 Mbps), set Switch S1-3 Off and S1-4 On. In this setting, the V.35 data bypasses the synchronization circuit and is passed straight through to the HSSI DTE.

<u>S1-3</u>	<u>S1-4</u>	<u>Description</u>
Off	Off	Not a Valid Setting
Off	On	Data Skips Sync Circuit
On	Off	Data passes through sync circuit.
Off	Off	Not a Valid Setting

4. Installation

4.1 IC946A

The IC946A is designed to connect a V.35 DTE device to an HSSI DCE device. In this application, the M/34 (V.35) and HD50 (HSSI) male connectors of the IC946A may connect directly to their respective equipment ports, or they may connect via a short “straight-through” cable (see **Appendix A** for interface pin assignments). Figure 4-1 illustrates the proper connection of the IC946A.

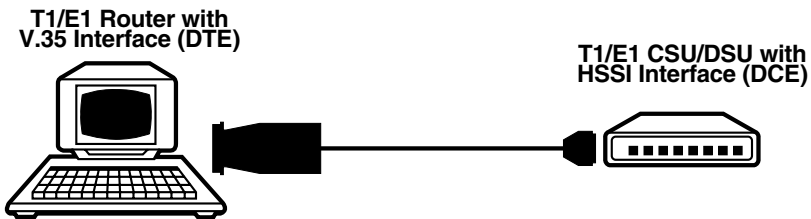

Figure 4-1. A common V.35 DTE to HSSI DCE installation.

4.2 IC945A

The IC945A is designed to connect a V.35 DCE device to an HSSI DTE device. In this application, the M/34 (V.35) and HD50 (HSSI) male connectors of the IC945A may connect directly to their respective equipment ports, or they may connect via a short “straight-through” cable (see **Appendix A** for interface pin assignments). Figure 4-2 illustrates the proper connection of the IC945A.

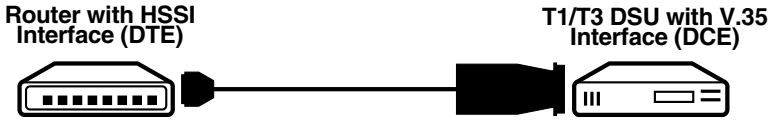

Figure 4-2. A common HSSI DTE to V.35 DCE installation.

4.3 AC Power Connection

The V.35↔HSSI Interface Converter uses a 5-VDC, 2A universal-input power supply that is equipped with a male IEC-320 power-entry connector and supports a voltage range of 100 to 240 VAC. This transformer connects to the V.35↔HSSI Interface Converter by means of a cannon jack on the rear panel. You'll need to supply a power cord for the power entry. The V.35↔HSSI Interface Converter is powered-up as soon as it is plugged into an AC outlet—there is no power switch.

4.4 DC Power Connection

You may bypass the DC wall adapter and supply DC power directly to the V.35↔HSSI Interface Converter power-supply jack. DC power supplied must be 5 VDC $\pm 5\%$, 1A minimum, center positive, and can be supplied via a barrel type plug with 2.1/5.5/10 mm I.D./O.D./Shaft Length dimensions.

NOTE

DC power source must be SELV (Circuit, Safety Extra Low Voltage) specified. (See CENELEC EN60950, Section 1.2.8.5)

5. Operation

Once you've configured the Converter properly (**Chapter 3**) and have correctly connected DTE, DCE, and power (**Chapter 4**), you're ready to operate the Converter.

5.1 Back-Panel LEDs

The Converter has two LEDs on the back panel (see Figure 5-1).

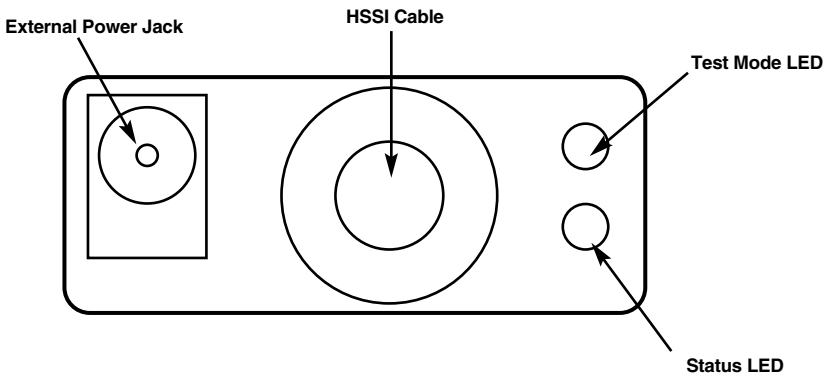

Figure 5-1. The rear panel.

- Status** Lit green to show that both DTR (from the DTE device) and DSR (from the DCE device) are active. This LED will not light whenever one of the two signals is inactive.
- Test Mode** Lit red to show that either one or both of the test modes is active (See **Section 5.2** for a description of the test modes).

5.2 Test Modes

The V.35↔HSSI Interface Converter supports two loopback modes that may be used to evaluate the condition of the communication links. These modes, Local Loopback (LL) and Remote Loopback (RL), are always initiated by the signals on the DTE device (see Figure 5-2).

NOTE

HSSI supports a third loopback mode: Local Digital Loopback (LDL). However, V.35 does not support this mode.

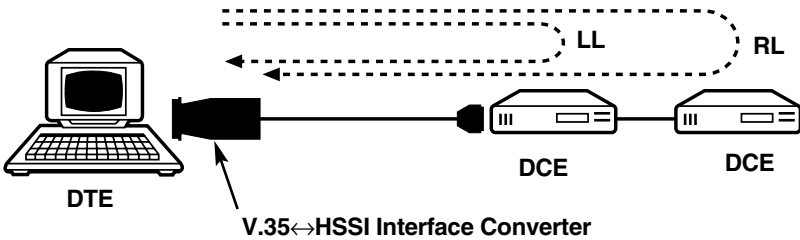

Figure 5-2. Local and remote loopback modes.

5.2.1 LOCAL LOOPBACK (LL)

The Local Loopback (LL) test checks the performance of the link between the DTE device and the DCE. Any data sent to the Converter from the DTE in this test mode will be sent to the local DCE and will then be echoed (returned) back to the DTE (the Converter simply converts and passes the data to the the local DCE, which must perform the loopback). To perform an LL test:

- A. Verify that the data terminal equipment is operating properly and can be used for a test. If a fault is indicated, call a technician or replace the unit.
- B. Activate LL from the DTE device. This may be done either by raising pin L (if the V.35 device is DTE), or by activating Local Loopback from the HSSI Interface (if the HSSI device is the DTE). The “test” LED should be lit.
- C. Perform a BER (bit error rate) test from the DTE. If the test indicates no fault, deactivate LL and proceed as normal.

5.2.2 REMOTE DIGITAL LOOPBACK (RL)

The Remote Loopback (RL) test checks the performance of the link between the DTE device and the DCE as well as the link between the local and remote DCE devices. Any characters sent from the DTE in this test mode will be sent to the local DCE, which will send the data to the remote DCE. The remote DCE should return the data back through the entire communication link and finally, to the DTE. To perform an RL test:

- A. Activate RL from the DTE device. This may be done either by raising pin N on the V.35 interface (if the V.35/RS-422 device is DTE), or by activating Local Loopback from the HSSI interface (if the HSSI device is the DTE). The “test” LED should be lit.
- B. Perform a BER (bit error rate) test from the DTE.

- C. If the BER test equipment indicates a fault, and the Local Loopback test was successful, you may have a problem with the cable between the DCE devices.

NOTE

The V.35↔HSSI Interface Converter simply converts and passes the data through the communication link. The DCEs must be configured to perform to the appropriate loopback diagnostic.

Appendix A: Pinouts

HSSI Interface HD-50 Connector (DCE or DTE)

<u>Pin #</u>	<u>Signal</u>
1	SGND (Signal Ground)
26	SGND (Signal Ground)
2	RT (Receive Timing-A)
27	RT/ (Receive Timing-B)
3	DSR/(DCE Ready-A)
28	DSR (DCE Ready-B)
4	RD (Receive Data-A)
29	RD/ (Receive Data-B)
5	Reserved for Future Use
30	Reserved for Future Use
6	ST (Send Timing-A, DCE Source)
31	ST/ (Send Timing-B, DCE Source)
7	Reserved for Future Use
32	Reserved for Future Use
8	DTR (DTE Ready-A)
33	DTR/ (DTE Ready-B)
9	TT (Terminal Timing-A, DTE Source)
34	TT/ (Terminal Timing-B, DTE Source)
10	LA (Loopback A-A)
35	LA/ (Loopback A-B)
11	SD (Send Data A)
36	SD/ (Send Data B)
12	LB (Loopback B-A)
37	LB/ (Loopback B-B)
13	Reserved for Future Use
38	Reserved for Future Use
14–18	Reserved for Future Use

HSSI Interface (continued)

<u>Pin #</u>	<u>Signal</u>
39–43	Reserved for Future Use
19	Reserved for Future Use
44	Reserved for Future Use
20–23	Reserved for Future Use
45–48	Reserved for Future Use
24	TM - Test Mode (Indication-A)
49	TM/ - Test Mode (Indication-B)
25	SGND (Signal Ground)
50	SGND (Signal Ground)

**V.35 Interface
M/34 Connector (V.35 DCE or DTE)**

<u>Pin #</u>	<u>Signal</u>
A	FGND (Frame Ground)
B	SGND (Signal Ground)
C	RTS (Request to Send)
D	CTS (Clear to Send)
E	DSR (Data Set Ready)
F	CD (Carrier Detect)
H	DTR (Data Terminal Ready)
L	LL (Local Loopback)
M	TM (Test Mode)
N	RL (Remote Loopback)
P	TD (Transmit Data)
R	RD (Receive Data)
S	TD/ (Transmit Data-B)
T	RD/ (Receive Data-B)
U	TT (Terminal Timing-A)
V	RT (Receive Timing-A)

V.35 Interface (continued)

<u>Pin #</u>	<u>Signal</u>
W	TT/ (Terminal Timing-B)
X	RT/ (Receive Timing-B)
Y	ST (Send Timing-A)
AA	ST/ (Send Timing-B)

Appendix B: Block Diagrams

Figure B-1. IC946A.

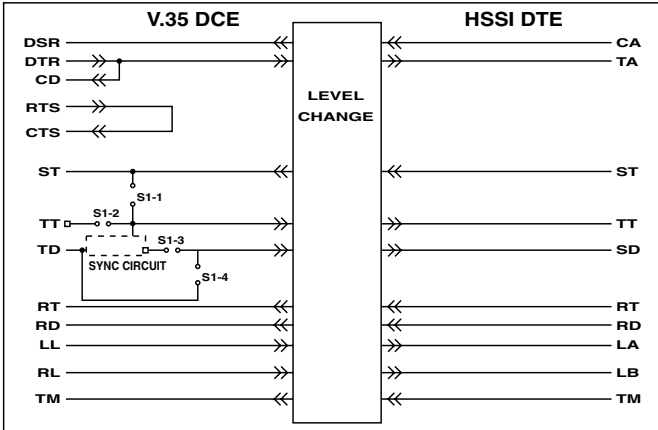
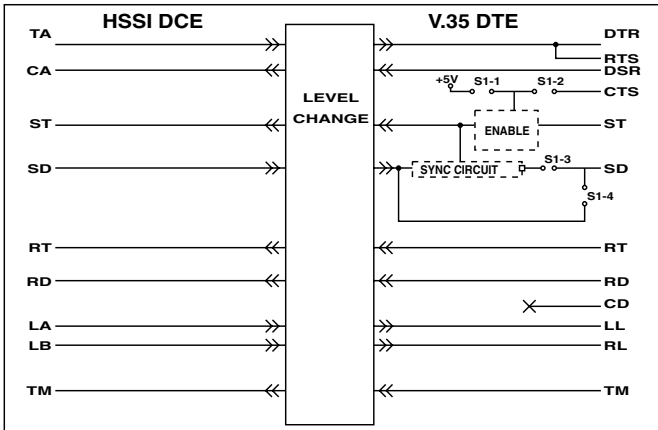

Figure B-2. IC945A.





© Copyright 1998. Black Box Corporation. All rights reserved.

1000 Park Drive • Lawrence, PA 15055-1018 • 724-746-5500 • Fax 724-746-0746