



© Copyright 1995. Black Box Corporation. All rights reserved.

---

1000 Park Drive • Lawrence, PA 15055-1018 • 724-746-5500 • Fax 724-746-0746



CL095A-F  
CL095A-M  
CL096A-F

JULY 1995  
CL096A-M  
CL097A-F  
CL097A-M

# HS RS-232↔Current Loop Converter Passive

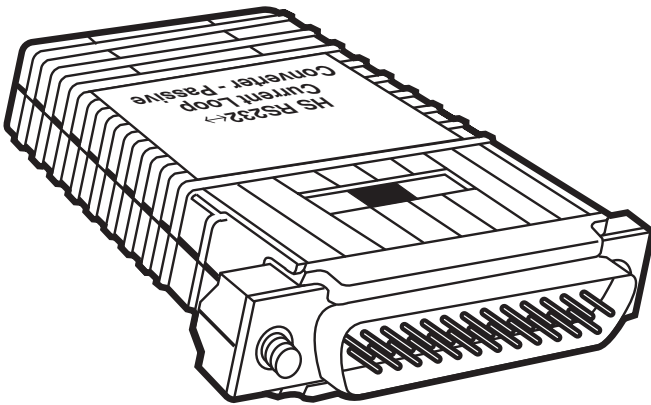

---

**CUSTOMER  
SUPPORT  
INFORMATION**

Order **toll-free** in the U.S.: Call **877-877-BBOX** (outside U.S. call **724-746-5500**)  
FREE technical support 24 hours a day, 7 days a week: Call **724-746-5500** or fax **724-746-0746**  
Mailing address: **Black Box Corporation**, 1000 Park Drive, Lawrence, PA 15055-1018  
Web site: [www.blackbox.com](http://www.blackbox.com) • E-mail: [info@blackbox.com](mailto:info@blackbox.com)

**FEDERAL COMMUNICATIONS COMMISSION  
AND  
CANADIAN DEPARTMENT OF COMMUNICATIONS  
RADIO FREQUENCY INTERFERENCE STATEMENTS**

This equipment generates, uses, and can radiate radio frequency energy and if not installed and used properly, that is, in strict accordance with the manufacturer's instructions, may cause interference to radio communication. It has been tested and found to comply with the limits for a Class A computing device in accordance with the specifications in Subpart J of Part 15 of FCC rules, which are designed to provide reasonable protection against such interference when the equipment is operated in a commercial environment. Operation of this equipment in a residential area is likely to cause interference, in which case the user at his own expense will be required to take whatever measures may be necessary to correct the interference.

Changes or modifications not expressly approved by the party responsible for compliance could void the user's authority to operate the equipment.

*This digital apparatus does not exceed the Class A limits for radio noise emission from digital apparatus set out in the Radio Interference Regulation of the Canadian Department of Communications.*

*Le présent appareil numérique n'émet pas de bruits radioélectriques dépassant les limites applicables aux appareils numériques de la classe A prescrites dans le Règlement sur le brouillage radioélectrique publié par le ministère des Communications du Canada.*

#### **TRADEMARKS USED IN THIS MANUAL**

AT&T is a registered trademark of American Telephone and Telegraph Company.

Any trademarks mentioned in this manual are acknowledged to be the property of the trademark owners.

**NORMAS OFICIALES MEXICANAS (NOM)  
ELECTRICAL SAFETY STATEMENT****INSTRUCCIONES DE SEGURIDAD**

1. Todas las instrucciones de seguridad y operación deberán ser leídas antes de que el aparato eléctrico sea operado.
2. Las instrucciones de seguridad y operación deberán ser guardadas para referencia futura.
3. Todas las advertencias en el aparato eléctrico y en sus instrucciones de operación deben ser respetadas.
4. Todas las instrucciones de operación y uso deben ser seguidas.
5. El aparato eléctrico no deberá ser usado cerca del agua—por ejemplo, cerca de la tina de baño, lavabo, sótano mojado o cerca de una alberca, etc..
6. El aparato eléctrico debe ser usado únicamente con carritos o pedestales que sean recomendados por el fabricante.
7. El aparato eléctrico debe ser montado a la pared o al techo sólo como sea recomendado por el fabricante.
8. Servicio—El usuario no debe intentar dar servicio al equipo eléctrico más allá a lo descrito en las instrucciones de operación. Todo otro servicio deberá ser referido a personal de servicio calificado.
9. El aparato eléctrico debe ser situado de tal manera que su posición no interfiera su uso. La colocación del aparato eléctrico sobre una cama, sofá, alfombra o superficie similar puede bloquea la ventilación, no se debe colocar en libreros o gabinetes que impidan el flujo de aire por los orificios de ventilación.
10. El equipo eléctrico debe ser situado fuera del alcance de fuentes de calor como radiadores, registros de calor, estufas u otros aparatos (incluyendo amplificadores) que producen calor.

11. El aparato eléctrico deberá ser conectado a una fuente de poder sólo del tipo descrito en el instructivo de operación, o como se indique en el aparato.
12. Precaución debe ser tomada de tal manera que la tierra física y la polarización del equipo no sea eliminada.
13. Los cables de la fuente de poder deben ser guiados de tal manera que no sean pisados ni pellizcados por objetos colocados sobre o contra ellos, poniendo particular atención a los contactos y receptáculos donde salen del aparato.
14. El equipo eléctrico debe ser limpiado únicamente de acuerdo a las recomendaciones del fabricante.
15. En caso de existir, una antena externa deberá ser localizada lejos de las líneas de energía.
16. El cable de corriente deberá ser desconectado del cuando el equipo no sea usado por un largo periodo de tiempo.
17. Cuidado debe ser tomado de tal manera que objetos líquidos no sean derramados sobre la cubierta u orificios de ventilación.
18. Servicio por personal calificado deberá ser provisto cuando:
  - A: El cable de poder o el contacto ha sido dañado; u
  - B: Objetos han caído o líquido ha sido derramado dentro del aparato; o
  - C: El aparato ha sido expuesto a la lluvia; o
  - D: El aparato parece no operar normalmente o muestra un cambio en su desempeño; o
  - E: El aparato ha sido tirado o su cubierta ha sido dañada.

# Contents

1. Specifications.....	5
2. Introduction .....	6
2.1 Overview.....	6
2.2 Features.....	6
3. Configuration .....	7
3.1 Overview.....	7
3.2 Setting the DCE/DTE Switch .....	8
4. Installation.....	9
4.1 Twisted-Pair Wiring.....	9
4.1.1 Twisted-Pair Connection Using Terminal Blocks .....	9
4.1.2 Twisted-Pair Connection Using Modular Jacks .....	14
4.2 Completing the Installation.....	15
Appendix A. RS-232C Pin Configurations.....	16
Appendix B. Block Diagram.....	17

# 1. Specifications

<b>Data Rates</b>	Up to 115.2 Kbps
<b>Connectors</b>	<i>RS-232 side</i> —CL095A-F, CL096A-F, CL097A-F: DB25 female; CL095A-M, CL096A-M, CL097A-M: DB25 male  <i>Current-Loop side</i> —CL095A-F, CL095A-M: Terminal block with strain relief; CL096A-F, CL096A-M: RJ-11; CL097A-F, CL097A-M: RJ-45
<b>Transmission Line</b>	19- to 26-AWG twisted pair
<b>Range</b>	4 miles (6.4 km) on 24-AWG twisted pair
<b>Interfaces</b>	Asynchronous, EIA RS-232, CCITT V.24 full duplex, 20-mA current loop (passive)
<b>Isolation</b>	2500V RMS via opto-isolators
<b>Operating Temperature</b>	32° to 140°F (0° to 60°C)
<b>Humidity</b>	0 to 95%, noncondensing
<b>Altitude</b>	Up to 15,000 feet (4570 m)
<b>Power</b>	No external power required; uses power from RS-232 data signals
<b>Size</b>	1.2"H x ¾"W x 2½"D (3 x 1.9 x 6.4 cm)
<b>Weight</b>	1.5 oz. (42.5 g)

## 2. Introduction

### 2.1 Overview

The HS RS-232↔Current Loop Converter Passive lets an asynchronous RS-232 device communicate with an active 20-mA current-loop device. The HS RS-232↔Current Loop Converter Passive requires no AC power or batteries to operate and supports data rates up to 115.2 Kbps.

Operating at full duplex, the HS RS-232↔Current Loop Converter Passive supports communication distances up to 4 miles (6.4 km) over two unconditioned 24-AWG twisted pairs. To guard against data loss due to ground loops, the HS RS-232↔Current Loop Converter Passive is equipped with 2500V RMS optical isolators on the line side.

The HS RS-232↔Current Loop Converter Passive connects directly to the RS-232 interface using a male or female DB25 connector. Two-pair cable running to the 20-mA current-loop device attaches to the HS RS-232↔Current Loop Converter Passive by RJ-11 jack, RJ-45 jack, or terminal blocks with built-in strain relief. An external DCE/DTE switch on the HS RS-232↔Current Loop Converter Passive eliminates the need for a crossover cable on the RS-232 interface.

### 2.2 Features

- Full-duplex, asynchronous operation over 4 wires.
- Data rates up to 115.2 Kbps.
- No AC power required.
- Optically isolated.
- Twisted-pair connection via terminal blocks, RJ-11, or RJ-45 jacks.
- External DCE/DTE switch.



## 3. Configuration

### 3.1 Overview

The HS RS-232↔Current Loop Converter Passive is easy to use. There are no internal jumpers or DIP switches to set, so there's no need to open the case to configure the unit. (You may need to open the case for wire connection. See **Chapter 4**.) The only configuration necessary for operation is setting the external DCE/DTE switch.

The figure below shows the location of the DCE/DTE switch on the PC board, as well as the location of the terminal block.

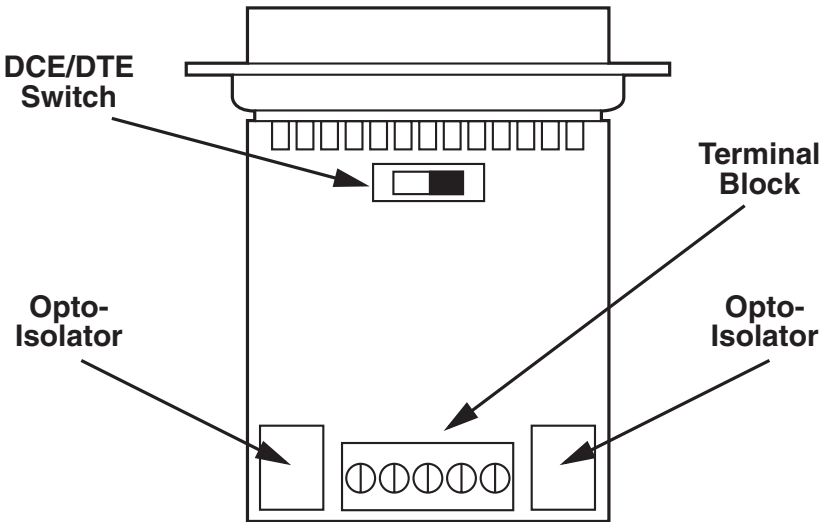

### 3.2 Setting the DCE/DTE Switch

For your convenience, the Converter has an externally accessible DCE/DTE switch (see the diagram below). If the RS-232 device connected to the Converter is a modem or multiplexor (or is wired like one), set the switch to “DTE.” The setting causes the Converter to behave like Data Terminal Equipment and transmit data on pin 2.

If the RS-232 device connected to the Converter is a PC, terminal, or host computer (or is wired like one), set the switch to “DCE.” This setting causes the Converter to behave like Data Communications Equipment and transmit data on pin 3.

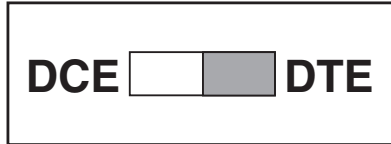

## 4. Installation

The HS RS-232↔Current Loop Converter Passive is simple to install. After configuring the DCE/DTE switch, connect the two twisted pairs using one of three methods: terminal blocks with strain relief, RJ-11 jack, or RJ-45 jack. The method you use will depend on the specific model you have. (See “Connectors” in **Chapter 1** if you aren’t sure which method you should use.)

### 4.1 Twisted-Pair Wiring

Only one HS RS-232↔Current Loop Converter Passive is needed for each RS-232 to 20-mA current-loop circuit. The HS RS-232↔Current Loop Converter Passive is connected to the current-loop device using two twisted pairs. The pairs must be “dry” (unconditioned) metallic wire, 19 to 26 AWG. Best distance is achieved with larger gauges. When you have completed wiring for your data circuit, the pin connections should be as shown below:

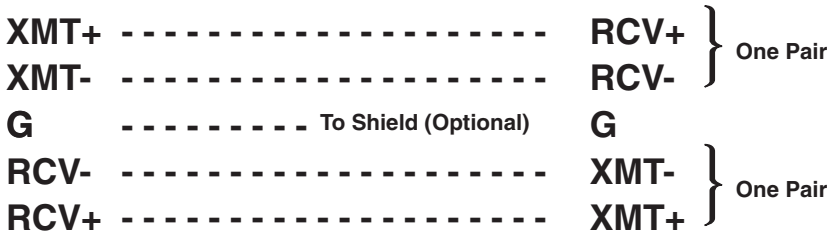

#### 4.1.1 TWISTED-PAIR CONNECTION USING TERMINAL BLOCKS

The terminal block/strain-relief version of the HS RS-232↔Current Loop Converter Passive (CL095A-F and CL095A-M) allows you to hook up the line-side interface using bare wires. The following instructions will tell you how to open the case, connect the bare wires, and fasten the strain-relief collar in place.

## HS RS-232 ↔ CURRENT LOOP CONVERTER PASSIVE

1. Open the unit by gently inserting a screwdriver between the DB25 connector and the lip of the plastic case (see the diagram below). You don't have to worry about breaking the plastic, but be careful not to bend the D-sub connector.

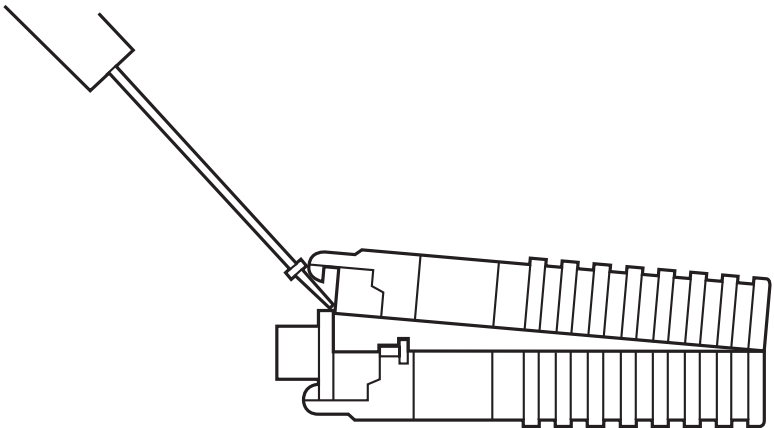
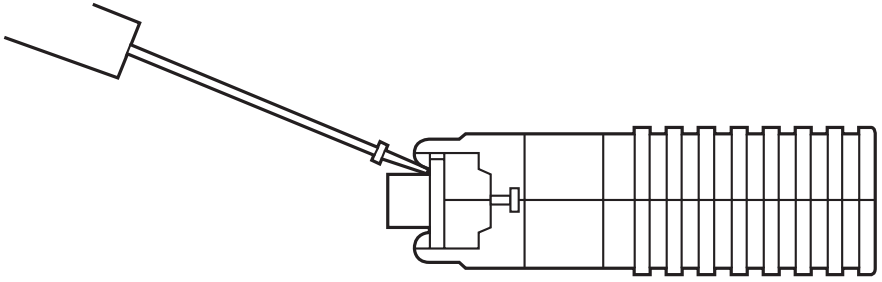

Once the unit has been opened, you will be able to see the terminal blocks located at the rear of the PC board.

2. Strip the outer insulation from the twisted pairs about one inch from the end.

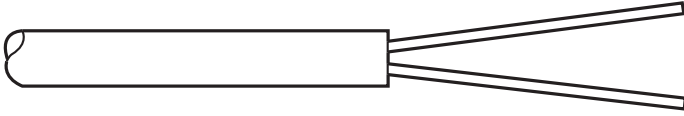

3. Strip back the insulation on each of the two twisted-pair wires about one quarter of an inch.

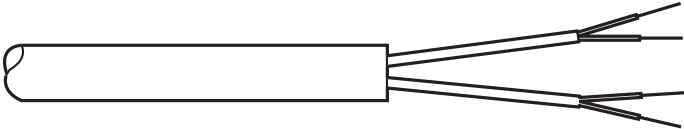

4. Connect *one pair of wires* in the telephone cable to XMT (Transmit) on the terminal block, being careful to observe polarity. (The wire connected to XMT+ must be connected at the other end of the telephone line to RCV+ in the other unit. The wire connected to XMT- must be connected at the other end of the telephone line to RCV- in the other unit.)

5. Connect *the other pair of wires* in the telephone cable to RCV (Receive), again being careful to observe the polarity. (The wire connected to RCV+ must be connected at the other end of the telephone line to XMT+ in the other unit. The wire connected to RCV- must be connected at the other end of the telephone line to XMT- in the other unit.)

6. If there is a shield around the telephone cable, it may be connected to “G” on the terminal block. To avoid ground loops, we recommend connecting the shield at the computer end only. *A ground wire is not necessary for proper operation of these units.*

## HS RS-232 ↔ CURRENT LOOP CONVERTER PASSIVE

7. When you finish connecting the wires to the terminal block, the assembly should resemble the diagram below.

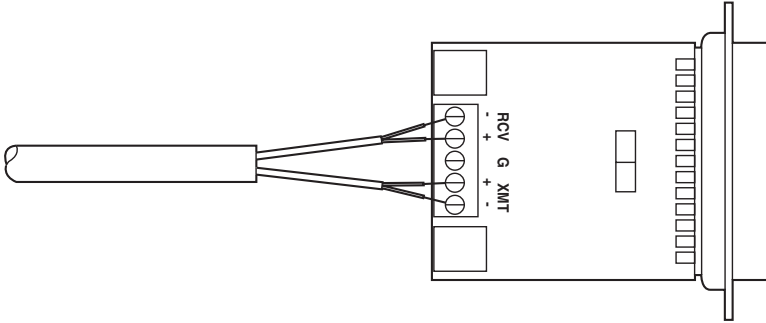

8. Place the two halves of the strain-relief assembly on either side of the telephone wire and press together very lightly. Slide the assembly so that it is about two inches (5.1 cm) from the terminal posts and press together firmly. If your cable diameter is too small or too large for our strain relief, contact your supplier for technical support.

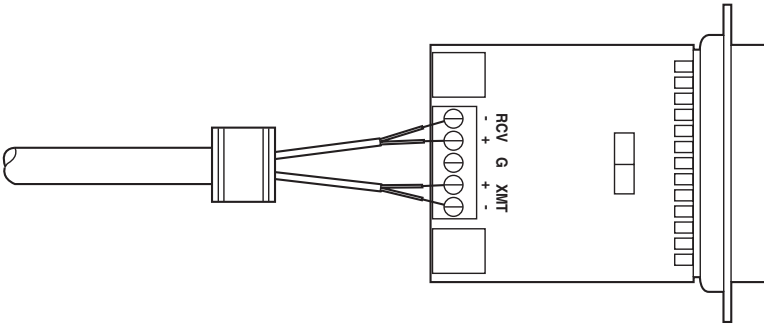

9. Insert the strain-relief assembly with the wire going through it into the slot in the bottom half of the modem case and set it into the recess in the case.

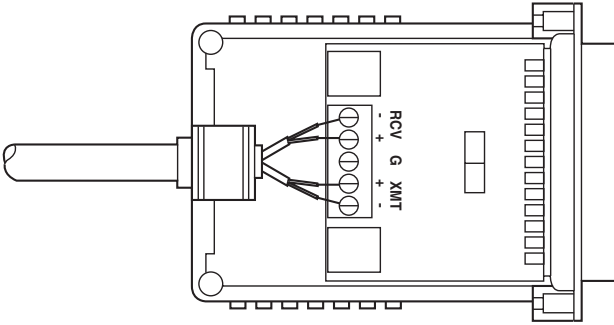

10. Bend the top half of the case as necessary to place it over the strain-relief assembly. Do not snap the case together yet.

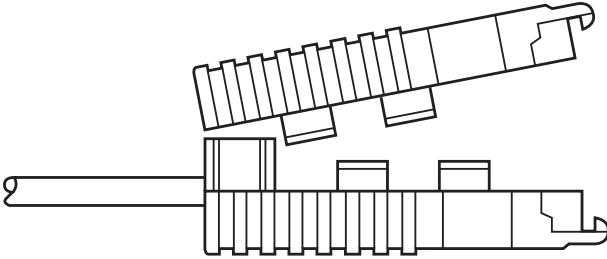

11. Insert one captive screw through a saddle washer, then insert the captive screw with the washer on it through the hole in the DB25 end of the case. Snap that side of the case closed. Repeat the process for the other side. Cable installation is complete.

# HS RS-232↔CURRENT LOOP CONVERTER PASSIVE

## 4.1.2 TWISTED-PAIR CONNECTION USING MODULAR JACKS

The modular versions of the HS RS-232↔Current Loop Converter Passive have an RJ-11 (CL096A-F and CL096A-M) or RJ-45 (CL097A-F and CL097A-M) jack mounted in the case. These jacks are prewired for a standard telco wiring environment. To be sure you have the right wiring, use the table below as a guide.

<u>RJ-11</u>	<u>Signal</u>
1.....	GND <sup>†</sup>
2.....	RCV-
3.....	XMT+
4.....	XMT-
5.....	RCV+
6.....	GND

<u>RJ-45</u>	<u>Signal</u>
1.....	N/C
2.....	GND
3.....	RCV-
4.....	XMT+
5.....	XMT-
6.....	RCV+
7.....	GND
8.....	N/C

<sup>†</sup>Connection to ground is optional

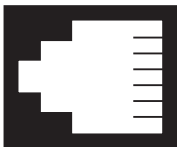

- 1 - Blue
- 2 - Yellow
- 3 - Green
- 4 - Red
- 5 - Black
- 6 - White

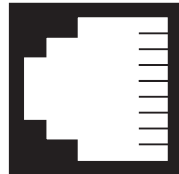

- 1 - Blue
- 2 - Orange
- 3 - Black
- 4 - Red
- 5 - Green
- 6 - Yellow
- 7 - Brown
- 8 - Slate

Figure 1. AT&T® standard color codes.



## **4.2 Completing the Installation**

Once you have configured the Converter for DCE or DTE and connected the twisted-pair wires correctly, simply plug the Converter into the RS-232 data port. Remember to insert and tighten the two captive connector screws.

The HS RS-232↔Current Loop Converter Passive requires no power supply or batteries for operation. It will work automatically at any data rate up to 115.2 Kbps, as long as there is data or control voltage being applied.

# Appendix A. RS-232C Pin Configurations

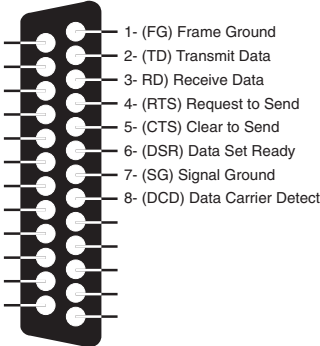
DIRECTION	STANDARD "DCE" SETTING	DIRECTION
To Converter	 <p>1- (FG) Frame Ground 2- (TD) Transmit Data 3- RD) Receive Data 4- (RTS) Request to Send 5- (CTS) Clear to Send 6- (DSR) Data Set Ready 7- (SG) Signal Ground 8- (DCD) Data Carrier Detect</p> <p>Data Term. Ready (DTR) - 20</p>	<p>To Converter From Converter To Converter From Converter From Converter From Converter</p>

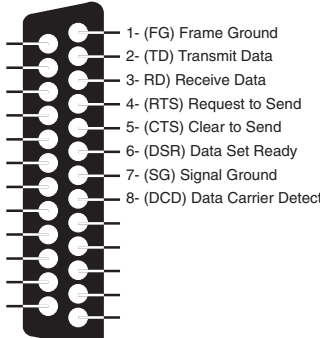
DIRECTION	STANDARD "DTE" SETTING	DIRECTION
From Converter	 <p>1- (FG) Frame Ground 2- (TD) Transmit Data 3- RD) Receive Data 4- (RTS) Request to Send 5- (CTS) Clear to Send 6- (DSR) Data Set Ready 7- (SG) Signal Ground 8- (DCD) Data Carrier Detect</p> <p>Data Term. Ready (DTR) - 20</p>	<p>From Converter To Converter From Converter From Converter To Converter To Converter To Converter</p>

# Appendix B. Block Diagram

