

ServSwitch™ BRAND
CAT5 PS/2
Micro Extender



ACU1007A

Welcome to the ServSwitch™ Family!

Thank you for purchasing a BLACK BOX® ServSwitch™ Brand CAT5 Extender model! We appreciate your business, and we think you'll appreciate the many ways that your enhanced keyboard/video/mouse system will save you money, time, and effort.

That's because our ServSwitch family is all about breaking away from the traditional, expensive model of computer management. You know, the one-size-fits-all-even-if-it-doesn't model that says, "One computer gets one user station, no more, no less." Why not a single user station (monitor, keyboard, and mouse) for multiple computers—even computers of different platforms? Why not a pair of user stations, each of which can control multiple computers? Why not multiple user stations for the same computer?

With our ServSwitch products, there's no reason why not. We carry a broad line of robust solutions for all these applications. Do you have just two PCs, and need an economical alternative to keeping two monitors, keyboards, and mice on your desk? Or do you need to share dozens of computers, including a mix of IBM® PC, RS/6000®, Apple® Macintosh®, Sun Microsystems®, and SGI® compatibles among multiple users with different access levels? Does your switch have to sit solidly on a worktable and use regular everyday cables? Or does it have to be mounted in an equipment rack and use convenient many-to-one cables? No matter how large or small your setup is, no matter how simple or how complex, we're confident we have a ServSwitch system that's just right for you.

The ServSwitch™ family from Black Box—the one-stop answer for all your KVM-switching needs!

*

This manual will tell you all about your new ServSwitch™ Brand CAT5 PS/2 Micro Extender, including how to install, operate, and troubleshoot it. For an introduction to the Extender, see **Chapter 2**. The Extender product code covered in this manual is:

ACU1007A

TRADEMARKS USED IN THIS MANUAL

BLACK BOX and the  logo are registered trademarks, and ServSwitch, Matrix ServSwitch, ServSwitch Affinity, ServSwitch Duo, ServSwitch Multi, ServSwitch Ultra, ServSwitch Wizard, ServSwitch Wizard Pro, ServManager, ServSelect, and ServShare are trademarks, of Black Box Corporation.

Apple and Macintosh are registered trademarks of Apple Computer, Inc.

AT&T is a registered trademark of AT&T.

Pentium is a registered trademark of Intel Corporation.

IBM, PC/AT, PS/2, and RS/6000 are registered trademarks, and PC/XT is a trademark, of International Business Machines Corporation.

Microsoft, IntelliMouse, Windows, Windows Me, Windows NT, and Windows XP are registered trademarks or trademarks of Microsoft Corporation in the United States and/or other countries.

Sun Microsystems is a registered trademark of Sun Microsystems, Inc. in the United States and other countries.

Any other trademarks mentioned in this manual are acknowledged to be the property of the trademark owners.

FEDERAL COMMUNICATIONS COMMISSION AND INDUSTRY CANADA RADIO-FREQUENCY INTERFERENCE STATEMENTS

This equipment generates, uses, and can radiate radio-frequency energy and if not installed and used properly, that is, in strict accordance with the manufacturer's instructions, may cause interference to radio communication. It has been tested and found to comply with the limits for a Class A computing device in accordance with the specifications in Subpart J of Part 15 of FCC rules, which are designed to provide reasonable protection against such interference when the equipment is operated in a commercial environment. Operation of this equipment in a residential area is likely to cause interference, in which case the user at his own expense will be required to take whatever measures may be necessary to correct the interference.

Changes or modifications not expressly approved by the party responsible for compliance could void the user's authority to operate the equipment.

Shielded PC-equipment cables must be used with this equipment to maintain compliance with radio frequency energy emission regulations and ensure a suitably high level of immunity to electromagnetic disturbances.

This digital apparatus does not exceed the Class A limits for radio noise emission from digital apparatus set out in the Radio Interference Regulation of Industry Canada.

Le présent appareil numérique n'émet pas de bruits radioélectriques dépassant les limites applicables aux appareils numériques de la classe A prescrites dans le Règlement sur le brouillage radioélectrique publié par Industrie Canada.

EUROPEAN UNION DECLARATION OF CONFORMITY

WARNING!

This is a class A product. In a domestic environment, this product might cause radio interference, in which case the user might be required to take adequate remedial measures.

This product complies with the following harmonized standards:

- EN55022 (1994), EN55024 (1998)
- EN61000-3-2 (1995), EN61000-3-3 (1995), EN60950 (2000)

When you use this product in environments that have high levels of electromagnetic interference, you might experience some slight disturbance in its operation. If this occurs, please refer to the Troubleshooting chapter of this manual or call technical support.

To maintain compliance, use only cables supplied (or recommended) for use with this product.



NORMAS OFICIALES MEXICANAS (NOM) ELECTRICAL SAFETY STATEMENT

INSTRUCCIONES DE SEGURIDAD

1. Todas las instrucciones de seguridad y operación deberán ser leídas antes de que el aparato eléctrico sea operado.
2. Las instrucciones de seguridad y operación deberán ser guardadas para referencia futura.
3. Todas las advertencias en el aparato eléctrico y en sus instrucciones de operación deben ser respetadas.
4. Todas las instrucciones de operación y uso deben ser seguidas.
5. El aparato eléctrico no deberá ser usado cerca del agua—por ejemplo, cerca de la tina de baño, lavabo, sótano mojado o cerca de una alberca, etc.
6. El aparato eléctrico debe ser usado únicamente con carritos o pedestales que sean recomendados por el fabricante.
7. El aparato eléctrico debe ser montado a la pared o al techo sólo como sea recomendado por el fabricante.
8. Servicio—El usuario no debe intentar dar servicio al equipo eléctrico más allá a lo descrito en las instrucciones de operación. Todo otro servicio deberá ser referido a personal de servicio calificado.
9. El aparato eléctrico debe ser situado de tal manera que su posición no interfiera su uso. La colocación del aparato eléctrico sobre una cama, sofá, alfombra o superficie similar puede bloquea la ventilación, no se debe colocar en libreros o gabinetes que impidan el flujo de aire por los orificios de ventilación.
10. El equipo eléctrico deber ser situado fuera del alcance de fuentes de calor como radiadores, registros de calor, estufas u otros aparatos (incluyendo amplificadores) que producen calor.
11. El aparato eléctrico deberá ser conectado a una fuente de poder sólo del tipo descrito en el instructivo de operación, o como se indique en el aparato.

12. Precaución debe ser tomada de tal manera que la tierra física y la polarización del equipo no sea eliminada.
13. Los cables de la fuente de poder deben ser guiados de tal manera que no sean pisados ni pellizcados por objetos colocados sobre o contra ellos, poniendo particular atención a los contactos y receptáculos donde salen del aparato.
14. El equipo eléctrico debe ser limpiado únicamente de acuerdo a las recomendaciones del fabricante.
15. En caso de existir, una antena externa deberá ser localizada lejos de las líneas de energía.
16. El cable de corriente deberá ser desconectado del cuando el equipo no sea usado por un largo periodo de tiempo.
17. Cuidado debe ser tomado de tal manera que objetos líquidos no sean derramados sobre la cubierta u orificios de ventilación.
18. Servicio por personal calificado deberá ser provisto cuando:
 - A: El cable de poder o el contacto ha sido dañado; u
 - B: Objetos han caído o líquido ha sido derramado dentro del aparato; o
 - C: El aparato ha sido expuesto a la lluvia; o
 - D: El aparato parece no operar normalmente o muestra un cambio en su desempeño; o
 - E: El aparato ha sido tirado o su cubierta ha sido dañada.

Contents

Chapter	Page
1. Quick Start Guide	9
2. Specifications	10
3. Introduction	12
3.1 Compatibility	13
3.2 Key Features	14
4. Checklist of System Components	15
4.1 The Complete Package	15
4.2 The Cables You'll Need	15
4.2.1 To Connect a CPU to the Local Unit	16
4.2.2 To Connect a ServSwitch Family KVM Switch to the Local Unit	16
4.2.3 To Connect a Keyboard and Mouse to the Remote Unit	18
4.2.4 To Connect a ServSwitch Family KVM Switch to the Remote Unit	18
4.2.5 To Connect the Local Unit to the Remote Unit	20
5. Installation	21
5.1 Test-Placing the Extender System (Optional)	21
5.2 Attaching Devices	21
5.2.1 Attaching a CPU to the Local Unit	22
5.2.2 Attaching a ServSwitch Family KVM Switch to the Local Unit	22
5.2.3 Attaching a Keyboard and Mouse to the Remote Unit	24
5.2.4 Attaching a ServSwitch Family KVM Switch to the Remote Unit	24
5.3 Finishing Your Installation	26
6. Operation	27
6.1 Keyboard and Mouse Emulation	27
6.2 Normal Operation and Keyboard Typematic Rate	27

Contents (continued)

Chapter	Page
7. Troubleshooting	28
7.1 Common Problems	28
7.1.1 Keyboard	28
7.1.2 Mouse	29
7.1.3 Both Keyboard and Mouse	30
7.2 General Questions About the Extender	31
7.3 Calling Black Box	32
7.4 Shipping and Packaging	32
Appendix: Cable Pinning/Pairing	33

1. Quick Start Guide

To *install* your ServSwitch™ Brand CAT5 PS/2 Micro Extender system, refer to the illustration below. A basic installation with a CPU, a keyboard, and a mouse is shown.

1. Use the included PS/2 extension cables to attach the CPU to the Local Unit.
2. Plug the remote keyboard and mouse directly into the Remote Unit.
3. Connect the Local and Remote Units with straight-pinned four-pair solid-core CAT5 cable.
4. Power the Remote Unit with its included power supply.

For more information, or if your installation includes any KVM switches, refer to **Chapter 5**.

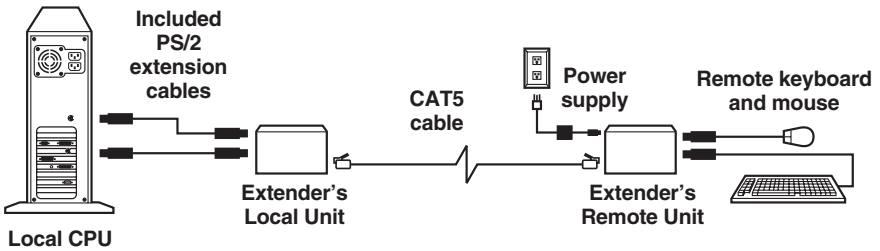

2. Specifications

Cable Required: Between Local and Remote Units: Category 5 solid unshielded or shielded twisted pair (UTP or STP), wired to the EIA/TIA-568A or (preferred) -568B standard, terminated with RJ-45 male connectors; for pinning/pairing, see the **Appendix**

Compliance: CE Class B; FCC Part 15 Subpart J Class A, IC Class/ classe A

Interface: IBM PS/2 compatible

Compatibility: Keyboard: IBM PC/AT or PS/2 compatible (PC/AT types require connector adapter);
Mouse: IBM PS/2 compatible two-button, Microsoft IntelliMouse, or Logitech PS/2 compatible 3-button

Maximum

Distance: 5 m (16 ft.) from the Local Unit to the attached CPU or KVM switch;
5 m (16 ft.) from the Remote Unit to the attached monitor, keyboard, and mouse or KVM switch;
300 m (1000 ft.) between Local and Remote Units

NOTE

With high-quality cables, it might be possible to run farther than 5 m (15 ft.) from the Extender to attached equipment.

Connectors: On Local Unit:
(2) Left-side-mounted 6-pin mini-DIN female for output to CPU's keyboard and mouse ports;
(1) Right-side-mounted RJ-45 female for local/remote interconnection;
On Remote Unit:
(2) Left-side-mounted 6-pin mini-DIN female for input from keyboard and mouse;
Right-side-mounted:
(1) RJ-45 female for local/remote interconnection;
(1) 2.5-mm center-positive barrel jack for power

Temperature

Tolerance: 32 to 104°F (0 to 40°C)

Humidity Tolerance:	5 to 90% noncondensing
Enclosure:	Steel
Power:	Local Unit: 5 VDC at up to 120 mA from CPU's keyboard port; Remote Unit: From desktop power supply (certified to meet the relevant international safety standards): Input: 100 to 240 VAC at 50 to 60 Hz from utility-power (mains) outlet, through detachable power cord and IEC 320 male inlet, to external transformer; Output: 5 VDC regulated, at up to 1 amp, from transformer to Remote Unit
Size:	Each Unit: Height: 1" (2.5 cm); feet protrude an additional 0.1" (0.2 cm) from bottom; Width: 4.3" (10.9 cm); Depth: 3.2" (8.1 cm); additionally, screws protrude less than 0.1" (0.2 cm) from both the front and the back
Weight:	8.3 oz. (235 g)

3. Introduction

By using the Local and Remote Units that together make up the ServSwitch™ Brand CAT5 PS/2 Micro Extender, you can place your keyboard and mouse as far as 300 meters (1000 ft.) from a PC's CPU. The Local and Remote Units are interconnected with a single industry-standard Category 5 UTP or STP 4-pair cable. All keyboard and mouse signals are fully buffered to ensure consistent remote operation of your PC.

The Extender operates automatically and works with all operating systems—no software is required. Just connect the Units as described in **Chapter 5** and you're ready to work!

Because the Extender performs complete PS/2® keyboard and mouse emulation, you can boot the PC without having a keyboard or mouse attached to it. Your PC will boot even if the Extender's Remote Unit is not powered or has no keyboard or mouse connected to it.

3.1 Compatibility

The ServSwitch Brand CAT5 PS/2 Micro Extender is designed to operate in various environments and with a mix of hardware from different manufacturers. During development, this product was extensively tested with a wide variety of hardware. However, please note that it is impossible for us to guarantee that the Extender will interoperate correctly with every keyboard, mouse, and motherboard variant currently on the market. If you suspect that you're having incompatibility problems, please call Black Box Technical Support.

In general, the Extender is compatible with the following types of equipment:

- **CPU:** IBM® PC/AT®, PS/2, and 100% compatible clones. These should be desktop machines; laptops and docking stations are not supported.
- **Keyboard:** Standard (101- or 102-key) PS/2 type or enhanced PS/2 type (104- or 105-key, designed for use with versions of Windows® starting with Windows 95). Although we don't recommend this, you might also be able to use a PC/AT type keyboard with 5-pin DIN connectors; you'll need adapters to attach it and its native CPU to the Extender (see the start of **Section 4.2**). Some older PC/XT™ or PC/AT type autosensing keyboards might not be compatible with the Extender. If the keyboard you want to use is some other type or has some other type of connector, call Black Box for technical support.
For information about keyboard typematic support, see **Section 6.2**.
- **Mouse:** Standard PS/2 type, Microsoft® IntelliMouse® compatible, or Logitech™ 3-button PS/2 compatible mouse; the CPU should have standard PS/2 type mouse ports. If your PC doesn't have a PS/2 style mouse port, you'll need a special adapter to attach the PS/2 mouse cable to one of the PC's serial ports (see the start of **Section 4.2**). The Extender is *not* compatible with serial mice or bus mice. If a mouse you want to attach is some other type or has some other type of connector, call Black Box Technical Support.

3.2 Key Features

The ServSwitch Brand CAT5 PS/2 Micro Extender has a number of useful features which contribute to the transparent remote operation of your PC. Some of the more important ones are:

- **Distance up to 300 m (1000 ft.)**
Operate your PC from the next room or all the way down the hall.
- **Fully buffered signals**
Remote operation of the PC is consistently smooth and transparent.
- **Intelligent PS/2 keyboard and mouse emulation**
With this, the PC boots and operates correctly under most circumstances, and you can freely detach and reconnect the keyboard and mouse as necessary (the Extender automatically initializes the keyboard and mouse as soon as it detects that you've reattached them).
- **Microsoft IntelliMouse compatibility**
Use this and compatible "wheel mice" with confidence.

We recommend that you read the remainder of this manual before you install the Extender in order to fully familiarize yourself with the system.

4. Checklist of System Components

4.1 The Complete Package

These items should be included with your ServSwitch™ Brand CAT5 PS/2 Micro Extender package (please contact Black Box right away if any are missing or damaged):

- (1) Extender Local Unit.
- (1) Extender Remote Unit.
- (1) 5-VDC 1-amp power-supply transformer and output cord.
- (1) Power-supply input cord suitable for your country or region.
- (2) 6-ft. (1.8-m) PS/2 extension cables with 6-pin mini-DIN connectors to connect your PC CPU to the Extender. (If your PC has 5-pin DIN keyboard connectors, see the start of **Section 4.2** for how you'll connect it.)
- (1) Copy of this manual.

4.2 The Cables You'll Need

If you are using the ServSwitch™ Brand CAT5 PS/2 Micro Extender to get greater distance between a CPU and a PS/2 keyboard and mouse, your Extender package should have included everything you'll need except for your Unit-interconnection cable. Read **Sections 4.2.1, 4.2.3, and 4.2.5** carefully, then skip ahead to **Chapter 5**.

If you are using the Extender to get greater distance between a ServSwitch family KVM switch and a CPU or a keyboard/mouse user station, you might need additional non-included cabling. Read the relevant sections on the next few pages, from **Section 4.2.1** through **Section 4.2.5**.

If you are using any equipment with PC/AT style connectors, you might also need some combination of these adapters:

- To attach a CPU or KVM switch with a 5-pin DIN female keyboard connector to the Local Unit: A keyboard-port adapter such as product code FA211.
- To attach a CPU or KVM switch with an RS-232 serial DB9 male mouse connector to the Local Unit: A mouse-port adapter such as product code AC244A. (If the mouse port is DB25 rather than DB9, you'll also need an FA521A serial adapter.)
- To attach a keyboard or KVM switch with a 5-pin DIN male keyboard connector to the Local or Remote Unit: A keyboard adapter such as product code FA212.

4.2.1 TO CONNECT A CPU TO THE LOCAL UNIT

You'll use the PS/2 extension cables included with the ServSwitch™ Brand CAT5 PS/2 Micro Extender to make this connection.

4.2.2 TO CONNECT A SERVSWITCH FAMILY KVM SWITCH TO THE LOCAL UNIT

You would do this to extend the distance you can run from the KVM switch to a keyboard and mouse.

The Local Unit has 6-pin mini-DIN keyboard and mouse connectors mounted on the opposite end of the Unit from the RJ-45 jack. Which cable(s) you'll use to attach the KVM switch to these connectors will depend on what type of user ports the switch model has, as detailed in the following three subsections.

4.2.2.A Switches Whose User Ports Are a Set of Separate Interfaces

The user ports of some ServSwitch family KVM switches are a set of separate interfaces: Each user port consists of separate interfaces/connectors for video, keyboard, and mouse communication. At the time of this writing, some of the important ServSwitch family models in this category are:

- ServSwitch™ Duo
- ServSwitch™ Wizard, Wizard LP, Wizard Pro
- ServSwitch™ Jr.
- Personal ServSwitch™
- ServSelect™
- ServSwitch™ Multi Base Unit or MX (“local console” user port only)

To attach a user port on one of these switches to the Local Unit's CPU port, you can use the PS/2 extension cables included with the Extender.

4.2.2.B Switches with DB25 Composite User Ports

The user ports of several ServSwitch family KVM switches are specially pinned DB25 connectors that function as composite (all-in-one) interfaces. At the time of this writing, some of the important ServSwitch family models in this category are:

- ServSwitch™
- ServSwitch™ Ultra
- Matrix ServSwitch™
- ServSwitch™ Affinity
- ServShare™

To attach a user port on one of these switches to the Local Unit's keyboard and mouse connectors, you'll need a three-to-one ServSwitch User Cable (product code EHN054B for standard or EHN283 for coaxial), *plus* the PS/2 extension cables included with the Extender. Refer to **Section 5.2.2.B** for a description of how this cabling fits together.

4.2.2.C ServSwitch Multi (HD62 Composite User Ports)

The user ports on User Cards installed in the ServSwitch Multi are HD62 female connectors that function as composite (all-in-one) interfaces. To attach one of these ports to the Local Unit's CPU port, you'll need a many-to-one ServSwitch Multi User Cable such as product code KV2505, *plus* the PS/2 extension cables included with the Extender. Refer to **Section 5.2.2.B** for a description of how this cabling fits together.

4.2.3 TO CONNECT A KEYBOARD AND MOUSE TO THE REMOTE UNIT

You'll be plugging the keyboard and mouse directly into the corresponding connectors on the Remote Unit.

4.2.4 TO CONNECT A SERVSWITCH FAMILY KVM SWITCH TO THE REMOTE UNIT

You would do this to extend the distance you can run from the KVM switch to a CPU.

On the Remote Unit and the Dual-Access Local Unit, the user ports are the HD15 and 6-pin mini-DIN connectors on the opposite end of the Unit from the RJ-45 jack. Which cable(s) you'll use to connect the switch to it will depend on what type of CPU ports the switch model has, as detailed in the following three subsections.

4.2.4.A Switches Whose CPU Ports Are a Set of Separate Interfaces

The CPU ports of some ServSwitch family KVM switches are a set of separate interfaces: Each CPU port consists of separate interfaces/connectors for video, keyboard, and mouse communication. At the time of this writing, some of the important ServSwitch family models in this category are:

- ServSwitch™ Duo
- ServSwitch™ Wizard, Wizard LP, Wizard Pro
- Personal ServSwitch™

You can use the PS/2 extension cables included with the Extender to attach a CPU port on one of these switches to the keyboard and mouse connectors on the Remote Unit. If you'll need those cables to attach a CPU or KVM switch to the Local Unit, buy two more separately (product code EVMPS03-MM).

4.2.4.B Switches with Regular ServSwitch Style DB25 Composite CPU Ports

The CPU ports of the regular ServSwitch and several other ServSwitch family KVM switches are specially pinned DB25 connectors that function as composite (all-in-one) interfaces. At the time of this writing, some of the other important ServSwitch family models in this category are:

- ServSwitch Ultra
- Matrix ServSwitch
- ServSwitch Affinity
- ServSwitch Jr.
- ServShare

(Note: The ServSelect also has DB25 composite CPU ports, but they are pinned differently. See **Section 4.2.4.C.**)

To attach a CPU port on one of these switches to the keyboard and mouse connectors on a Remote Unit, you'll need a ServSwitch CPU Cable (product code EHN051B for standard or EHN282 for coaxial).

4.2.4.C Switches with Other Types of Composite CPU Ports

The CPU ports of some ServSwitch family KVM switches are composite (all-in-one) interfaces that are not the same as those on the regular ServSwitch, but the principle for connecting them is the same:

- The CPU ports on CPU Cards installed in the ServSwitch Multi are HD44 female connectors. To attach one of these CPU ports to the keyboard and mouse connectors on a Remote Unit, you'll need a ServSwitch Multi CPU Cable such as product code KV2020-R2.
- The CPU ports on the ServSelect are DB25 connectors pinned *differently from* the DB25 connectors on the regular ServSwitch. To attach one of these CPU ports to the keyboard and mouse connectors on a Remote Unit, you'll need a ServSelect Cable (product code EHN056).

4.2.5 TO CONNECT THE LOCAL UNIT TO THE REMOTE UNIT

To interconnect the Local and Remote Units of the Extender, you'll need industry-standard structured cabling (Category 5 UTP or STP, 4-pair) terminated with RJ-45 plugs. This cable is not included with the Extender. Order CAT5 patch cables such as our product code EYN737MS or CAT5 bulk cable such as our EYN840A. The bulk cable should be terminated with high-quality RJ-45 plugs such as those included in our FM732 25-pack.

CAUTION!

The pairing of this cable and pinning of its connectors must be in accordance with EIA/TIA-568A or (preferably) EIA/TIA-568B. (Refer to the wiring chart in the Appendix. Please note that failure to wire the twisted pairs correctly might prevent correct operation.)

Even though your network might use the same type of 4-wire twisted-pair cabling, do *not* connect the Extender to 10BASE-T Ethernet devices or any other network equipment. Doing so will virtually destroy the Extender's circuitry and could also damage the attached equipment.

The Extender is designed for use up to a maximum cable length of 300 m (1000 ft.). Although a single continuous length of interconnect cable is preferable, it's possible to operate a Extender system if the Local and Remote Units are connected through multiple patch panels.

Unlike other ServSwitch™ brand extenders that carry video signals, the CAT5 PS/2 Micro Extenders can tolerate the tighter twist ratios of twisted-pair cables rated higher than Category 5. They can also tolerate stranded-core as well as solid-core cable.

NOTE

The Extender has been tested and found to work, *in certain situations*, with 4-pair Category 3 cable or with four pairs of 25-pair UTP trunk cables instead of 4-pair Category 5 cable. We do not recommend such installations; if you want to experiment with them, do so at your own risk.

5. Installation

To install your ServSwitch™ Brand CAT5 PS/2 Micro Extender system, first test-place it (if you want to) as described in **Section 5.1**, then attach devices as described in **Section 5.2**, then finish your installation as described in **Section 5.3**.

5.1 Test-Placing the Extender System (Optional)

We recommend testing your Extender system with a test setup confined to a single room; that way, if any components are bad, you can find out before you run cable halfway across your campus. If you want to do this, gather your equipment in your test site; otherwise, place the Extender's Local and Remote Units, and the equipment you'll be attaching to them, in your desired locations.

5.2 Attaching Devices

For instructions on making device connections, refer to these subsections:

- **Section 5.2.1** for attaching a CPU to the Local Unit.
- **Section 5.2.2** for attaching a KVM switch to the Local Unit.
- **Section 5.2.3** for attaching a keyboard and mouse to the Remote Unit.
- **Section 5.2.4** for attaching a KVM switch to the Remote Unit.

As you attach devices to the Extender, here are some things to keep in mind:

- The keyboard connectors on the Extender Units are labeled with a keyboard icon and the mouse connectors are labeled with a mouse icon. Make sure you don't attach your keyboard and mouse, or your keyboard- and mouse-extension cables, backwards.
- Each powered device should be powered OFF when you attach it.

5.2.1 ATTACHING A CPU TO THE LOCAL UNIT

Run the included PS/2 extension cables from the CPU to the Local Unit: keyboard port to keyboard connector, mouse port to mouse connector.

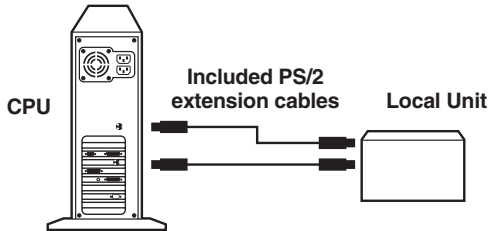

Figure 5-1. Attaching a CPU to the Local Unit.

5.2.2 ATTACHING A SERVSWITCH FAMILY KVM SWITCH TO THE LOCAL UNIT

The way you'll do this will depend on what kind of user ports the KVM switch has: multiple connectors (see **Section 5.2.2.A**) or single composite connectors (see **Section 5.2.2.B**). (Refer to the listings in **Section 4.2.2** for which ServSwitch family models are in which category.)

5.2.2.A Attaching a Switch with Multiple User-Port Connectors

Run the included PS/2 extension cables from one of the KVM switch's user ports to the Local Unit: keyboard connector to keyboard connector, mouse connector to mouse connector.

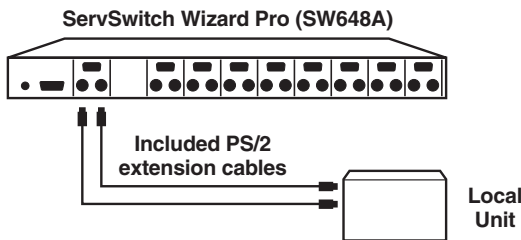

Figure 5-2. Attaching a KVM switch with multiple user-port connectors to the Local Unit.

5.2.2.B Attaching a Switch with a Single Composite User-Port Connector

First plug the included PS/2 extension cables into the Local Unit's keyboard and mouse connectors. Then plug a User Cable designed for the KVM switch—refer to **Sections 4.2.2.B** and **4.2.2.C** for product codes—into one of the switch's user ports. Connect the matching ends of the extension cables and User Cable together as shown in Figure 5-3. The User Cable's video strand won't be used.

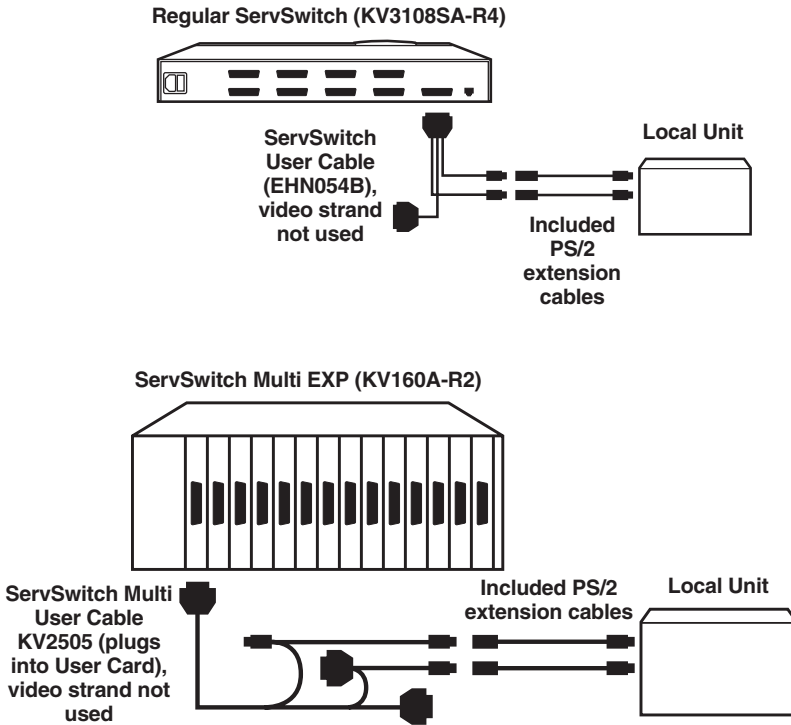

Figure 5-3. Attaching a KVM switch with a single user-port connector, such as a regular ServSwitch (top) or ServSwitch Multi (bottom), to the Local Unit.

5.2.3 ATTACHING A KEYBOARD AND MOUSE TO THE REMOTE UNIT

Plug the keyboard and mouse directly into the Remote Unit's matching connectors.

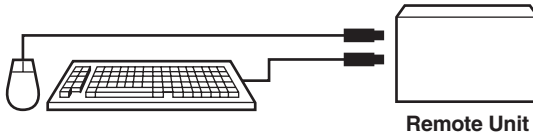

Figure 5-4. Attaching a keyboard and mouse to the Remote Unit.

5.2.4 ATTACHING A SERVSWITCH FAMILY KVM SWITCH TO THE REMOTE UNIT

The way you'll do this will depend on whether the switch's CPU ports are multiple connectors (see **Section 5.2.4.A**) or single connectors (see **Section 5.2.4.B**). (Refer to the listings in **Section 4.2.4** for which switch models are in which category.)

5.2.4.A Attaching a Switch with Multiple CPU-Port Connectors

Run the included PS/2 extension cables (or equivalent cables—see **Section 4.2.4.A**) from one of the KVM switch's CPU ports to the Remote Unit: keyboard connector to keyboard connector, mouse connector to mouse connector.

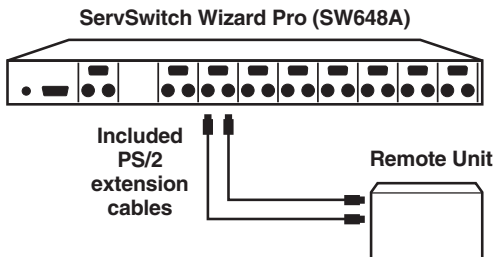

Figure 5-5. Attaching a KVM switch with multiple CPU-port connectors to the Remote Unit.

5.2.4.B Attaching a Switch with Single Composite CPU-Port Connectors

Run a CPU Cable designed for the KVM switch—refer to **Sections 4.2.4.B** and **4.2.4.C** for product codes—from one of the switch's CPU ports to the Remote Unit's keyboard and mouse connectors. The cable's video strand won't be used.

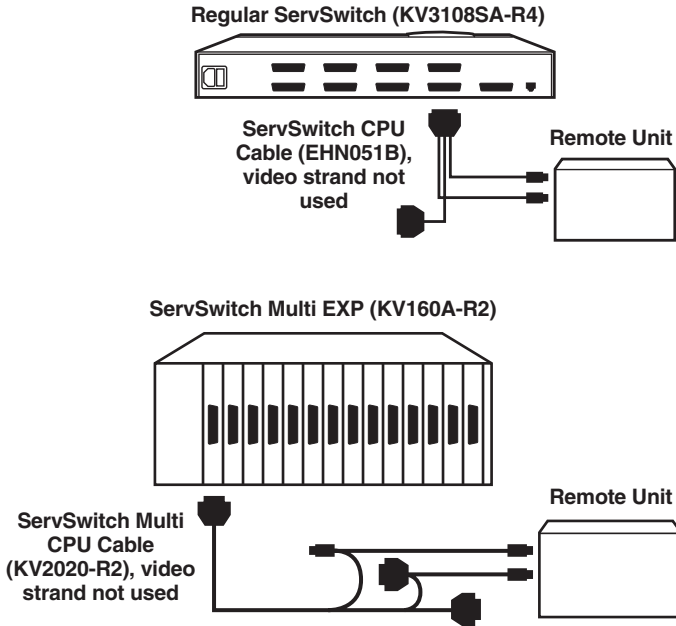

Figure 5-6. Attaching a KVM switch with a single CPU-port connector, such as a regular ServSwitch (top) or ServSwitch Multi (bottom), to the Remote Unit.

5.3 Finishing Your Installation

To finish installing your Extender system after attaching devices to it as described in **Section 5.2**, take these steps:

1. Attach the output cord of the Remote Unit's power supply to the Unit's power jack. Then plug the IEC 320 end of the power supply's input cord into the IEC 320 inlet on the power supply's transformer. Finally, plug the other end of the input cord into a utility (mains) power outlet. The Remote Unit should power up immediately; it has no ON/OFF switch. (If the Remote Unit is in the location you want it to be, you can leave it plugged in and powered up more or less indefinitely.)
2. If you have a KVM switch attached to the Remote Unit, power it ON.
3. Interconnect the Local and Remote Units by running CAT5 cable between their right-side-mounted modular jacks (the ones labeled "Interconnect"). Refer to the guidelines for this cable in **Section 4.2.5**.
4. Power ON the PC CPU or KVM switch attached to the Local Unit's CPU port. If the CPU or switch provides enough DC voltage on its keyboard port/leads, the Local Unit will begin operating immediately; like the Remote Unit, it has no ON/OFF switch.
5. Make sure that the remote keyboard and mouse both function properly. (If your PC normally boots up in DOS, you will need to run Windows or some application that supports the mouse.)

If everything works in your test setup, repeat the above steps for your actual installation. If everything works in the actual installation, your ServSwitch™ Brand CAT5 PS/2 Micro Extender system should be ready for continuous operation.

6. Operation

6.1 Keyboard and Mouse Emulation

The ServSwitch™ Brand CAT5 PS/2 Micro Extender uses a microprocessor to emulate the presence of a directly connected keyboard and mouse for the attached PC. This means that you don't have to connect a keyboard or mouse to the PC in order for it to boot; in fact, the PC will boot with only the Local Unit connected.

This feature makes several other things possible:

- Your PC can operate continuously regardless of whether or not the Extender's Remote Unit is powered, connected, or even present.
- You can “hot-plug” or “hot-swap” keyboards and mice attached to the Extender at any time; that is, you can unplug and replug the keyboard and mouse without disrupting the operation of the PC.
- You can connect the Local Unit of one Extender system to the Remote Unit of a different Extender system—effectively creating a keyboard-and-mouse-switching matrix—by swapping the systems' interconnection cables. (We do not recommend that you do this; if you feel that you need to, please call Black Box for technical support first.)

6.2 Normal Operation and Keyboard Typematic Rate

The ServSwitch™ Brand CAT5 PS/2 Micro Extender should operate continuously and transparently, maintaining the long-distance connection between the local CPU or switch and the remote switch or keyboard/mouse user station. Note that the remote keyboard's typematic rate—the rate at which a held-down character will repeat—is fixed at 30 characters per second, which is also the default typematic value for Windows.

7. Troubleshooting

7.1 Common Problems

This section discusses difficulties that people sometimes have with the ServSwitch™ Brand CAT5 PS/2 Micro Extender, and suggests possible remedies. If the recommended actions don't help, try rebooting the PC. If all else fails, or if you don't see your problem here, or if your problem keeps recurring, call Black Box Technical Support as directed in **Section 7.3**.

7.1.1 KEYBOARD

The PC boots correctly with no error messages but the keyboard does not work at all.

1. Check the keyboard cable and (if necessary) the PS/2 keyboard-extension cable going to the CPU; if either of them are loose, or if you have the keyboard and mouse cables reversed (plugged into each other's Extender ports), plug the cable(s) in properly and cycle power to the Remote Unit.
2. Check the interconnect cable between the Extender's Local and Remote Units. Is it intact along its length and securely connected at both ends? And is it wired correctly? (Compare its wiring with that shown in the **Appendix**.)
3. If the PC is a Pentium® class machine, see the entry for the "My Pentium class PC..." problem in **Section 7.1.3**.
4. Try a different model of keyboard. If the new keyboard works, the original one might be incompatible (some older autosensing keyboards don't work with the Extender).

When I press keys on my keyboard the wrong characters appear.

Cycle power to the Remote Unit. If this doesn't work, reboot the PC.

The PC always comes up with "Keyboard Error."

1. If the system appears to work fine after you press [F1] or [ESC], adjust your BIOS setup so that the PC doesn't test the keyboard.
2. If the PC is a Pentium class machine, see the entry for the "My Pentium class PC..." problem in **Section 7.1.3**.

7.1.2 MOUSE

The CPU's video shows a mouse cursor/pointer, but the mouse does not work.

1. Cycle power to the Remote Unit.
2. Check the mouse cable and (if necessary) the PS/2 mouse-extension cable; if it's loose, or if you have the keyboard and mouse cables reversed (plugged into each other's Extender ports), plug the cable(s) in properly and cycle power to the Remote Unit.
3. If the PC is a Pentium class machine, see the entry for the "My Pentium class PC..." problem in **Section 7.1.3**.
4. Check the interconnect cable between the Extender's Local and Remote Units. Is it intact along its length and securely connected at both ends? And is it wired correctly? (Compare its wiring with that shown in the **Appendix**.)
5. Try using a different model of mouse.

The PC does not detect a PS/2 mouse, or the application cannot find the mouse.

1. Check the mouse cable; if it's loose, or if you have the keyboard and mouse cables reversed (plugged into each other's Extender ports), plug the cable(s) in properly and cycle power to the Remote Unit.
2. Make sure that the cable running from the keyboard port of the CPU or KVM switch to the Extender's Local Unit is intact and securely attached, so that it provides power to the Local Unit.
3. If the PC is a Pentium class machine, see the entry for the "My Pentium class PC..." problem in **Section 7.1.3**.

The mouse is behaving erratically.

1. If your PC is running Windows 95/98/2000, Windows Me®, Windows NT®, or Windows XP®, regardless of what type of mouse you have, install the latest Microsoft driver for a standard mouse or (even if you have a standard mouse) the IntelliMouse. The Extender will translate the mouse signals for this driver, and the driver will auto-correct the synching problem if you let go of the mouse for a second or two.
2. If you're using the Extender in conjunction with one of our ServSwitch family of KVM switches, command the switch to reset the mouse.
3. Quit and restart the application.

7.1.3 BOTH KEYBOARD AND MOUSE

Neither the keyboard nor the mouse operates, or both have locked up.

1. Reset the PC and try again.
2. If the problem is happening at a remote station, cycle power to the Remote Unit.

My Pentium class PC will not boot properly due to keyboard or mouse problems, or After my Pentium class PC boots, the keyboard and/or mouse won't work.

Try “crossing” the keyboard- and mouse-extension cables running from the Extender to your PC. That is, plug the keyboard cable into the mouse port and the mouse cable into the keyboard port.

If this works, here's why: The BIOS installed in some PCs with Pentium family processors, especially those with clock speeds of 300 MHz and up, checks the PC's keyboard and mouse ports at boot time. If it detects anything that leads it to suspect that the user has plugged the keyboard and mouse in backwards—that is, into each other's CPU ports—it “remaps” the ports, so that the keyboard port functions as the mouse port and vice versa. BIOS of this type sometimes mistakenly activates port remapping when the PC is attached to an Extender.

7.2 General Questions About the Extender

Is it possible to use an interconnection cable longer than 300 meters (1000 feet)?

Can Extenders be daisy-chained to operate across greater distances?

We don't recommend doing either of these things.

Can the Extender be used between buildings?

No. Ground loops could destroy the Extender and attached equipment.

Can I rackmount the Extender?

The Extender is designed for desktop use. You could set it on a rack shelf, but there are not currently any rackmount or wallmount kits available for it.

Which cable type is better: UTP (unshielded twisted-pair) or STP (shielded twisted pair)?

In electrically quiet environments, UTP cable will give the best quality video over long distances because it has less capacitance per unit length. However, STP is usually better in electrically noisy environments, because it resists interference more strongly.

When using UTP, what's the best way to make sure that the system does not suffer from any interference?

The Extender is designed to withstand high levels of interference while driving signals over UTP. To further reduce the potential for interference, consider taking these actions:

- a) Make sure that the Extender's Remote Unit, any remote KVM switch, and the local CPU or KVM switch are all connected to the same utility-power (mains) phase.
- b) Make sure that the AC voltage across the utility-power (mains) grounds (at both the local PC or switch and remote monitor or switch) is less than 2V.
- c) Use a "clean earth" or "clean grounding" system (if your site has one installed).
- d) Route the interconnection cable away from generators, motors, compressors, fluorescent lights, and other cables.
- e) Try STP cable if you think noise could be a problem.

This interconnect cable is exactly like the cable I use on my LAN. Can I connect the Extender to my network?

Absolutely not. Regardless of the cable similarities, the data signals and voltages used by the Extender are totally different from those used by Ethernet and other types of networks. Connecting the Extender to a LAN hub, switch, repeater, or other network device, or exposing it to the signal levels present on network data lines, is a sure way to blow out the Extender, and could damage attached devices as well.

7.3 Calling Black Box

If you determine that your ServSwitch™ Brand CAT5 PS/2 Micro Extender is malfunctioning, *do not attempt to alter or repair it*. It contains no user-serviceable parts. Contact Black Box Technical Support at 724-746-5500.

Before you do, make a record of the history of the problem. We will be able to provide more efficient and accurate assistance if you have a complete description, including:

- the firmware-revision level printed on the bottom of the Extender's Local and Remote Units (very important, especially for keyboard and mouse problems);
- the nature and duration of the problem;
- when the problem occurs;
- the components involved in the problem—that is, what type of computers, what type of keyboard, brand of mouse, type and make of CAT5 cable, etc.;
- any particular application that, when used, appears to create the problem or make it worse; and
- the results of any testing you've already done.

To solve some problems, it might be necessary to upgrade the Extender's firmware. If this turns out to be the case for your difficulty, our technical support technicians will arrange for you to receive the new firmware and will tell you how to install it.

7.4 Shipping and Packaging

If you need to transport or ship your ServSwitch™ Brand CAT5 PS/2 Micro Extender:

- Package it carefully. We recommend that you use the original container.
- If you are shipping the unit for repair, please include its PS/2 extension cables and all parts of its external power supply. If you are returning the unit, please include everything you received with it. Before you ship it back to Black Box for repair or return, contact us to get a Return Authorization (RA) number.

Appendix: Cable Pinning/Pairing

The cable you will use to interconnect the Local and Remote Units of your ServSwitch™ Brand CAT5 PS/2 Micro Extender should be terminated with RJ-45 plugs and should be wired according to the EIA/TIA-568 standard (preferably 568B rather than 568A). See **Section 4.2.5** for a more complete set of cable recommendations.

Looking into the interconnect socket on either Extender Unit, or looking at the cable plug from behind, Pin 1 should be on the left and Pin 8 on the right, and the wires should be arranged this way:

Pin	Color	Function, Pair
1	White/Orange	TX, Pair 2
2	Orange/White	RX, Pair 2
3	White/Green	TX, Pair 3
4	Blue/White	RX, Pair 1
5	White/Blue	TX, Pair 1
6	Green/White	RX, Pair 3
7	White/Brown	TX, Pair 4
8	Brown/White	RX, Pair 4

NOTES

The Extender has been tested with all major makes of CAT5 cable including Black Box, Berk-Tek™, Mohawk®, and AT&T®. The Extender has also been tested and found to work, *in certain situations*, with 4-pair Category 3 cable or with four pairs of 25-pair UTP trunk cables instead of 4-pair Category 5 cable. But we do *not* recommend such installations; if you want to experiment with them, do so at your own risk.

DISCLAIMERS

While every precaution has been taken in the preparation of this manual, the manufacturer assumes no responsibility for errors or omissions. Neither does the manufacturer assume any liability for damages resulting from the use of the information contained herein. They reserve the right to change the specifications, functions, or circuitry of the product without notice.

The manufacturer cannot accept liability for damage due to misuse of the product or due to other circumstances outside the manufacturer's control. And the manufacturer will not be responsible for any loss, damage, or injury arising directly or indirectly from the use of this product.

NOTES

NOTES



REGULAR-1M5

Customer Support Information:

FREE tech support 24 hours a day, 7 days a week: Call **724-746-5500** or fax **724-746-0746**.

Mailing address: **Black Box Corporation**, 1000 Park Dr., Lawrence, PA 15055-1018

World-Wide Web: www.blackbox.com • E-mail: info@blackbox.com

© Copyright 2002. Black Box Corporation. All rights reserved.