

# BLACK BOX<sup>®</sup> ServSwitch<sup>™</sup>

*Wizard skew  
Compensator*

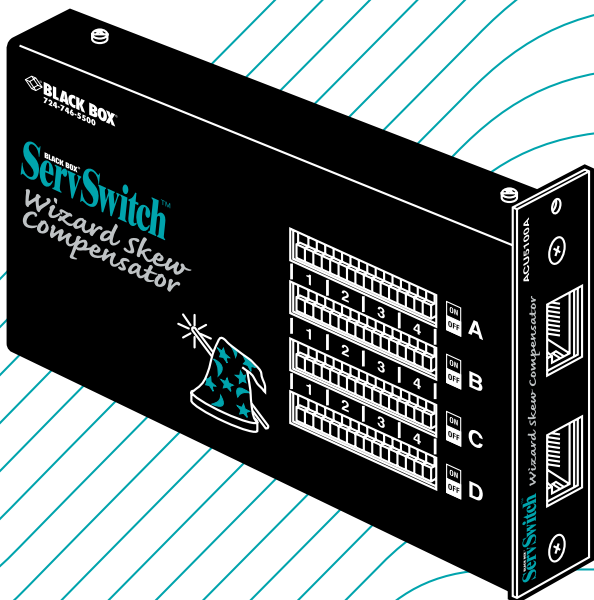

ACU5100A

# Welcome to the ServSwitch™ Family!

Thank you for purchasing BLACK BOX® ServSwitch™ Brand video equipment! We appreciate your business, and we think you'll appreciate the many ways that this product will save you money, time, and effort.

Our ServSwitch family is all about breaking away from the traditional, expensive model of computer management and display. You know, the one-size-fits-all-even-if-it-doesn't model that says, "One computer gets one dedicated monitor or user station, no more, no less." Why not a single user station (monitor, keyboard, and mouse) for multiple computers—even computers of different platforms? Why not a pair of user stations, each of which can control multiple computers? Why not many monitors or user stations for the same computer? Why not access or display any of your computers, anywhere in the world, with any of your user stations or monitors?

With our ServSwitch products, there's no reason why not. We carry a broad line of robust solutions for all these applications:

- Do you have just two PCs and need an economical alternative to keeping two mice, keyboards, and monitors on your desk? Or do you need to share many computers, including a mix of IBM® PC, RS/6000®, Apple® Macintosh®, Sun Microsystems®, and SGI™ types among multiple worldwide users with different access levels?
- Do you have to send video from one computer to two different local monitors? Or do you need to send video from multiple computers to dozens of remote monitors?
- Does your switch have to sit solidly on a worktable and use regular everyday cables? Or does it have to be mounted in an equipment rack, use convenient many-to-one cables, and have a rackmounted user station that folds and slides into 1U of space?

No matter how large or small your setup is, no matter how simple or how complex, we're confident we have a ServSwitch system that's just right for you. The ServSwitch™ family from Black Box—the one-stop answer for all your video and KVM switching and extension needs!

★

This manual will tell you all about your new ServSwitch™ Wizard Skew Compensator, including how to install, configure, and troubleshoot it. For an introduction to the Compensator, see **Chapter 2**. The Compensator product code covered in this manual is:

**ACU5100A**

This manual also includes information about the ServSwitch™ Wizard Extender, Extender Receiver, and Extender Chassis, which have their own manuals or installation guides:

**ACU5010A ACU5011A ACU5000A**

## Contents

<b>Chapter</b>	<b>Page</b>
1. Specifications .....	3
2. Introduction .....	4
2.1 Overview .....	4
2.2 Correcting Color Separation .....	4
2.3 The Complete Package .....	5
2.4 The Compensator Illustrated .....	5
3. Installation .....	6
3.1 What You Will Need .....	6
3.2 Placement .....	6
3.3 The Installation Procedure .....	8
4. Configuration .....	10
4.1 Configuring the Compensator by Eye .....	10
4.2 Configuring the Compensator in a ServSwitch Wizard Extender System .....	13
5. Troubleshooting .....	15
5.1 Calling Black Box .....	15
5.2 Shipping and Packaging .....	15

# 1. Specifications

<b>Cable Required</b> —	Between Skew Compensator and other devices: Four-pair (eight-wire) Category 5 or higher shielded or unshielded twisted-pair (STP or UTP)
<b>Standards</b> —	VGA, SVGA, XGA, or XGA-2 video
<b>Interfaces</b> —	Twisted-pair composite including VGA red, green, and blue on three of the four wire pairs in a cable
<b>Maximum Distance</b> —	Maximum total length of cabling from video source to video destination will vary, depending on the type and construction of the cables, from 100 to 200 m (330 to 655 ft.); two Compensators can be daisy-chained to support total distances up to 300 m (1000 ft.); any patch cables used must be as short as possible
<b>User Controls</b> —	(16) Top-mounted banks of (4) 3-terminal slide switches
<b>Indicators</b> —	None
<b>Connectors</b> —	(2) Right-side-mounted RJ-45 female
<b>Maximum Altitude</b> —	10,000 ft. (3048 m)
<b>Temperature Tolerance</b> —	32 to 104°F (0 to 40°C)
<b>Humidity Tolerance</b> —	5 to 60% noncondensing
<b>Enclosure</b> —	Steel and stainless steel
<b>Power</b> —	Passive, nonpowered
<b>Size</b> —	1"H x 6.5"W x 3.1"D (2.5 x 16.4 x 7.9 cm); Rear edge of endplate protrudes an additional 0.4" (1 cm); optional stick-on feet protrude an additional 0.1" (0.3 cm)
<b>Weight</b> —	15.4 oz. (437 g)

## 2. Introduction

### 2.1 Overview

The ServSwitch™ Wizard Skew Compensator is designed to correct the video-color split or separation that is sometimes introduced when a video picture is transmitted over twisted-pair cables. Twisted-pair cables are typically constructed using four twisted pairs of wires. Each of the wire pairs are normally twisted at slightly different rates to reduce the “crosstalk” interference between the pairs.

This type of construction is highly advantageous for digital data transmission, but can sometimes cause a problem when the cables are used to carry analog video signals. This is because three different wire pairs are typically used to carry the red, green, and blue color components of the video picture. If a cable is long enough and the twist rates of its wire pairs are different enough, there will be a significant difference in the total length of wire that each color signal has to travel. This will cause the color signals to be “skewed” (to arrive at their destination at different times), which will in turn cause the colors to be displayed slightly offset from one another, reducing the picture clarity. (A typical characteristic of this color-split effect is a red, green, or blue shadow around bright white objects.) If you install a Skew Compensator between your video source and destination, it removes this color split by deliberately delaying one or two of the color signals so that all the signals arrive at their destination at the same time.

### 2.2 Correcting Color Separation

Unless you actually install twisted-pair cabling directly between your source and destination and observe the resulting picture, it is remarkably difficult to predict if a Skew Compensator will be needed, because twisted-pair cables from different manufacturers have substantially different characteristics. Although Category 5e and Category 6 cables typically have larger twist-rate differences than Category 5 cables, there are several types of Category 5e and Category 6 cables with low twist-rate differences. Even if you use cables that have similar specifications, the color split introduced by one cable may be four times the color split introduced by another apparently similar cable. (Also keep in mind that color-split effects become more noticeable at higher screen resolutions. This is because the pixel time at higher resolutions is shorter, so a given color delay will affect more pixels.)

As a general rule, color-signal skew is more of a problem with higher-specification cables (such as CAT5e or CAT6), longer cables, and higher screen resolutions. For example, an installation running a screen resolution of 1024 x 768 over 165 ft. (50 m) of CAT5 cable will probably exhibit minimal color separation,

whereas an installation running a screen resolution of 1600 x 1200 over 330 ft. (100 m) of CAT6 cable will probably get a noticeable color split.

If you have a noticeable problem with color separation, you have several choices. You could use a shorter length or different type of twisted-pair cable, or you could reduce the screen resolution that you are using. If none of these solutions are possible, the color split can be corrected by installing the Skew Compensator between the video source and destination.

### 2.3 The Complete Package

The ServSwitch Wizard Skew Compensator (ACU5100A) comes with four adhesive rubber feet, this manual, and one pan-head screw for optionally attaching the Compensator to a ServSwitch Extender Chassis (ACU5000A). If you didn't receive everything, or if anything arrived damaged, contact Black Box right away.

### 2.4 The Compensator Illustrated

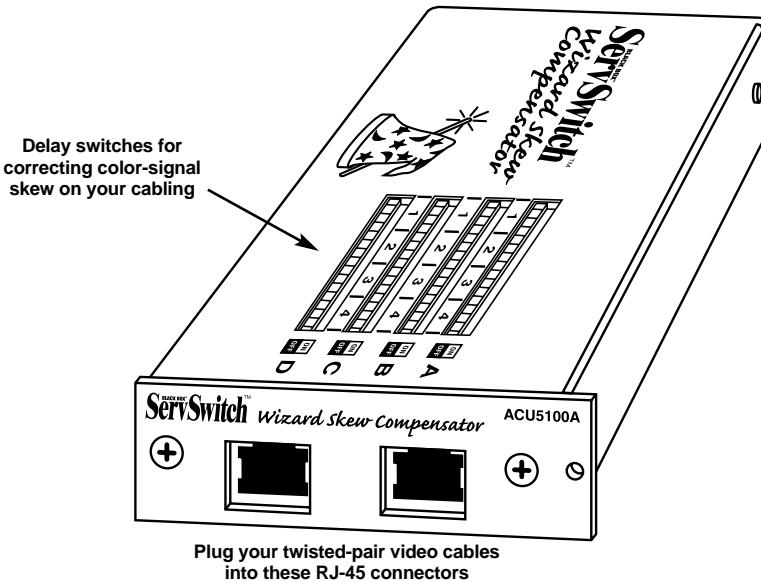

**Figure 2-1. The ServSwitch Wizard Skew Compensator (ACU5100A).**

## 3. Installation

### 3.1 What You Will Need

These things must be in place before you can install your ServSwitch™ Wizard Skew Compensator:

- Four-pair (eight-wire) shielded or unshielded twisted-pair cabling rated to at least Category 5. One cable or set of cabling should be long enough to reach from your video source to your Compensator; the other should be long enough to reach from the Compensator to the video destination. The cabling should include as few patch-panel connections as possible and the least possible length of lower-quality patch cabling.

The maximum total distance that you can run this cabling from the video source to the video destination will vary, depending on the cable's type and construction. Some cable with extreme skew can't be corrected for by a single Compensator over total distances greater than 100 m (330 ft.); average cable can be corrected for over total distances up to 200 m (655 ft.); some very good cable can be corrected for over total distances greater than that. If your cable is good enough, two Compensators can be chained together to compensate for skew over cabling distances up to 300 m (1000 ft.).

- If you'll be mounting the Compensator on a wall or some other non-horizontal flat surface, you'll need adhesive mounting strips—preferably the two-part type made with VELCRO® or other hook-and-loop fasteners, so that after it's mounted you can detach and reattach the Compensator as necessary.

### 3.2 Placement

#### NOTE

If you'd like to put the Compensator in a space in which its rackmount-enabling endplate doesn't fit well, or if you need to remove its endplate for whatever other reason, you can do so by unscrewing the two end-mounted screws that hold it on.

If you want to set the ServSwitch Wizard Skew Compensator on a desktop or some other flat horizontal surface, you'll need to stick the included adhesive rubber feet to the bottom of the Compensator (the wide flat area where there are no connectors and no switches). Four feet are included—attach one in each corner.

To mount a Compensator on a non-horizontal surface such as a wall or the side of a desk, use a pair of double-sided adhesive strips (not included), preferably the

kind that have VELCRO or some other hook-and-loop fastener between the adhesive sides. Peel the backing away from one side of each of the two strips and press the strips firmly onto the bottom of the Compensator. Then peel the backing away from the other side of the strips and press the bottom of the module firmly against the surface you want to mount the Compensator on.

If you're using the ServSwitch Wizard Skew Compensator in a ServSwitch™ Wizard Extender system, the Compensator can be mounted in a ServSwitch Wizard Extender Chassis (ACU5000A), which is designed to be mounted in a standard 19" equipment rack. To mount a Compensator in an Extender Chassis, take these steps, referring to Figure 3-1:

1. Slide the Compensator into the chassis with the protruding tip of its endplate pointing upwards.
2. Screw the included pan-head screw through the hole at the top of the Compensator's endplate and the matching hole in the front flange of the chassis in order to secure the Compensator to the chassis.

To mount the chassis itself, hold its side flanges against the vertical rails of your rack, then use four of your own screws, bolts, cage nuts, etc., to secure the flanges to the rails.

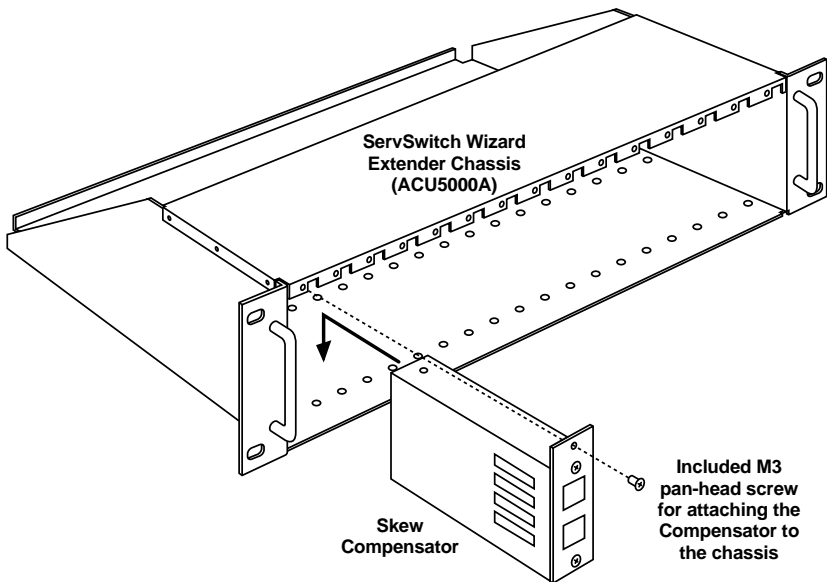

**Figure 3-1. Mounting a Compensator in an Extender Chassis (ACU5000A).**



### 3.3 The Installation Procedure

First make sure the video-source and video-destination devices are turned off and unplugged. Then take these steps to install the Skew Compensator, keeping in mind that all of its switches should be set to OFF and that the total cable length between the video source and destination must not be more than the Compensator can support (see the cable discussion in **Section 3.1**):

1. Run CAT5 or higher twisted-pair cable (not included) between your video source and the Compensator. Attach this cable to either of the two RJ-45 connectors on the Compensator's right side. If this is a lower-quality patch cable, it should be as short as possible.
2. Run CAT5 or higher twisted-pair cable (not included) between the Compensator's other RJ-45 connector and your video destination. If this is a lower-quality patch cable, it should be as short as possible.
3. Plug in and power up the video-source and video-destination devices. For now, the video signal will pass transparently through the Skew Compensator; the Compensator will have no effect on the color signals until its delay switches are set to different values than their factory defaults.

That's all there is to it. A sample installation is shown in Figure 3-2. Configure the Compensator as described in **Chapter 4** to correct the color skew in your system.

#### **NOTE**

It's possible to daisychain a pair of Compensators in order to compensate for extremely skewed cable or for longer distances of average or good cable, up to a maximum of 300 m (1000 ft.) if the cable quality is high enough. To install two Compensators, simply run one cable from the video source to the first Compensator, another cable from the first to second Compensator, and a third cable from the second Compensator to the video destination.

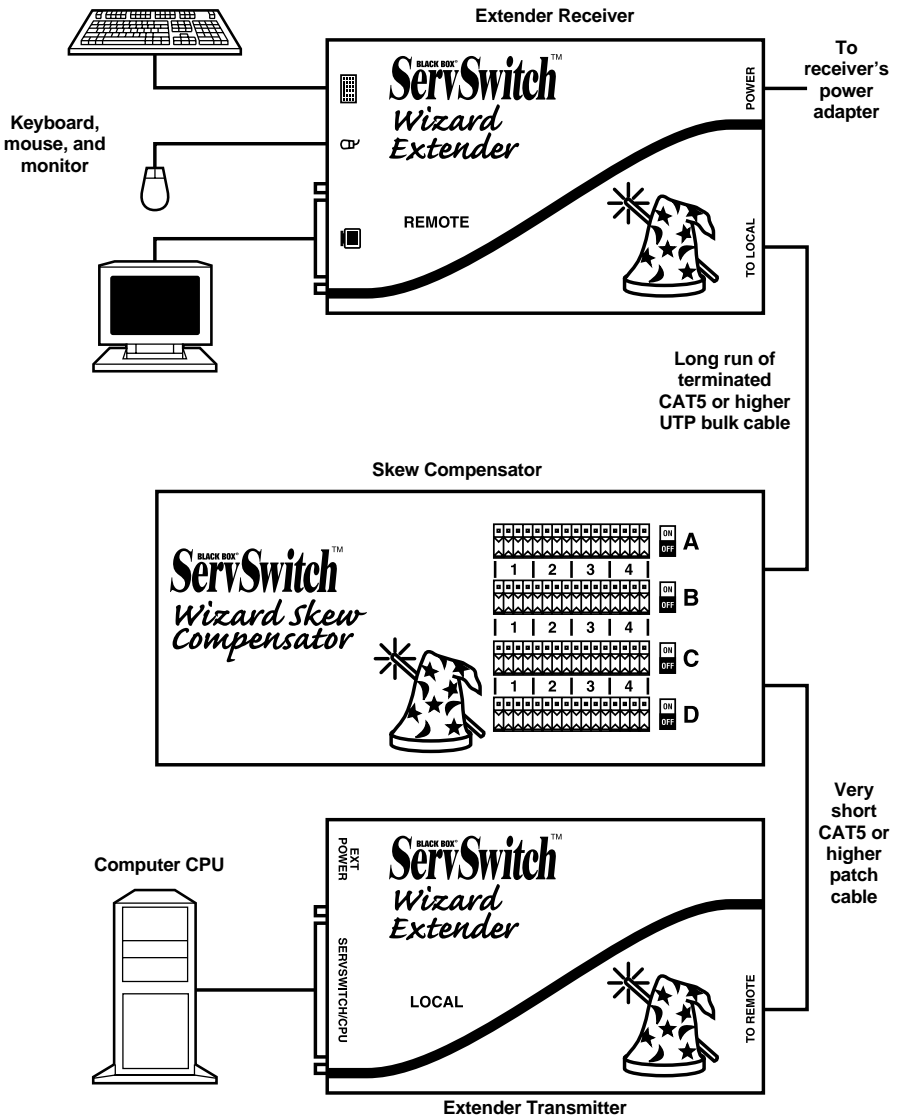

Figure 3-2. A ServSwitch Wizard Extender (ACU5010A) system with a Skew Compensator installed.

## 4. Configuration

To configure your ServSwitch™ Wizard Skew Compensator, you'll set the sixteen banks of slide switches on its top panel. In applications that don't involve the ServSwitch Wizard Extender (ACU5010A or ACU5011A), you'll do this by making adjustments "by eye," looking at the video image to decide how to set the switches (which is not as difficult as it might sound). This approach is discussed in **Section 4.1**. If you use the Compensator with the ServSwitch Wizard Extender, you can get a "skew report" from the Extender that will include recommended Compensator settings. **Section 4.2** discusses how to get this report and how to set the Compensator accordingly. (Even in this situation, setting the Compensator by eye will probably prove more accurate.)

### 4.1 Configuring the Compensator by Eye

Unless you're using the ServSwitch Wizard Extender, you'll have to judge which of the Compensator's slide switches to set by looking at the video image. First, figure out which banks of switches control which color:

- Banks A1 through A4 control the delay of any color on Pair 2 (wires 1 & 2).
- Banks B1 through B4 control the delay of any color on Pair 3 (wires 3 & 6).
- Banks C1 through C4 control the delay of any color on Pair 1 (wires 4 & 5).
- Banks D1 through D4 control the delay of any color on Pair 4 (wires 7 & 8).

In the pinout used by compatible products such as the ServSwitch™ Duo and ServSwitch™ Quadro, the A banks control blue, the B banks control red, and the C banks control green; other products might have different color correspondences.

With the Compensator installed and with all of its switches set to OFF, examine the image on your screen at the destination end. If possible, send a steady test-pattern video image through the link that consists of a bright white object against a black background. (If the video-source device is a computer, such an image would be easy to create with most desktop-publishing, Web-content, or art programs.) If you notice that one or more of the primary colors (red, green, or blue) in the video image displayed on your monitor has separated from the others and is horizontally offset from them on your screen—for example, if colored shadows trail the white object, as shown in Figure 4-1—that's the result of your existing color skew.

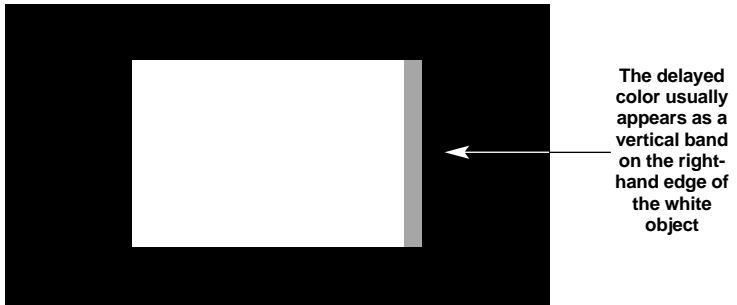

**Figure 4-1. Skew at its most visible (color trailing a white object against a dark background).**

Now choose one set of four banks that control a single wire pair (for example, A1 through A4). Set all of the switches in those banks to ON and see what happens. Perhaps the existing skew will get much worse, or one of the other colors will now be skewed. Or perhaps nothing will happen; if so, that wire pair carries a non-video signal. Record which color (if any) is affected by each bank, then move on to the next one. (For example, if red shadows become prominent when all of A's switches are ON, write down "A = red," move the A switches back to OFF, and move all of the B switches to ON.)

When you know which banks go with which colors, move all of the Compensator's switches back to OFF and return the system to the skew that it started with. Look at your video image again and try to see which of the colors is most delayed—that is, which one makes shadows (or the most pronounced shadows) after white objects. Leave the switches that control this color set to OFF and start to add delay to the other colors by setting some of their associated switches ON.

Start with the "1" bank for one of the less-skewed colors, moving *all four* of its switches to ON. This will add 10 nanoseconds (10 ns) of delay to that color signal. Is the delay of that color now less than, equal to, or greater than that of the most-delayed color?

- If the delay is equal (the shadows of the two colors line up), move on to the third color.
- If the delay is less (the shadow of the most-delayed color is still more pronounced than that of the second color), add more delay to the second color by moving some combination of the remaining switches ON. The "2" bank adds another 10 ns (twice as much delay), the "3" bank adds 5 ns (half again as much delay), and the "4" bank adds 2.5 ns (a quarter again as

much delay). You must move *all four* switches in a bank to ON for the delay to take effect.

- If the delay is greater (the shadow of the second color is now more pronounced than that of the previously most-delayed color), move the “1” switches back to OFF and move some combination of the “3” and “4” switches to ON. The “3” bank adds 5 ns (half again as much delay), and the “4” bank adds 2.5 ns (a quarter again as much delay).

*Example #1:* If red is the most-delayed color in your system, green has no noticeable delay, and green is controlled by the C banks, move the four C1 switches to ON to add 10 nanoseconds to green. If only two-thirds of the shadow becomes yellow (optically, red + green = yellow), leave the four C1 switches ON and also move the four C3 switches to ON to add another 5 ns to green. The shadow should now be almost perfectly yellow with no red or green trailing fringe.

*Example #2:* If red is the most-delayed color in your system, blue has half as much delay so that the leading half of the shadow is magenta (reddish purple), and blue is controlled by the B banks, move the four B1 switches to ON to add 10 nanoseconds to blue. If the existing shadow becomes all magenta trailed by a blue shadow half again as long, move the B1 switches back to OFF and move the four B3 switches to ON to cut the blue delay back to 5 ns. The shadow should now be almost perfectly magenta with no red or blue trailing fringe.

*Example #3:* If green is the most-delayed color in your system, blue has no noticeable delay, and blue is controlled by the A banks, move the four A1 switches to ON to add 10 nanoseconds to blue. If the skew is extreme and less than half of the existing shadow becomes cyan (blue-green), leave the four A1 switches ON and also move the four A2 switches to ON to add another 10 ns to blue. If the shadow still has a trailing green edge, leave the A1 and A2 switches ON and also move the four A3 switches and/or the four A4 switches to ON to add 5 and/or 2.5 more nanoseconds to blue. One of these combinations should yield a shadow that's almost perfectly cyan with no green or blue trailing fringe.

After this step, the white object in the on-screen test pattern will now have a trailing cyan, magenta, or yellow shadow, and there will also be a leading shadow of the third primary color (the one that hasn't yet been adjusted). Move on to the switch bank that controls the third color and repeat the visual-adjustment process for that color until the trailing shadow becomes entirely white and disappears, leaving only the crisp white object on screen with very little or no color separation.

At this point the Skew Compensator has been fully configured and can be left in place to provide continuous skew compensation for your system.

## 4.2 Configuring the Compensator in a ServSwitch Wizard Extender System

If you've installed the Skew Compensator in a ServSwitch Wizard Extender system, the Extender can provide a "skew report" that includes recommended configuration settings for the Compensator. (These settings should be fairly close to correct, although you might want to fine-tune them using the procedure in **Section 4.1**.) To get this skew report, take these steps:

1. Make sure that the Compensator's slide switches are set to OFF, and that the Extender's transmitter and receiver are connected to the Compensator with the twisted-pair cable you want to use.
2. If you're using a manual setting for your Extender system's overall video compensation (not the same as skew compensation; see the "Configuring the Extender" section in your Extender manual), make sure that the Extender's video compensation is at its best. (If the picture is not correctly compensated overall, the skew report might be less accurate.)
3. At the computer attached to the Extender's transmitter, bring up a DOS command prompt, a text prompt in a word-processing program, or a similar point in some other application that can display several lines of typed characters at once on the screen of the monitor attached to the Extender's receiver. (The Extender generates the skew report by sending keypress signals to the computer, as if the report had been typed in at the keyboard attached to the receiver.)
4. Go into configuration mode by pressing the Extender's hotkeys followed by [Enter] at the keyboard. (The default hotkeys are [Ctrl] + [Shift].)
5. If you have an English, German, etc. QWERTY keyboard, press the letter [F] followed by the number [3]. If you have a French AZERTY keyboard, press the letter [F] followed by the number [4]. The skew report will appear, as described on the next page.
6. Press [Enter] to exit configuration mode.

When you press [F][3] or [F][4], the monitor screen should go blank for a few seconds as the Extender applies measurement signals to the cable to measure the differences between the twisted pairs. When the picture is restored, a report similar to this one should appear:

### SKEW REPORT

RED +0.5M  
GREEN +1.0M  
BLUE +0.0M

SWITCHES ON  
A3 B4

The first section of the report indicates the length differences between the twisted pairs that are carrying the red, green, and blue color signals. One of the colors will have a reported length difference of "+0.0M"; this is the color carried by the *shortest* twisted pair. The other reported differences are how much *longer* the other pairs are than the shortest one.

The second section of the report indicates which of the Skew Compensator's top-panel switches should be set to ON to compensate for the twisted-pair length differences indicated by the report. All other switches should be OFF. The example skew report above indicates that all of the switches in switch banks A3 and B4 should be ON and all the other switches should be OFF.

If you set the Skew Compensator's switches as indicated in the report, you should get adequate skew compensation.

### NOTE

Because the cabling between the CPU and the Extender's transmitter can itself introduce some signal skew, sometimes setting the Skew Compensator by eye as described in Section 4.1 produces better results than relying on the skew report.

### TECHNICAL NOTE

Each meter of the length differences between the pairs that the Extender reports is equivalent to 5 nanoseconds of delay. For comparison, you can get a rough estimate of your system's on-screen "pixel time" by multiplying the horizontal pixels by the vertical pixels by the refresh rate and then dividing 1 by the result. If the delay time is greater than the pixel time, color split will be noticeable.

For example, if the maximum reported difference is 1.5 meters, the delay between color signals will be  $1.5 \times 5 \text{ ns} = 7.5 \text{ ns}$ . If the screen resolution being used is 1024 x 768 x 75 Hz, the pixel time is roughly  $1 / (1024 \times 768 \times 75) = 16.9 \text{ ns}$ . Consequently, the color split will be less than half a pixel time and so is unlikely to be noticeable.

# 5. Troubleshooting

## 5.1 Calling Black Box

If you determine that your ServSwitch™ Wizard Skew Compensator is malfunctioning, *do not attempt to alter or repair the unit*. It contains no user-serviceable parts. Contact Black Box Technical Support at 724-746-5500.

Before you do, make a record of the history of the problem. We will be able to provide more efficient and accurate assistance if you have a complete description, including:

- the nature and duration of the problem;
- when the problem occurs;
- the components involved in the problem—that is, what type of cable, what type of video-source and video-destination devices, what make and model of monitor, etc.;
- any particular application that, when used, appears to create the problem or make it worse; and
- the results of any testing you've already done.

## 5.2 Shipping and Packaging

If you need to transport or ship your Compensator:

- Package it carefully. We recommend that you use the original container.
- Before you ship it back to Black Box for repair or return, contact us to get a Return Authorization (RA) number.



## TRADEMARKS USED IN THIS MANUAL

BLACK BOX and the  logo are registered trademarks, and ServSwitch, ServSwitch Duo, ServSwitch Quadro, and ServSwitch Wizard are trademarks, of Black Box Corporation.

Apple and Macintosh are registered trademarks of Apple Computer, Inc.

IBM and RS/6000 are registered trademarks of International Business Machines Corporation.

Sun and Sun Microsystems are registered trademarks of Sun Microsystems, Inc. in the United States and other countries.

*Any other trademarks mentioned in this manual are acknowledged to be the property of the trademark owners.*

## DISCLAIMERS

While every precaution has been taken in the preparation of this manual, the manufacturer assumes no responsibility for errors or omissions. Neither does the manufacturer assume any liability for damages resulting from the use of the information contained herein. The manufacturer reserves the right to change the specifications, functions, or circuitry of the product without notice.

The manufacturer cannot accept liability for damage due to misuse of the product or due to other circumstances outside the manufacturer's control. And the manufacturer will not be responsible for any loss, damage, or injury arising directly or indirectly from the use of this product.

## NOTES

## NOTES



**Customer Support Information:**

FREE tech support 24 hours a day, 7 days a week: Call **724-746-5500** or fax **724-746-0746**.

Mailing address: **Black Box Corporation**, 1000 Park Dr., Lawrence, PA 15055-1018

World-Wide Web: [www.blackbox.com](http://www.blackbox.com) • E-mail: [info@blackbox.com](mailto:info@blackbox.com)

© Copyright 2001. Black Box Corporation. All rights reserved.